

Cc:

Subject:Your article proofs for review (Manuscript ID: OAEF 1488343)

Manuscript Title: OAEF_A_1488343

Manuscript DOI: 10.1080/23322039.2018.1488343

Journal: Cogent Economics & Finance

Dear Ansari Saleh Ahmar,

I am pleased to inform you that your proofs are now available for review using the Cogent OA online proofing system:

<https://www.icorrectproof.com/Home/Integra?bpH59qSn1W/hy66RE4YUuboEBPar714ZGhIsmqhXLZULzA+IzvRUsj72yHese15W/3CljXCq3MPjiiMivC7s3X4dmz4vowZRSAKnfgFxGdijSAetfUQGcw==>

Log-in email address: ansarisaleh@unm.ac.id

Please submit your corrections by 28 June 2018, to avoid delay to publication.

Please ensure that you answer all Author Queries. Typographical and essential corrections can also be made at this point.

Your article should be published online within 5–7 working days of us receiving your corrections, as long as you have returned your Author Publishing Agreement.

The DOI of your article is: 10.1080/23322039.2018.1488343. and your article will be available at the following permanent link as soon as it has published online: <http://dx.doi.org/10.1080/23322039.2018.1488343>.

If you have any questions, please contact me using the details below and I will be pleased to assist.

Thank you,

Balaji Shanmugam

On behalf of the OAEF production team

Cogent OA

2-4 Park Square, Milton Park, Abingdon, Oxfordshire, OX14 4RN, United Kingdom

Email: OAEF-production@journals.tandf.co.uk

This email and any accompanying attachments is for the sole use of the intended recipient(s) and may contain confidential and privileged information. Any unauthorized review, use, disclosure, distribution, or copying is strictly prohibited. If you are not the intended recipient of this communication or received the email by mistake, please notify the sender and destroy all copies. Integra Software Services Pvt Ltd. reserves the right, subject to applicable local law, to monitor and review the content of any electronic message or information sent to or from its company allotted employee email address/ID without informing the sender or recipient of the message.



Attachment download links.html

4K

OAEF 1488343 - Proof corrections required #TrackingId:1346440

OAEF-production@journals.tandf.co.uk <OAEF-production@journals.tandf.co.uk>

Wed, Jul 11, 2018 at 1:59 PM

To: ansarisaleh@unm.ac.id

Cc: wahyuddin@unimal.ac.id, arifai_m@yahoo.co.uk, fauzias@usim.edu.my, darmawati@unimal.ac.id

Dear Ansari Saleh Ahmar,

I hope you are well.

I am writing because we have not yet received the proof corrections for your paper entitled 'Dynamic Performance of Indonesian Public Companies: An Analysis of Financial Decision Behavior', which were due to be returned to us by 28th June.

I have attached the typeset PDF proof of your article to this email for your convenience. Please can you answer the Author Queries (AQs) raised by our copy-editing team, and also let us know of any additional amendments or corrections that you want to make.

Please then return the file directly to me and I will pass it on to the typesetter. You can mark up the attached PDF, or list your corrections in a Word document, or email.

Please can you return your corrections to me by tomorrow (Thursday 12th July).

I'm copying in your co-authors in case you are unavailable at present.

If you have any further queries, please just let me know.

Best wishes,

Balaji

Cogent OA, Taylor & Francis Group
2&4 Park Square, Milton Park, Abingdon
Oxfordshire, OX14 4RN
UNITED KINGDOM
www.CogentOA.com

To successfully download attachments you may need to switch off any pop up blockers that your web browser is running. Your browser may present you with the option to 'allow once', or you can find the option to permanently switch off pop up blockers under your browser's Settings menu. Attachments may not open up straight away when you click on the link as they are first being downloaded from the cloud. Please check for a downloaded document icon at the bottom of your screen (in Chrome, IE or Firefox) or in your downloads folder in Safari.

Cogent Economics

From: cogentoa.iproof@integra.co.in

Sent: 26-06-2018 07:41

To: cogentoa.iproof@integra.co.in, ansarisaleh@unm.ac.id

Cogent Economics and Finance

Dynamic Performance of Indonesian Public Companies: An Analysis of Financial Decision Behavior --Manuscript Draft--

Full Title:	Dynamic Performance of Indonesian Public Companies: An Analysis of Financial Decision Behavior
Manuscript Number:	COGENTECON-2018-0039
Article Type:	Research Article
Section/Category:	Financial Economics
Keywords:	Financial decision; Dynamic performance; GMM-Difference
Manuscript Classifications:	10.6.2.3 Financial Mathematics; 50.6.3.2 Corporate Finance; 50.6.3.5 Investment & Securities
Abstract:	<p>The purpose of this research is to investigate the effects of financial decision behavior on firm performance of Indonesian public companies using panel data. The dynamic generalized method of moment (GMM) is utilized in this study. The results show that firm performance are dynamic in nature, indicates that last year performance affects current performance significantly. Empirical result of financial decision behavior shows that investment, leverage and dividend per share have significant impact on firm performance (ROA and Tobin's Q ratio). This indicates that investment and leverage has negative effects on ROA, but leverage is positive effect on Tobin's Q. Moreover, dividend per share (DPS) has positively affects ROA as well as Tobin's Q. This finding suggests investment decision of Indonesian public companies is overinvestment, which is show with higher investment affects firm performance negatively. Regarding to financing decision, firm leverage also negative effect on firm performance, mean that Indonesian public companies borrowed external fund more than they need (over-leverage). However, dividend policy indicate that the higher firm performance encourage firms to payout dividends to its shareholders. The positive relation between dividend per share and Tobin's Q implies that firm payout dividends to shareholders create good signal to the market, which is manager's uses dividend to express their private information about firm prospect of the future earning to the market.</p>

Dynamic Performance of Indonesian Public Companies: An Analysis of Financial Decision Behavior

Darmawati Muchtar¹, Fauzias Mat Nor², Wahyuddin Albra¹,
Muhammad Arifai³, and Ansari Saleh Ahmar⁴

¹Faculty of Economy and Business, Malikussaleh University, Lhokseumawe, Aceh, Indonesia, darmawati@unimal.ac.id

²Faculty of Economy and Muamalat, Islamic Science University of Malaysia, Nilai, Malaysia, fauzias@usim.edu.my

³Department of Accountin, Lhokseumawe State of Polytechnic, Aceh, Indonesia, arifai_m@yahoo.co.uk

⁴Department of Statistics, Universitas Negeri Makassar, Makassar, Indonesia, ansarisaleh@unm.ac.id

Abstract

The purpose of this research is to investigate the effects of financial decision behavior on firm performance of Indonesian public companies using panel data. The dynamic generalized method of moment (GMM) is utilized in this study. The results show that firm performance are dynamic in nature, indicates that last year performance affects current performance significantly. Empirical result of financial decision behavior shows that investment, leverage and dividend per share have significant impact on firm performance (ROA and Tobin's Q ratio). This indicates that investment and leverage has negative effects on ROA, but leverage is positive effect on Tobin's Q. Moreover, dividend per share (DPS) has positively affects ROA as well as Tobin's Q. This finding suggests investment decision of Indonesian public companies is overinvestment, which is show with higher investment affects firm performance negatively. Regarding to financing decision, firm leverage also negative effect on firm performance, mean that Indonesian public companies borrowed external fund more than they need (over-leverage). However, dividend policy indicate that the higher firm performance encourage firms to payout dividends to its shareholders. The positive relation between dividend per share and Tobin's Q implies that firm payout dividends to shareholders create good signal to the market, which is manager's uses dividend to express their private information about firm prospect of the future earning to the market.

Keyword: Financial decision, Dynamic performance, GMM-Difference.

1. INTRODUCTION

This study deals with an important issue in corporate finance, in which we investigate the dynamic firm performance and financial decision behavior. Even though most of prior studies of firm performance and financial decision have been done, but still interesting to be analyzed and discussed, because in fact that a firm periodically makes three major important financial policies that determine its structure. Firm performance is associated with the concepts of productivity, efficiency and effectiveness of corporate management in utilizing resources optimally (Tan & Wang 2010). The Indonesia firms performance recorded the average ROA was valued at 12.69 while Tobin's Q at 2.10 percent, indicates Indonesia firms had good market performance although they suffered with low profitability (Bambang Sudiyatno et al. 2012). Moreover, the market performance was lower with the average 1.13 percent for period 2009 to 2013 (Nikolaus 2015), this implies market performance still in good health, and that the financial decision play an important role to enhance firm performance. In this issue, the task of managers is taking right decision on investment decision, financial leverage and dividend policy (Inselbag 1973).

The value of firm is determined by investment decision (Fama 1978), although in perfect capital market investment decision is independent of the financial structure. This is because external funds serve as a perfect replacement for internal capital (Modigliani & Miller 1958). In contrast, empirical research shows that internal and external capitals do not perfectly substitute each other in the short-run, meaning that investment should be dependent on financial factors, so that both investment and financing decisions are interdependent in imperfect capital market, and the debt financing influences value of the firms (Modigliani & Miller 1963).

Additionally, several earlier studies on investment decisions have been widely discussed in relation of the cash flow and investment level to analyse the problems of over and under-investment (Fazzari. et al. 1988; Hubbard 1998; Kaplan & Zingales 1997), the over-investment occurs when firms have excess internal funds (Jensen 1986), the issue arise for Indonesian listed firm, which is investment has negative effect on firm performance but insignificant (Bambang Sudiyatno et al. 2012). Another issue is the global financial crisis impacted the economic and manufacturing firms turn to lower investment and capital market confidence plunged significantly (Djaja 2009).

Regarding financing decision, the issues occur when companies assess their financial needs, their borrowing capacity and their ability to generate shareholder returns and maximize the firm value. Therefore, financing decision and policy to raise financial resources are among very important considerations. The consequence of higher leverage, firm may suffer agency cost and bankruptcy. Therefore, financial leverage and firm performance has negative relationship (Jensen & Meckling 1976; Myers 1977). However, some researchers dispute that financial leverage and firm performance has positive relation because debt financing implies a commitment on managers to payout more cash, and may discipline managers by restricting the amount of free cash flow under their control (Jensen 1986). However, the level of leverage is higher for Indonesia firms, in which the debt to equity ratio (DER) was 56 percent by sector (Hardiyanto et al. 2014).

Lastly, dividend policy issue of firm performance, in which dividend itself having implicit private information and is a signaling device to influence stock price (Bhattacharya 1979; John & Williams 1985; Miller & Rock 1985). Thus, when a firm announces an increasing dividend, it is a sign of good news in the capital market with positive reaction of share price. Therefore, only good performance firms can send signals to the market using dividends. However, dividend policy appears to have a matter in firm behavior, in this case, the issue of why the firm should pay dividends or hold dividend payout is still unresolved. This is due to the fact that many listed companies in Indonesia do not pay dividends regularly. One explanation is that the firm is deferring dividend payments because the firm needs more funds to finance its investment specifically during the financial crisis. In Indonesia, the propensity of the firm pay dividend has decline over time and dividend life-cycle explains well the dividend policy (Leo Indra Wardhana et al. 2014). Therefore, this study proposes to investigate the impact of investment, leverage and dividend per share on firm performance. Investment in stock market have been studied by Ahmar, Rahman, Arifin, & Ahmar (2017) and

This study apply the dynamic panel Generalized Method of Moment (GMM) estimator to respond the endogeneity issue in corporate finance behavior, which is the dynamic panel GMM estimator more advanced estimators rather than the static model estimation (OLS, fixed effect and random effect model) provide biased estimates, due to the presence of the lagged dependent variable, and it can be used to control for the dynamic nature of relationship between firm performance and financial decision behavior while accounting for other sources of endogeneity in corporate finance research (Wintoki et al. 2012). Therefore, to providing additional evidence on the impact of financial decision on firm performance, the present study contributes to the existing literature by providing economic justification for use of dynamic panel GMM estimation for both accounting and market performance. The rest of this paper is organized as follows. In

section 2 reviews the literature and hypotheses are developed. Section 3 and 4 describes the methodology and empirical results, respectively whereas section 5 concludes.

2. LITERATURE REVIEW

2.1 Investment and Firm Performance

The relationship between investment and firm performance has been examined by several prominent researchers from underpinning theories of investment (Fama 1978; Modigliani & Miller 1958; Tobin 1969). The Tobin's q become a central theoretical model of investment and provides an empirical framework for analyzing individual firm's financial decisions. It is also a popular proxy for the unobservable investment opportunities based on market value. According to Fama and Miller (1972) proposed that the market value of a firm is the discounted value of expected future cash flows from all its investment in the present and future; i.e., an increase in capital expenditure will have a positive impact on a firm's market performance. For instant some studies found a positive relationship between firm performance and investment (Grazzi et al. 2011; Riachi & Schwiendbacher 2015). However, others studies indicated a significant and negative relationship between investment and firm performance (Bambang Sudiyatno & Elen Puspitasari 2010). Similarly, studies by Ruzita et al. (2010) found that investment has insignificant impact on firm performance. Although there is a limited number of a study in the relationship between firm performance and investment, there is some literature on such relationship on other factors (Loof & Heshmati 2008). Then, Del Brio et al. (2003), examined the relationship between investment and firm value using panel data, the interestingly, results show that the positive or negative market reactions to investment (divestment) announcement persist over time. This implies that the increase in firm value is greater for the firm with valuable investment opportunities and when firms divesting is a sign of decrease in value for the firms with valuable investment opportunities.

2.2 Leverage and Firm Performance

A number of researchers conducted empirical work to show the changes in level of debt that have impact on the total market value of the firm. So that, the firm value reflects a valuation by shareholders, including the value perquisites consumed by manager as the agent of shareholders (Jensen & Meckling 1976). However, the trade-off theory stated that when the firm has a higher profitability rate, the expected cost of distress would decrease, and the firms will prefer to use debt financing because of their raised leverage, even if it increases the risk of bankruptcy and financial distress (Scott 1977). The pecking order theory explained the firms are more likely to use the internal funds and prefer debt to equity when external financing is needed, then therefore, the pecking order theory concluded that issuing debt is not for companies with more funds and liquid (Myers & Majluf 1984). The relationship between capital structure and firm performance has been investigated by many researchers with mixed results. For instance, some studies found a positive relationship between financial leverage and firm performance (Abu-Rub 2012; Bassey & Inah 2012; San & Heng 2011; Zeitun & G.Tian 2007). However, other studies indicated a significant and negative relationship between firm performance and financial leverage (Onaolapo & Kajola 2010; Saeedi & Mahmoodi 2011; Vithessonthi & Tongurai 2015; Zeitun & Saleh 2015). Others recent evidence examined by Olokoyo (2013) found that TDTA significantly has positive and significant effect on Tobin's Q , but ROA is negative significant. Shahzad et al. (2015), examined the impact of financial leverage on firm performance and found that leverage has negative and significant effect on ROA, whereas SDTA has positive effect on Tobin's Q .

2.3 Dividend Policy and Firm Performance

The relationship between dividend policy and firm performance has received a lot of attention in past studies. Various theories have been proposed by academicians on the principles of dividend policies that have been described as either irrelevant or relevant theory in making financial decision (Deangelo et al. 2006; Miller & Modigliani 1961; Stulz 2000). Miller and Modigliani (1961) stated that dividend policy is irrelevant for the cost of capital, and that the value of the firm is determined by its earning power and risk. The agency theory explained about dividend payment increases firm value (Easterbrook 1984), He argued that dividend payments may act as one form of bonding cost. The transaction cost theory implies that dividend payment reduces in value because they lead to rising external financial costs. Moreover, firms with insufficient cash flow have greater dependency on external finance, and should maximize shareholders wealth by accepting lower payout policies (Rozeff 1982). The empirical evidence proposed that firms with a higher free cash flow should pay more dividends to decrease agency cost (Holder et al. 1998; Mollah et al. 2002). In addition, relating to dividend payment the firms paying dividend are significantly having greater cash flows (Berk 2006). The relationship between dividend policy and firm performance have been addressed (Amidu 2007; Charles et al. 2014; Murekefu & Ouma 2012; Uwuigbe et al. 2012) found that dividend policy has positive relation on firm performance. Moreover, Velnampy et al. (2014) show the opposite results with others, in which dividend payout and firm performance has negative and significant relationship.

3. METHODOLOGY

To investigate the impact of financial decision behavior on firm performance, this study uses yearly of 212 non-financial listed firms for the period from 2003 to 2013. The data are gathered from the annual report of companies includes book value of total assets and total debt, net income, market value of equity, dividend per share and others financial data uses in this study also corporate board structure. The data are retrieved from the latest version 2.1 of Datastream and annual report of companies. Therefore, this study has annual observation of over than 11 years period per company, producing a balanced panel data of 2332 unit observations for data analysis.

This study used numerical variables to measures dependent and independent variables. Firm performance defined as a bivariate dependent variable by two measurements, namely accounting-base performance and market-based performance (ROA and TOBINS_Q). ROA is defined as the ratio of net profit divided by total assets. TOBINS_Q is the ratio of market value of equity plus book value of the total debt divided by the book value of total assets each firm and years (Fauzias et al. 2011; Velnampy et al. 2014; Zeitun & Saleh 2015). The independent variables of financial decision behavior are investment, capital structure and dividend policy. Investment is presented as the exponential growth rate of total asset of the firm i , at the time t , calculated as log natural of total asset at the time/year t divided by total assets at previous year ($t-1$) (Norazlan Alias et al. ; Ruzita et al. 2010). Capital structure is a combination of debt and equity and the level of it debt is referred to as leverage ratio. This study defined leverage as the ratio of total debt to total asset (Saeedi & Mahmoodi 2011; Zeitun & Saleh 2015). Meanwhile, the dividend per share (DPS) was used to measure dividend policy in this study. Dividend per share is the total amount of dividends paid to the total of share outstanding (Charles et al. 2014; Velnampy et al. 2014).

Furthermore, the free cash flow (FCF), board size (B_SIZE), board independent commissioners (B_ICOM) and sales are uses as control variables. The FCF is the ratio of the total of (EBIT and depreciation) mines the total of (interest, tax and dividend) divided by book value of total asset (Norazlan Alias et al. ; Ruzita et al. 2010; Wang 2010). Corporate governance

measured by board size and board of commissioners independent. Board size (B_SIZE) is total number of directors have been employed by (Guo & Kga 2012; Shahzad et al. 2015; Wintoki et al. 2012; Zeitun 2014) and BOC Independent (B_ICOM) is measured by calculating the proportion of independent commissioners with respect to the total commissaries as measured by (Magdalena 2012; Romlah Jaffar et al. 2013; Zabri et al. 2016). Meanwhile, firm size is the natural logarithms of the total sales (Margaritis & Psillaki 2010; Norazlan Alias et al. 2016; Wang 2010).

In order to discover relationship between independent and dependent variable, the dynamic GMM estimator is utilized in this study. The first lagged of firm performance are likely to be endogenous or highly correlated with the dependent variables, so that they are correlated with the error term. Therefore, the OLS or static model estimation method would not be an appropriate method or would be bias for estimating the model parameters. Following the extension of the panel data analysis presented by Baltagi (2008), the multiple regression model applied in this study is the p -th order lagged variable model with the following general equation;

$$Y_{it} = \beta_0 + \sum_{j=1}^p \beta_j \times Y_{i,t-j} + \sum_{k=1}^K \delta_k \times X_{k,it} + u_{it} \quad (1)$$

where the dependent variable is each of the variables firm performance (ROA and TOBINS_Q), and the independent variables are all defined determinant variables. So we have the following two general equations, for $t > p$, where the integer p will be selected so that the lagged variables models fit the data. The empirical equation as follows:

$$ROA_{it} = \beta_0 + \beta_1 ROA(-1) + \dots + \beta_p ROA(-p) + \delta_1 INV_{it} + \delta_2 LEV_{it} + \delta_3 DPS_{it} + \delta_4 FCF_{it} + \delta_5 B_SIZE_{it} + \delta_6 B_ICOM_{it} + \delta_6 F_SIZE + \varepsilon_{it} \quad (2)$$

$$TOBINS_Q_{it} = \beta_0 + \beta_1 TOBINS_Q(-1) + \dots + \beta_p TOBINS_Q(-p) + \delta_1 INV_{it} + \delta_2 LEV_{it} + \delta_3 DPS_{it} + \delta_4 FCF_{it} + \delta_5 B_SIZE_{it} + \delta_6 B_ICOM_{it} + \delta_6 F_SIZE_{it} + \varepsilon_{it} \quad (3)$$

Furthermore, note that the regression of dynamic panel model in equation (2 and 3) in fact is an additive model of Y , and a single numerical determinant, such as $Y(-1)$ INV, LEV, DPS and FCF, B_SIZE, B_ICOM, F_SIZE as control variables.

4. DISCUSSION OF RESULTS

The summary of descriptive statistical analysis of the variables used in this research is based on the final sample of 212 companies. The descriptive indicators' result is presented in Table 5.1, the results shows that the mean of firm performance for both ROA and TOBINS_Q are 3.8 percent and 101 percent respectively. TOBINS_Q has greater standard deviation of 62.7 percent compared to ROA with a standard deviation of 12.7 percent. This value indicates that the data of return on assets (ROA) has the lowest fluctuation for each company compared to others. TOBINS_Q has the highest fluctuation compared to financial decision variables. On average, the investment is about 9 percent with standard deviation is 23.59 percent. Leverage has average is about 27.52 percent with standard deviation 20.79 percent and dividend per share (DPS) has average about 968 rupiah and with standard deviation 3.254.

Table 1 Descriptive statistic of the numerical research variables

	Mean	Median	Maximum	Minimum	Std. Dev.	Observation
ROA	0.0379	0.0313	0.9917	-0.9866	0.1270	2332
TOBIN_Q	1.0147	0.8275	3.2280	0.1012	0.6268	2332
INV	0.0893	0.0817	1.3715	-2.0067	0.2359	2332
LEV	0.2752	0.2438	0.9867	0.0002	0.2079	2332
DPS	0.0968	0.0000	5.6823	0.0000	0.3254	2332
FCF	0.0712	0.0650	1.9703	-1.7842	0.1823	2332
B_SIZE	4.3568	4.0000	13.0000	1.0000	1.8716	2332
B_ICOM	0.3027	0.3300	0.5000	0.2000	0.6722	2332
F_SIZE	20.6137	20.7748	25.9905	0.0000	2.3516	2332

Table 2 present the correlation between firm performance (ROA and TOBINS_Q) and the financial decision (INV, LEV and DPS) and other variables (B_SIZE, B_ICOM and F_SIZE). In Table 5.2 shows that accounting performance reported to be positive correlation with the investment, dividend per share, free cash flow, board size and firm size but negatively correlated with leverage. Moreover, TOBINS_Q are reported to be positive correlated with dividend per share, free cash flow, board size and firm size but investment, leverage and independent commissioner's shows insignificant correlation.

Table 2: The correlation signs of independent variables with firm performance

Independent Variables	ROA	TOBINS_Q
INV	+	+/ins
LEV	-	+/ins
DPS	+	+
FCF	+	+
B_SIZE	+	+
B_ICOM	+/ins	+/ins
F_SIZE	+	+

The finding of dynamic GMM-Difference models of the impact of financial decision and control variable on firm performance are reported in table 3. There are four diagnostic test should be addressed in this study to evaluated the most appropriate estimations in dynamic GMM estimation, namely: First and Second order autocorrelation of residuals (AR(1) & AR(2)), Hansen test (*J*-statistic) of over-identifying restriction and Wald test. The results of the specification test show that the Hansen *J*-statistic of over-identifying restriction of the two models has the *p*-values of 0.1519 and 0.054 respectively. So that it can be concluded that both model has a valid instruments or over-identifying restriction are satisfied and appropriate model of ROA and TOBINS_Q, this mean the instruments used in the GMM-Difference models are not correlated with the residuals. The result of the Wald test, which is a test of joint significance, show that all coefficient are jointly equal to zero (H_0). Moreover, the Arellano-Bond test suggested that the residual were not affect by the second-order serial autocorrelation for both models, it is shows the *p*-values of AR(2) are 0.7666 and 0.0485 respectively. This means that we accept the null hypothesis of no second order autocorrelation.

Table 3: Estimation result based on GMM-Difference for equation (1.1) and (1.2)

Independent Variables	ROA	TOBINS_Q
-----------------------	-----	----------

	2 nd -Lag	1 st -Lag
ROA(-1)	0.1309 (6.800)***	
ROA(-2)	0.0214 (1.500)**	
TOBINS_Q(-1)		0.3050 (9.096)***
INV	-0.0228 (-2.965)***	-0.1694 (-4.998)***
LEV	-0.0509 (-3.585)***	0.4087 (5.235)***
DPS	0.0448 (3.627)***	0.1871 (4.446)***
FCF	0.4872 (15.737)***	-0.0186 -0.4720
B_SIZE	0.0004 0.7793	0.0106 0.8902
B_ICOM	0.0021 0.8612	0.1967 2.113)**
F_SIZE	0.0020 (0.096)*	0.0010 0.2566
Wald F-test	(116.42)***	(33.68)***
Arellano-Bond test:		
AR(1) (p-value)	0.0000	0.0000
AR(2) (p-value)	0.7367	0.0485
Hansen test (p-value)	0.1519	0.0545
Number of instrument	51	61
Observation	1696	1908

Notes: Robust standard error in parentheses *, **, *** Significant at 10, 5, 1 percent level, except *p*-value for Hansen test and Arellano-Bond test.

The results in Table 3 show that each of the lagged dependent variables ROA(-1) and ROA(-2) and TOBINS_Q (-1) is positive and significantly impact the current accounting and market performance (ROA & TOBINS_Q). This indicates that the dynamic modeling is a right specification for firm performance. The positive and significant lagged firm performance proposes that the data support the lagged effect, and firm performance is dynamic in nature. This implies that firms produced higher return on asset and firm management has the ability to use its assets efficiently and effectively to generate firm profit in previous year. Similarly, the market performance last year provides information to investors of market value of equity to investors, and encourages them to invest in the company. This study is consistent with the earlier study presented by Zeitun and Saleh (2015).

Investment has negative and significant impact on firm performance, suggest that Indonesian public companies with higher percentage of investment have lower firm performance (ROA and TOBINS_Q). The result contradicts the theoretical prediction that investment has a positive impact on firm performance. Additionally, based on the theoretical concept of investment, it suggests that when firms have higher investment or increase growth rate of total assets, it would lead firms to increase firm profitability, in which they would use their assets optimally and take only safe investment. However, in this case, this result indicates that increased investment leads to decreased accounting performance, and this implies a symptom of over-investment problem. This finding is in line with earlier studies (Bambang Sudiyatno & Elen

Puspitasari 2010; Ruzita et al. 2010), who revealed that investment has negative effect on firm performance but insignificant.

Leverage has negative and significant effects on ROA but positive and significantly affects TOBINS_Q. The negative relationship between leverage and ROA suggests that companies with a higher leverage leads to a lower ROA. This implies that firm has over-leverage which in turn affects their performance negatively. This finding supports the theoretical prediction that leverage has negative effect on firm performance. Therefore, profitable firm prefer on internal financing rather than external fund to finance their investment (Myers & Majluf 1984). This findings are consistent with the past studies such as (Shahzad et al. 2015; Vithessonthi & Tongurai 2015; Zeitun & Saleh 2015; Abu-Rub 2012; Olokoyo 2013; Ruzita et al. 2010) among others, so that this finding supported by pecking order theory. Moreover, DPS has positive and significant impact on firm performance (ROA and TOBINS_Q) of Indonesian public companies. The data support the hypothesis that dividend per share has positive effects on firm performance. This positive relationship indicates that the higher firm performance encourage firms to payout dividends to its shareholders. Nevertheless, firm with higher free cash flow should pay more dividends to the reduced agency cost as one possible solution to solve it problem of collective actions that tend to lead to under-monitoring of the firm and its management (Easterbrook 1984; Holder et al. 1998; Mollah et al. 2002). This finding is in line with earlier studies (Jensen, 1986; Imran, 2011; Ruzita et al., 2010).

In addition, free cash flow have positive and significantly on ROA but it was insignificant on TOBINS_Q. The positive relations suggested that firm with higher free cash flow lead to increase accounting firm performance specifically for large and profitable firms, in which the firm more stable net earnings as well as firm has ability to pay large dividends to shareholders. With respect to corporate governance structure measured by Board Size (B_SIZE) and Board Independent Commissioners (B_ICOM) have positive effect on ROA but insignificant. However, B_ICOM has positive and significant impact on market performance (TOBINS_Q), this implies that the positive role of independent commissioners is also consistent with theoretical prediction. Since corporate governance of Indonesia firms adopted dual board system (BOD and BOC), so that the ratio of independent commissioners has positive sign to market performance, higher number of independent commissioner leads to increase market performance. Firm size has positive and significant relationship on ROA. The positive relation suggested that higher firm size leads to increase market performance.

5. CONCLUSION

This study investigates the effect of financial decision behavior on firm performance of 212 Indonesian listed companies using dynamic panel GMM estimation method during the period 2003-2013. The results based on the GMM-difference estimation find that firm performance is dynamic in nature, indicating that the lagged firm performance is significant. This implies that the previous year's firm performance affects the current year performance. The findings of financial decision behavior indicates that financial decision behavior of Indonesian public companies seems to be important factors in determining firm performance, where the investment, capital structure and dividend policy affect financial firm performance significantly. The negative coefficient of investment suggests that the findings are consistent with the theoretical intuition of over-investment, in which managers over-invest lead to decrease firm performance. Similarly to financing decision, Indonesian firms was over-leverage, indicates that the negative impact of leverage on ROA due to agency problem between manager and shareholders, thus leads to the decrease firm performance. However, the interesting finding reveals that leverage is positive and significant on market performance (TOBINS_Q). It indicates that debt improves the Indonesian market performance which may not reflect on their

profitability. Moreover, the positive relation between DPS and TOBINS_Q shows that firm payout dividends to shareholders create good signal to the market, which is manager's uses dividend to express their private information about firm prospect of the future earning to the market.

REFERENCES

- Abu-Rub, N. 2012. Capital Structure and Firm Performance: Evidence from Palestine Stock Exchange. *Journal of Money, Investment and Banking* 23(1): 109-117.
- Amidu, M. 2007. How Does Dividend Policy Affect Performance of the Firm on Ghana Stock Exchange? *Investment Management and Financial Innovations* 4(2): 103-112.
- Baltagi, B. 2008. *Econometric Analysis of Panel Data*. Chichester, UK: John Wiley & Sons.
- Bambang Sudiyatno & Elen Puspitasari. 2010. Pengaruh Kebijakan Perusahaan Terhadap Nilai Perusahaan Dengan Kinerja Perusahaan Sebagai Variabel Intervening (Studi Pada Perusahaan Manufaktur Di Bursa Efek Indonesia). *Dinamika Keuangan dan Perbankan* 2(1): 1-22.
- Bambang Sudiyatno, Elen Puspitasari & Andi Kartika. 2012. The Company's Policy, Firm Performance, and Firm Value: An Empirical Research on Indonesia Stock Exchange. *American International Journal of Contemporary Research Vol. 2 No 12(2)*: 30-40.
- Bassey, B. E. & Inah, E. U. 2012. Capital Structure, Corporate Financial Performance and Shareholders' Investment Decisions: A Survey of Selected Nigerian Companies. *European Journal of Economics, Finance and Administrative Sciences* 54(0): 128-145.
- Berk, A. 2006. Determinants of Leverage in Slovenian Blue-Chip Firms and Stock Performance Following Substantial Debt Increases. *Post-Communist Economies* 18(4): 479-494.
- Bhattacharya, S. 1979. Imperfect Information, Dividend Policy, and "the Bird in the Hand" Fallacy". *The Bell Journal of Economics* 10(1): 259-270.
- Charles, Y., Joseph, C. & S., J. 2014. Effects of Dividend Policy on Firm's Financial Performance: Econometric Analysis of Listed Manufacturing Firms in Kenya. *Research Journal of Finance and Accounting* 5(12):
- Deangelo, H., Deangelo, L. & Stulz, R. M. 2006. Dividend Policy and the Earned/Contributed Capital Mix: A Test of the Life-Cycle Theory. *Journal of Financial Economics* 81(2): 227-254.
- Djaja, K. 2009. Impact of the Global Financial and Economic Crisis on Indonesia. A Rapid Assessment. *ILO, Secretary Coordinating Ministry for Economic Affairs, Indonesia*
- Easterbrook, F. H. 1984. Two Agency-Cost Explanations of Dividends. *The American Economic Review* 74(4): 650-659.
- Fama, E., F. & Miller, M., H. 1972. *The Theory of Finance*. New York: Holt, Rinehart, and Winston.
- Fama, E. F. 1978. The Effects of a Firm's Investment and Financing Decisions on the Welfare of Its Security Holders. *The American Economic Review* 68(3): 272-284.
- Fazzari., S. M., Hubbard., R. G. & Petersen., B. C. 1988. Financing Constraints and Corporate Investment. *Brooking Paper on Economic Activity* 1988(1): 141-195.
- Grazzi, M., Jacoby, N. & Treibich, T. 2011. Dynamic of Investment and Firm Performance: Comparative Evidence in Manufacturing Industries *DIME Final Conference*
- Hardiyanto, A. T., Achsani, N. A., Sembel, R. & Maulana, T. 2014. The Difference of Capital Structure among Industry Sectors in the Indonesia Stock Exchange. *Business and Management Review* 3(08): 28-35.

- Holder, M. E., Langrehr, F. W. & Hexter, J. L. 1998. Dividend Policy Determinants: An Investigation of the Influences of Stakeholder Theory. *Financial management* 27(0): 73-82.
- Hubbard, G. 1998. Capital Market Imperfections and Investment. *Journal of Economic Literature* 35(0): 193-225.
- Inselbag, I. 1973. Financing Decisions and the Theory of the Firm. *The Journal of Financial and Quantitative Analysis* 8(5): 763-776.
- Jensen, M. C. 1986. Agency Costs of Free Cash Flow, Corporate Finance, and Takeovers. *The American Economic Review* 76(2): 323-329.
- Jensen, M. C. & Meckling, W. H. 1976. Theory of the Firm: Managerial Behavior, Agency Costs and Ownership Structure. *Journal of Financial Economics* 3(305-360).
- John, K. & Williams, J. 1985. Dividends, Dillution, and Taxes:A Signalling Equilibrium”, . *Journal of Finance* 40(4): 1053-1070.
- Kaplan, S. N. & Zingales, L. 1997. Do Investment-Cash Flow Sensitivities Provide Useful Measures of Financing Constraints? *The Quarterly Journal of Economics* 112(1): 169-215.
- Leo Indra Wardhana, Eduardus Tandelilin, I Wayan Nuka Lantara & Junarsin, E. 2014. Dividend Policy in Indonesia: A Life-Cycle Explanation. Asian Finance Association (AsianFA) 2014 Conference Paper. Anjuran https://papers.ssrn.com/sol3/papers.cfm?abstract_id=2396267###.
- Loof, H. & Heshmati, A. 2008. Investment and Performance of Firms: Correlation or Causality? *Corporate Ownership & Control* 6(2): 268-282.
- Margaritis, D. & Psillaki, M. 2010. Capital Structure, Equity Ownership and Firm Performance. *Journal of Banking & Finance* 34(3): 621-632.
- Miller, M. H. & Modigliani, F. 1961. Dividend Policy, Growth, and the Valuation of Shares. *The Journal of Business* 34(4): 411-433.
- Miller, M. H. & Rock, K. 1985. Dividend Policy under Asymmetric Information,. *Journal of Finance*, 40(1031-1051).
- Modigliani, F. & Miller, M. 1963. Corporate Income Taxes and the Cost of Capital: A Correction, , 53, June, Pg. 433-443. *American Economic Review* 53(June): 433-443.
- Modigliani, F. & Miller, M., H. 1958. The Cost of Capital, Corporation Finance and the Theory of Investment. *The American Economic Review* 48(3): 261-297.
- Mollah, S., K. Keasey & Short, H. 2002. The Influence of Agency Costs on Dividend Policy in an Emerging Market: Evidence from the Dhaka Stock Exchange. *Working Paper*
- Murekefu, T. M. & Ouma, O. P. 2012. The Relationship between Dividend Payout and Firm Performance: A Study of Listed Companies in Kenya. *European Scientific Journal ISSN: 1857 – 7881* 8(9):
- Myers, S. C. 1977. Determinants of Corporate Borrowing. *Journal of financial economics* 5(2): 147-175.
- Myers, S. C. & Majluf, N. S. 1984. Corporate Financing and Investment Decisions When Firms Have Information That Investors Do Not Have. *Journal of financial economics* 13(2): 187-221.
- Nikolaus, V. 2015. Determinants of Firm Financial Performance in Indonesia and the Netherlands: A Comparison. 5th IBA Bachelor Thesis Conference,. Anjuran Enschede, The Netherlands., July 2nd, 2015.
- Norazlan Alias, Mohd. Hasimi Yaacob, Ruzita Abdul Rahim & Fauzias Mat Nor. 2016. Board Structure, Capital Structure and Dividend Per Share: Is There Interaction Effect? *Malaysian Journal of Society and Space* 12(2): 58-67.
- Olokoyo, F. O. 2013. Capital Structure and Corporate Performance of Nigerian Quoted Firms: A Panel Data Approach. *African Development Review* 25(3): 358-369.

- Onaolapo, A. A. & Kajola, S. O. 2010. Capital Structure and Firm Performance: Evidence from Nigeria. *European Journal of Economics, Finance and Administrative Sciences* 25): 70-82.
- Riachi, I. & Schwienbacher, A. 2015. Investment, Firm Performance and Securitization: Evidence from Industrial Companies. *Finance Research Letters* 13(17-28).
- Rozeff, M. S. 1982. Growth, Beta and Agency Cost of Determinant S of Dividend Payout Ratio. *Journal of Financial Research* 5(3): 249-259.
- Ruzita, A. R., Hasimi, M., Yaacob,., Norazlan, A. & Fauzias, M. N. 2010. Investment, Board Governance and Firm Value: A Panel Data Analysis. *International Review of Business Research Papers* 6(5): 293-302.
- Saeedi, A. & Mahmoodi, I. 2011. Capital Structure and Firm Performance: Evidence from Iranian Companies. *International Research Journal of Finance and Economics* 70(11): 20-29.
- San, O. T. & Heng, T. B. 2011. Capital Structure and Corporate Performance of Malaysian Construction Sector. *International Journal of Humanities and Social Science* 1(2): 28-36.
- Scott, J. 1977. Bankruptcy, Secured Debt, and Optimal Capital Structure. *Journal of Finance* 32(1-19).
- Shahzad, S. J. H., Ali, P., Ahmad, T. & Ali, S. 2015. Financial Leverage and Corporate Performance: Does Financial Crisis Owe an Explanation? *Pakistan Journal of Statistics and Operation Research* 11(1): 67-90.
- Stulz, R. M. 2000. Merton Miller and Modern Finance. *Financial Management* 29(119-131).
- Tan, J. & Wang, L. 2010. Flexibility-Efficiency Tradeoff and Performance Implications among Chinese Soes. *Journal of Business Research* 63(4): 356-362.
- Tobin, J. 1969. A General Equilibrium Approach to Monetary Theory. *Journal of Money, Credit and Banking* 1(1): 15-29.
- Uwuigbe, U., Jafaru, J. & Ajayi, A. 2012. Dividend Policy and Firm Performance: A Study of Listed Firms in Nigeria. *Accounting and Management Information Systems* 11(3): 442.
- Velnampy, T., Nimalthasan, M. P. & Kalaiarasi, M. K. 2014. Dividend Policy and Firm Performance: Evidence from the Manufacturing Companies Listed on the Colombo Stock Exchange. *Global Journal of Management And Business Research* 14(6):
- Vithessonthi, C. & Tongurai, J. 2015. The Effect of Firm Size on the Leverage-Performance Relationship During the Financial Crisis of 2007-2009. *Journal of Multinational Financial Management* 29(1-29).
- Wang, G. Y. 2010. The Impacts of Free Cash Flows and Agency Costs on Firm Performance. *Service Science & Management*, 3(4): 408-418.
- Wintoki, M. B., Linck, J. S. & Netter, J. M. 2012. Endogeneity and the Dynamics of Internal Corporate Governance. *Journal of Financial Economics* 105(3): 581-606.
- Zeitun, R. & G.Tian, G. 2007. Capital Structure and Corporate Performance: Evidence from Jordan *Australasian Accounting Business and Finance Journal* 1(4): 40.
- Zeitun, R. & Saleh, A. S. 2015. Dynamic Performance, Financial Leverage and Financial Crisis: Evidence from Gcc Countries. *EuroMed Journal of Business* 10(2): 147-162.

PROOF COVER SHEET

Journal acronym: OAEF

Author(s): Darmawati Muchtar, Fauzias Mat Nor, Wahyuddin Albra,
Muhammad Arifai and Ansari Saleh Ahmar

Article title: Dynamic performance of Indonesian public companies: An analysis of financial decision
behavior

Article no: 1488343

Enclosures: 1) Query sheet
2) Article proofs

Dear Author,

Please find attached the proofs for your article.

1. Please check these proofs carefully to identify any errors that may have arisen during the writing or production process. Cogent OA requires that the corresponding author checks and approves these proofs in order to proceed with publication.

Please limit any changes to the correction of errors. We are not able to make stylistic changes, or add or delete material at this stage.

We generally expect there to be no more than 30 minor corrections during this proof stage. Your PDF proof file has been enabled so that you can comment on the proof directly using Adobe Acrobat. This is the easiest and clearest way for you to ensure that your corrections will be incorporated.

Queries are marked in the margins of the proofs, and you can also click the hyperlinks below. Content changes made during copy-editing are shown as tracked changes. Inserted text is in **red font** and revisions have a red indicator ▲. Changes can also be viewed using the list comments function. To correct the proofs, you should insert or delete text following the instructions after the author queries below, but **do not add comments to the existing tracked changes**.

2. Please review the table of contributors below and confirm that the first and last names are structured correctly and that the authors are listed in the correct order of contribution. This check is to ensure that your names will appear correctly online and when the article is indexed.

Sequence	Prefix	Given name(s)	Surname	Suffix
1		Darmawati	Muchtar	
2		Fauzias	Mat Nor	
3		Wahyuddin	Albra	
4		Muhammad	Arifai	
5		Ansari Saleh	Ahmar	

AUTHOR QUERIES

General points:

1. **Permissions:** You have warranted that you have secured the necessary written permission from the appropriate copyright owner for the reproduction of any text, illustration, or other material in your article. For further guidance on this topic please see:
<http://journalauthors.tandf.co.uk/copyright/usingThirdPartyMaterial.asp>.
2. **Third-party material:** If there is material in your article that is owned by a third party, please check that the necessary details of the copyright/rights owner are shown correctly.
3. **Affiliation:** The corresponding author is responsible for ensuring that address and email details are correct for all the co-authors. Affiliations given in the article should be the affiliation at the time the research was conducted. For further guidance on this topic please see:
<http://journalauthors.tandf.co.uk/preparation/writing.asp>.
4. **Funding:** Please include details of any funders for your research at the end of the article under a heading of 'Funding'. If the research is supported by a funding agency please insert the phrase 'This work was supported by <insert the name of the funding agency in full >', followed by the grant number in square brackets '[grant number xxxx]'.
Data can be deposited, stored and linked to freely on services such as Figshare (www.figshare.com). We also encourage the inclusion of supplemental information that supports and enriches your article (eg, short video or audio files, additional figures and tables). Where this has been provided, it will appear alongside the published article online and a link will be included by Cogent OA on the PDF of your article. For further information on this topic please see:
<http://journalauthors.tandf.co.uk/preparation/supplementalMaterial.asp>.
5. **Supplemental / supporting information and underlying research data:** Where applicable, we encourage you to provide a link to the data underlying your research (e.g. samples, models, survey data). If you are able to do so, please insert this sentence before the reference section: 'The underlying research data for this article can be accessed at <full link>/ description of location [author to complete]'.
Data can be deposited, stored and linked to freely on services such as Figshare (www.figshare.com). We also encourage the inclusion of supplemental information that supports and enriches your article (eg, short video or audio files, additional figures and tables). Where this has been provided, it will appear alongside the published article online and a link will be included by Cogent OA on the PDF of your article. For further information on this topic please see:
<http://journalauthors.tandf.co.uk/preparation/supplementalMaterial.asp>.
6. The **CrossRef database** (www.crossref.org/) has been used to validate the references. Mismatches will have resulted in a query below.

- AQ1** Please note that the ORCID for Ahmar Ansari Saleh has been created from information provided through CATS. Please correct if this is inaccurate.
- AQ2** Please provide missing City for the affiliation
- AQ3** Please provide missing City for the affiliation
- AQ4** Please define ROA
- AQ5** Please define ROA.
- AQ6** The reference "Babatunde & Olaniran 2009" is cited in the text but is not listed in the references list. Please either delete in-text citation or provide full reference details following journal style [http://www.tandf.co.uk/journals/authors/style/reference/tf_APA.pdf]
- AQ7** The reference "Burca & Batrinca 2014" is cited in the text but is not listed in the references list. Please either delete in-text citation or provide full reference details following journal style [http://www.tandf.co.uk/journals/authors/style/reference/tf_APA.pdf]
- AQ8** The reference "Liow 2010" is cited in the text but is not listed in the references list. Please either delete in-text citation or provide full reference details following journal style [http://www.tandf.co.uk/journals/authors/style/reference/tf_APA.pdf]

- AQ9** The reference “Mirza & Javed 2013” is cited in the text but is not listed in the references list. Please either delete in-text citation or provide full reference details following journal style [http://www.tandf.co.uk/journals/authors/style/reference/tf_APA.pdf]
- AQ10** The reference “Ahmar et al. (2017)” is cited in the text but is not listed in the references list. Please either delete in-text citation or provide full reference details following journal style [http://www.tandf.co.uk/journals/authors/style/reference/tf_APA.pdf]
- AQ11** The reference “Miller 1977” is cited in the text but is not listed in the references list. Please either delete in-text citation or provide full reference details following journal style [http://www.tandf.co.uk/journals/authors/style/reference/tf_APA.pdf]
- AQ12** The reference “Norazlan Alias et al.” is cited in the text but is not listed in the references list. Please either delete in-text citation or provide full reference details following journal style [[hyperlink to relevant style-sheet](#)].
- AQ13** Please check and verify whether this is the full form of ROA and should be used to define ROA at the first instance in this article.
- AQ14** The reference “Olokoyo 2013” is cited in the text but is not listed in the references list. Please either delete in-text citation or provide full reference details following journal style [http://www.tandf.co.uk/journals/authors/style/reference/tf_APA.pdf]
- AQ15** The reference “Imran, 2011” is cited in the text but is not listed in the references list. Please either delete in-text citation or provide full reference details following journal style [http://www.tandf.co.uk/journals/authors/style/reference/tf_APA.pdf]
- AQ16** The CrossRef database (www.crossref.org/) has been used to validate the references. Mismatches between the original manuscript and CrossRef are tracked in red font. Please provide a revision if the change is incorrect. Do not comment on correct changes.
- AQ17** Please provide missing page number for the “Charles et al., 2014” references list entry.
- AQ18** Please provide missing editor name or institutional editor name/Publisher name/publisher location for the “Djaja, 2009” references list entry.
- AQ19** Please provide missing conf-loc for the “Grazzi et al., 2011” references list entry.
- AQ20** Please provide missing page number for the “Murekefu and Ouma, 2012” references list entry.
- AQ21** Please provide missing volume number/page number for the “Suta, 2006” references list entry.
- AQ22** Please provide missing page number for the “Velnampy et al., 2014” references list entry.
- AQ23** Please provide missing conf-loc for the “Yu and Li, 2011” references list entry.

How to make corrections to your proofs using Adobe Acrobat/Reader

Taylor & Francis offers you a choice of options to help you make corrections to your proofs. Your PDF proof file has been enabled so that you can mark up the proof directly using Adobe Acrobat/Reader. This is the simplest and best way for you to ensure that your corrections will be incorporated. If you wish to do this, please follow these instructions:

1. Save the file to your hard disk.
2. Check which version of Adobe Acrobat/Reader you have on your computer. You can do this by clicking on the “Help” tab, and then “About”.

If Adobe Reader is not installed, you can get the latest version free from <http://get.adobe.com/reader/>.

3. If you have Adobe Acrobat/Reader 10 or a later version, click on the “Comment” link at the right-hand side to view the Comments pane.

4. You can then select any text and mark it up for deletion or replacement, or insert new text as needed. Please note that these will clearly be displayed in the Comments pane and secondary annotation is not needed to draw attention to your corrections. If you need to include new sections of text, it is also possible to add a comment to the proofs. To do this, use the Sticky Note tool in the task bar. Please also see our FAQs here: <http://journalauthors.tandf.co.uk/production/index.asp>.

5. Make sure that you save the file when you close the document before uploading it to CATS using the “Upload File” button on the online correction form. If you have more than one file, please zip them together and then upload the zip file.

If you prefer, you can make your corrections using the CATS online correction form.

Troubleshooting

Acrobat help: <http://helpx.adobe.com/acrobat.html>

Reader help: <http://helpx.adobe.com/reader.html>

Please note that full user guides for earlier versions of these programs are available from the Adobe Help pages by clicking on the link “Previous versions” under the “Help and tutorials” heading from the relevant link above. Commenting functionality is available from Adobe Reader 8.0 onwards and from Adobe Acrobat 7.0 onwards.

Firefox users: Firefox’s inbuilt PDF Viewer is set to the default; please see the following for instructions on how to use this and download the PDF to your hard drive:

http://support.mozilla.org/en-US/kb/view-pdf-files-firefox-without-downloading-them#w_using-a-pdf-reader-plugin



FINANCIAL ECONOMICS | RESEARCH ARTICLE

Dynamic performance of Indonesian public companies: An analysis of financial decision behavior

Darmawati Muchtar¹, Fauzias Mat Nor², Wahyuddin Albra¹, Muhammad Arifai³ and Ansari Saleh Ahmar^{4*}

Received: 1 February 2018
Accepted: 10 June 2018

*Corresponding author: Ansari Saleh Ahmar, Statistics, Universitas Negeri Makassar, Indonesia
E-mail: ansarisaleh@unm.ac.id

Reviewing editor:
Mohammed M Elgammal, Finance and Economics, University of Qatar, Qatar

Additional information is available at the end of the article

Abstract: The purpose of this research is to investigate the effects of financial decision behavior on firm performance of Indonesian public companies using panel data. The dynamic generalized method of moment is utilized in this study. The results show that firm performance is dynamic in nature, which indicates that last year performance affects current performance significantly. Empirical result of financial decision behavior shows that investment, leverage, and dividend per share (DPS) have significant impact on firm performance. Specifically, investment has negative impact on firm performance. Meanwhile leverage has negative effects on ROA, but positively affects Tobin's Q. Moreover, DPS positively affects ROA and Tobin's Q. This finding suggests that investment decision of Indonesian firms is overinvestment, indicated with higher investment affects firm performance negatively. Similarly with leverage, the finding reveals that Indonesian public companies borrowed external fund more than they required (overleverage). The positive effect of DPS on firm performance implies that dividends payout to shareholders create

5

10

15

AQ4

20



Darmawati Muchtar

ABOUT THE AUTHORS

Darmawati Muchtar is a lecture in Finance at Faculty of Economic and Business, Universitas Malikussaleh (UNIMAL), Aceh-Indonesia. She received her D.B.A (Finance) from the Graduate School of Business, Universiti Kebangsaan Malaysia in 2017.

Fauzias Mat Nor is a professor of finance at Universiti Sains Islam Malaysia. Her research interest is on Islamic Finance with special focus on Corporate Finance and Banking. Prior to joining USIM, in 2015, she has served UKM for more than 29 years as a lecturer, an Associate Professor and Professor in Finance.

Wahyuddin Albra is a lecturer in Department of Management at Faculty of Economic and Business, Universitas Malikussaleh (FEB-UNIMAL), Aceh-Indonesia. Now he is a Dean at FEB-UNIMAL, Aceh, Indonesia.

Muhammad Arifai is a lecturer at Department of Accounting, Lhokseumawe State of Polytechnic, Aceh, Indonesia.

Ansari Saleh Ahmar is a lecturer at Department of Statistics, Universitas Negeri Makassar, Makassar, Indonesia.

PUBLIC INTEREST STATEMENT

Firm management has an important role to increase firm profitability and maximize shareholders' wealth. Hence, managers should act on behalf of shareholders' interest to enhance firm performance. Generally, the financial performance measures are categorized into the accounting-based and the market-based measures. Firm performance is determined by various factors, of which that the internal and external factors play an important role in determining firm performance. Thus, financial decision behavior; such as investment, financing decision, and dividend policy becomes important role for managers in allocating fund resources. Firms with higher internal fund tend to overinvest in unprofitable investment instead of paying dividend to shareholders. The results of this research show that firm performance is dynamic in nature, indicates that last year performance has impact on current performance. Investment, leverage, and dividend policy become important factors that determine firm performance. However, the impacts are more on the market

good signal to the market, in which managers uses dividend to deliver private information to the market. However, based on the coefficient of financial decision variables, the impact is more on the market performance and less on the accounting performance. 25

Subjects: Financial Mathematics; Corporate Finance; Investment & Securities

Keywords: Financial decision; dynamic performance; GMM-difference

1. Introduction

This study deals with an important issue in corporate finance, in which we investigate the dynamic firm performance and financial decision behavior. Even though most of prior studies of firm performance and financial decision have been done, but still interesting to be analyzed and discussed, in fact that a firm periodically makes three major important financial policies that determine the value of firm. Firm performance is associated with the concepts of productivity, efficiency, and effectiveness of corporate management in utilizing resources optimally (Tan & Wang, 2010). These concepts correlated to the size of the firm: A small firm is more efficient than a large firm due to the former's absence of agency problems, flexibility, and nonhierarchical structure (Halkos & Tzeremes, 2007). Past studies proposed that Indonesia firms had good market performance, which recoded the average of Tobin's Q was valued at 1.13% for period 2009 to 2013 (Nikolaus, 2015), and the profitability (ROA) of manufacturing firm was valued at 12.69% (Bambang Sudiyatno, Puspitasari, & Kartika, 2012). Hence, financial decision policy plays an important role to enhance firm performance. 30 35 AQ5

The value of firm is determined by investment decision (Fama, 1978), although in perfect capital market investment decision is independent of the financial structure. This is because external funds serve as a perfect replacement for internal capital (Modigliani & Miller, 1958). In contrast, empirical research shows that internal and external capitals do not perfectly substitute each other in the short run, meaning that investment should be dependent on financial factors, so that both investment and financing decisions are interdependent in imperfect capital market, and the debt financing influences value of the firms (Modigliani & Miller, 1963). Additionally, several earlier studies on investment decisions have been widely discussed in relation of the cash flow and investment level to analyze the problems of over- and underinvestment (Fazzari, Hubbard, & Petersen, 1988; Hubbard, 1998; Kaplan & Zingales, 1997), the overinvestment occurs when firms have excess internal funds (Jensen, 1986). Empirical studies of Indonesian firms found that investment has negative effect on firm performance but not significant (Bambang Sudiyatno et al., 2012). Another issue is the global financial crisis impacted the economic and manufacturing firms turn to lower investment and capital market confidence plunged significantly (Djaja, 2009). 45 50 55

Regarding financing decision, the issues occur when companies assess their financial needs, their borrowing capacity and their ability to generate shareholder returns and maximize the firm value. Therefore, financing decision and policy to raise financial resources are among very important considerations. The consequence of higher leverage, firm may suffer agency cost and bankruptcy. Therefore, financial leverage and firm performance have negative relationship (Jensen & Meckling, 1976; Myers, 1977). However, some researchers argue that financial leverage and firm performance have positive relation because debt financing implies a commitment on managers to payout more cash, and discipline managers by restricting the amount of free cash flow (FCF) under their control (Jensen, 1986). In Indonesia, the level of leverage is highest for the period 2005-2011, which shows the average debt-to-equity ratio has valued at 57% in various industry sector (Hardiyanto, Achسانی, Sembel, & Maulana, 2014). 60 65

Lastly, dividend policy issue of firm performance, in which dividend itself having implicit private information and is a signaling device to influence stock price (Bhattacharya, 1979; John & Williams,

1985; Miller & Rock, 1985). Thus, when a firm announces an increasing dividend, it is a sign of good news in the capital market with positive reaction of share price. Therefore, only good performance firms can send signals to the market using dividends. However, dividend policy appears to have a matter in firm behavior, in this case, the issue of why the firm should pay dividends or hold dividend payout is still unresolved. This is due to the fact that many listed companies in Indonesia do not pay dividends regularly. One explanation is that the firm is deferring dividend payments because the firm needs more funds to finance its investment specifically during the financial crisis. In Indonesia, the propensity of the firm to pay dividend has decline over time and dividend life cycle explains well the dividend policy (Leo Indra Wardhana, Tandellilin, Wayan Nuka Lantara, & Junarsin, 2014).

Accordingly, we argue corporate financial decision as important factors affect firm performance. Although most studies have been conducted in many perspectives, phenomena and empirical evidence, such as studies of corporate finance behavior, equity, leverage, total market share, investment ratio, growth, profitability, size, and corporate governance (Babatunde & Olaniran, 2009; Burca & Batrinca, 2014; Fauzias Mat Nor, Azlan, & Hasimi, 2011; Liow, 2010; Mirza & Javed, 2013; Nikolaus, 2015). These findings provided the mixed results and still inconclusive, possibly because they used different measurements, time dimension, and firm effect. Therefore, this study aims to close the gap in the existing literature by analysis the issue of corporate financial decision behavior and firm performance. Hence, this study proposes to investigate the impact of investment, leverage, and dividend per share (DPS) on firm performance.

This study apply the dynamic panel model uses generalized method of moment (GMM)-first difference estimator for the advanced statistical analysis to overcome the endogeneity issue in corporate finance. The first lagged of firm performance are likely to be endogenous or highly correlated with the dependent variables, so that they are correlated with the error term. Therefore, the ordinary least square (OLS) or static panel model estimation method (fixed effect model and random effect model) would not be an appropriate method or would be bias for estimating the model parameters. Thus, it can be used to control for the dynamic nature of relationship between firm performance and financial decision behavior while accounting for other sources of endogeneity in corporate finance research (Wintoki, Linck, & Netter, 2012).

Therefore, to provide additional evidence on the impact of financial decision on firm performance, the present study contributes to the existing literature by providing economic justification for use of dynamic panel GMM estimation for both accounting and market performance. The rest of this paper is organized as follows. Section 2 reviews the literature and hypotheses are developed. Sections 3 and 4 describe the methodology and empirical results, respectively whereas Section 5 concludes.

2. Literature review

2.1. Investment and firm performance

The relationship between investment and firm performance has been examined by several prominent researchers from underpinning theories of investment (Fama, 1978; Modigliani & Miller, 1958; Tobin, 1969). The Tobin's Q becomes a central theoretical model of investment and provides an empirical framework for analyzing individual firm's financial decisions. It is also a popular proxy for the unobservable investment opportunities based on market value. Fama and Miller (1972) proposed that the market value of a firm is the discounted value of expected future cash flows from all its investment in the present and future; that is, an increase in capital expenditure will have a positive impact on a firm's market performance. Earlier on, Del Brio, De Miguel, and Pindado (2003) study on investment and firm value, the result suggests that the positive or negative market reactions to investment (divestment) announcement persist over time. This implies that the increase in firm value is greater for the firm with valuable investment opportunities and when firms divesting is a sign of decrease in value for the firms with valuable investment opportunities.

However, Investment in stock market has been studied by Ahmar et al. (2017) the results found that Sutte indicators are better in predicting stock price movement. AQ10

According to overinvestment theory, it proposes that firm with higher FCF_t tend to invest in negative NPV project (Jensen, 1986), and it is more serious to occur for rich firm and firm with higher concentrate ownership (Yu & Li, 2011). Previous several empirical studies indicate a significant and negative relationship between investment and firm performance but insignificant (Sudiyatno & Puspitasari, 2010). Similarly Loof and Heshmati (2008), also found negative and insignificant. Moreover, other studies focused on the effect of investment and firm performance with different measurements. For instance several studies found a positive relationship and significant between firm performance and investment (Grazzi, Jacoby, & Treibich, 2011; Kaplan & Zingales, 1997; Riachi & Schwienbacher, 2015), and others also found investment have positive impact on firm performance, but its insignificant (Ruzita, Hasimi, Yaacob, & Fauzias, 2010; Ye & Yuan, 2008). Recently, Hashmi, Mirza, and Us Sehar (2016), investigated the effect of investment measures by the capital expenditure on Tobin's Q, and they found that investment positively affects investment opportunities (Tobin's Q) for the manufacturing sectors of Pakistan companies in 2000-2008. Accordingly, increase in the capital expenditure would lead a positive impact on market performance. Hence, this study posits the following hypotheses: 120 125 130

H1a: There is a positive and significant impact of investment on accounting performance (ROA). 135

H1b: There is a positive and significant impact of investment on market performance (TOBIN'S Q).

2.2. Leverage and firm performance

The studies of the effect of leverage on firm performance has been developed by numerous prominent scholars from a broad range of underpinning theory (Miller, 1977; Modigliani & Miller, 1958, 1963), and three others major theories of financial structure decision (Harris & Raviv, 1991; Jensen & Meckling, 1976; Kraus & Litzenberger, 1973; Myers & Majluf, 1984). Modigliani and Miller (1958) posited that in a perfect capital market, firm value is independent of its capital structure, and implies that the total value of the firm is not affected by ratio of debt. A number of researchers conducted empirical work to show the changes in level of debt that have impact on the total market value of the firm. So that, the firm value reflects a valuation by shareholders, including the value perquisites consumed by manager as the agent of shareholders (Jensen & Meckling, 1976). However, the trade-off theory stated that when the firm has a higher profitability rate, the expected cost of distress would decrease, and the firms will prefer to use debt financing because of their raised leverage, even if it increases the risk of bankruptcy and financial distress (Scott, 1977). The pecking order theory explained the firms are more likely to use the internal funds and prefer debt to equity when external financing is needed, then therefore, the pecking order theory concluded that issuing debt is not for companies with more funds and liquid (Myers & Majluf, 1984). 140 145 150

The relationship between capital structure and firm performance has been investigated by many researchers with mixed results. Earlier empirical studies supported the capital structure theory proposed by Modigliani and Miller (1963), which argued that firm using debt to finance their investment, may increase firm value. Moreover, profitable firm use more debt to solve agency problem between manager and shareholders (Jensen, 1986). Thus, some studies found a positive relationship between financial leverage and firm performance (Abu-Rub, 2012; Bassey & Inah, 2012; San & Heng, 2011; Zeitun & G.Tian, 2007). In contrast, other studies indicated a significant and negative relationship between firm performance and financial leverage (Onaolapo & Kajola, 2010; Saeedi & Mahmoodi, 2011; Vithessonthi & Tongurai, 2015; Zeitun & Saleh, 2015). Furthermore, similarly with studies proposed by Shahzad, Ali, Ahmad, and Ali (2015), found that leverage negatively affect accounting performance (ROA), and short-term debt has positive effect on market performance (Tobin's Q). Therefore, based on the pecking order theory and the trade-off theory, this study posits the following hypotheses: 155 160 165

H2a: There is a negative and significant impact of leverage on accounting performance (ROA).

H2b: There is a positive and significant impact of leverage on market performance (TOBIN'S Q).

2.3. Dividend policy and firm performance

The relationship between dividend policy and firm performance has received a lot of attention in past studies. Various theories have been proposed by academicians on the principles of dividend policies that have been described as either irrelevant or relevant theory in making financial decision (Deangelo, Deangelo, & Stulz, 2006; Miller & Modigliani, 1961; Stulz, 2000). Miller and Modigliani (1961) stated that dividend policy is irrelevant for the cost of capital, and that the value of the firm is determined by its earning power and risk. The agency theory explained about dividend payment increases firm value (Easterbrook, 1984). He argued that dividend payments may act as one form of bonding cost. The transaction cost theory implies that dividend payment reduces in value because they lead to rising external financial costs. Moreover, firms with insufficient cash flow have greater dependency on external finance, and should maximize shareholders wealth by accepting lower payout policies (Rozeff, 1982). The empirical evidence proposed that firms with a higher FCF_u should pay more dividends to decrease agency cost (Holder, Langrehr, & Hexter, 1998; Mollah, Keasey, & Short, 2002). In addition, relating to dividend payment the firms paying dividend are significantly having greater cash flows (Berk, 2006).

The signaling hypothesis is consistent with Lintner (1956), suggests that managers are typically concerned with dividend stability and believe that the market has a good response to a stable dividend policy. Therefore, by paying dividend, the level of dividend changes; thus, the information is released to the market as a good signal and the price volatility reduced, and it influences the share price. The relationship between dividend policy and firm performance have been addressed (Amidu, 2007; Charles, Joseph, & Sang, 2014; Murekefu & Ouma, 2012; Uwuigbe, Jafaru, & Ajayi, 2012) found that dividend policy has positive relation on firm performance. In addition, the value of the signal depends on the level of information asymmetries in the market. In conclusion, it can be argued that information is important to reveal whether the dividend signal should be sent, and its effect on prices as well as on firm value. Thus, this study posits the following hypotheses:

H3a: There is a positive and significant impact of DPS on accounting performance (ROA).

H3b: There is a positive and significant impact of DPS on market performance (TOBIN'S Q).

3. Conceptual framework

This study aims to investigate the impact of financial decision behavior on firm performance of Indonesia public companies. There are three important financial decision that determine firm performance, namely, investment, leverage, and dividend policy. Various theories that support the relationship between financial decision factors (investment, leverage, and dividend policy) have been described in Section 2, such as investment theory, agency theory, pecking order theory, trade-off theory, and signaling theory. Financial performance is an important key indicator for the firm survival and an essential indicator for measuring the overall corporate performance; thus firm performance measurements are commonly classified into the accounting-based and market-based measures (Abu-Rub, 2012; Bhagat & Black, 2002; Fauzias Mat Nor et al., 2011; Khan, Nadeem, Islam, Salman, & Gill, 2016; Suta, 2006). Thus, this study focuses on ROA as the accounting performance and TOBIN'S Q as the market performance.

The conceptual framework of this study develops to linking the independent and dependent variable. Thus, the investment, leverage, and DPS_u uses as independent variables, then FCF_u , board size (B_SIZE), board independent commissioners (B_ICOM) and firm size as control variables. Furthermore, the hypotheses are developed based on the theoretical background and empirical studies discussed in

Figure 1. Research framework.

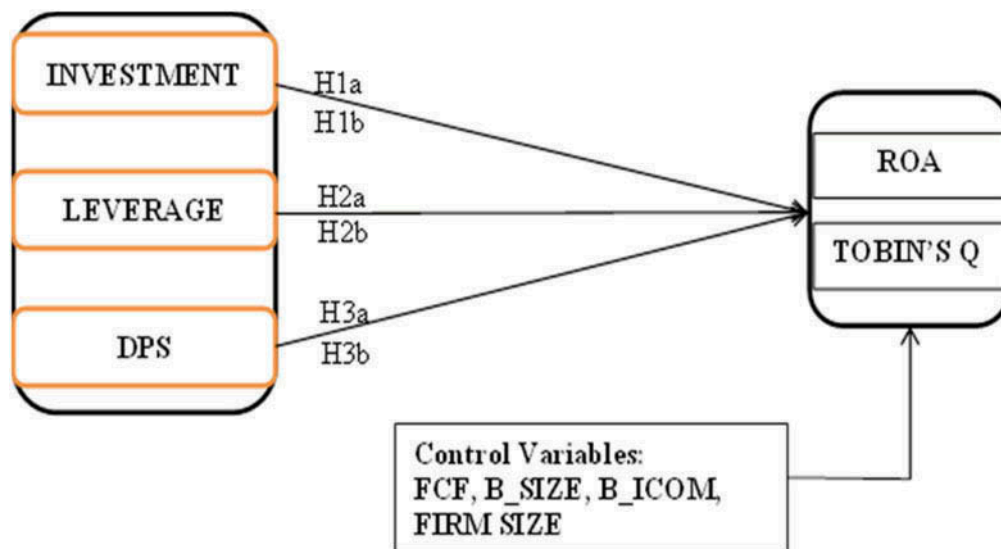

the literature review. Therefore, this study proposes three sets of the hypotheses towards achieving the research objectives. Based on the theoretical underpinnings, the research framework is derived, indicating the direction of the hypothesized relationships between the main constructs (financial decision and firm performance). The research framework of this study is presented in Figure 1

4. Methodology

To investigate the impact of financial decision behavior on firm performance, this study uses yearly of 212 nonfinancial listed firms for the period from 2003 to 2013. The data are gathered from the annual report of companies include book value of total assets and total debt, net income, market value of equity, DPS_t and other financial data used in this study also corporate board structure. The data are retrieved from the latest version 2.1 of Datastream and annual report of companies. Therefore, this study has annual observation of over than 11 years period per company, producing a balanced panel data of 2332 unit observations for data analysis.

This study used numerical variables to measures dependent and independent variables. Firm performance defined as a bivariate dependent variable by two measurements, namely accounting-base performance and market-based performance (ROA and TOBIN'S Q). ROA is defined as the ratio of net profit divided by total assets. TOBIN'S Q is the ratio of market value of equity plus book value of the total debt divided by the book value of total assets each firm and years (Fauzias Mat Nor et al., 2011; Velnampy, Nimalthasan, & Kalaiarasi, 2014; Zeitun & Saleh, 2015). The independent variables of financial decision behavior are investment, capital structure and dividend policy. Investment is presented as the exponential growth rate of total asset of the firm i , at the time t , calculated as log natural of total asset at the time/year t divided by total assets at previous year ($t-1$) (Norazlan Alias et al.; Ruzita et al., 2010). Capital structure is a combination of debt and equity and the level of it debt is referred to as leverage ratio. This study defined leverage as the ratio of total debt to total asset (Saeedi & Mahmoodi, 2011; Zeitun & Saleh, 2015). Meanwhile, the DPS_t was used to measure dividend policy in this study. DPS_t is the total amount of dividends paid to the total of share outstanding (Charles et al., 2014; Velnampy et al., 2014).

Furthermore, the FCF_t , board size (B_SIZE), board independent commissioners (B_ICOM) and sales are used as control variables. The FCF is the ratio of the total of (EBIT and depreciation) minus the total of (interest, tax, and dividend) divided by book value of total asset (Alias, Rahim, Nor, & Yaacob, 2012; Ruzita et al., 2010; Wang, 2010). Corporate governance measured by board size and

board of commissioners independent. Board size (B_SIZE) is total number of directors have been employed by (Guo & Kga, 2012; Shahzad et al., 2015; Wintoki et al., 2012; Zeitun, 2014) and BOC Independent (B_ICOM) is measured by calculating the proportion of independent commissioners with respect to the total commissaries as measured by (Jaffar, Mardinah, & Ahmad, 2013; Magdalena, 2012; Zabri, Ahmad, & Wah, 2016). Meanwhile, firm size is the natural logarithms of the total sales (Margaritis & Psillaki, 2010; Alias, Yaacob, Rahim, & Nor, 2016; Wang, 2010).

In order to discover relationship between independent and dependent variable, the dynamic GMM estimator is utilized in this study. The first lagged of firm performance are likely to be endogenous or highly correlated with the dependent variables, so that they are correlated with the error term. Therefore, the OLS or static model estimation method would not be an appropriate method or would be bias for estimating the model parameters. Following the extension of the panel data analysis presented by Baltagi (2008), the multiple regression model applied in this study is the p th order lagged variable model with the following general equation;

$$Y_{it} = \beta_0 + \sum_{j=1}^p \beta_j \times Y_{i,t-j} + \sum_{k=1}^K \delta_k \times X_{k,it} + u_{it} \quad (1)$$

where the dependent variable is each of the variables firm performance (ROA and TOBIN'S Q), and the independent variables are all defined determinant variables. So we have the following two general equations, for $t > p$, where the integer p will be selected so that the lagged variables models fit the data. The empirical equation as follows:

$$ROA_{it} = \beta_0 + \beta_1 ROA(-1) + \dots + \beta_p ROA(-p) + \delta_1 INV_{it} + \delta_2 LEV_{it} + \delta_3 DPS_{it} + \delta_4 FCF_{it} + \delta_5 B_SIZE_{it} + \delta_6 B_ICOM_{it} + \delta_7 F_SIZE_{it} + \varepsilon_{it} \quad (2)$$

$$TOBINS_Q_{it} = \beta_0 + \beta_1 TOBINS_Q(-1) + \dots + \beta_p TOBINS_Q(-p) + \delta_1 INV_{it} + \delta_2 LEV_{it} + \delta_3 DPS_{it} + \delta_4 FCF_{it} + \delta_5 B_SIZE_{it} + \delta_6 B_ICOM_{it} + \delta_7 F_SIZE_{it} + \varepsilon_{it} \quad (3)$$

Furthermore, note that the regression of dynamic panel model in Equations (2 and 3) in fact is an additive model of Y , and a single numerical determinant, such as $Y(-1)$ INV, LEV, and DPS as independent variables and FCF B_SIZE, B_ICOM, F_SIZE as control variables.

5. Discussion of results

The summary of descriptive statistical analysis of the variables used in this research is based on the final sample of 212 companies. The descriptive indicators' result is presented in Table 1, the results show that the mean of firm performance for both ROA and TOBIN'S Q are 3.8% and 101%, respectively. TOBIN'S Q has greater standard deviation of 62.7% compared to ROA with a standard deviation of 12.7%. This value indicates that the data of return on assets (ROA) has the lowest fluctuation for each company compared to others. TOBIN'S Q has the highest fluctuation compared to financial decision variables. On average, the investment is about 9% with standard deviation is 23.59%. Leverage has average is about 27.52% with standard deviation 20.79% and DPS has average about 968 rupiah and with standard deviation 3.254.

Table 2 presents the correlation between firm performance (ROA and TOBIN'S Q) and the financial decision (INV, LEV, and DPS) and other variables (B_SIZE, B_ICOM and F_SIZE). In Table 5.2 shows that accounting performance reported to be positive correlation with the investment, DPS, FCF, board size, and firm size but negatively correlated with leverage. Moreover, TOBIN'S Q are reported to be positive correlated with DPS, FCF, board size, and firm size but investment, leverage, and independent commissioner's shows insignificant correlation.

The finding of dynamic GMM-Difference models of the impact of financial decision and control variable on firm performance are reported in Table 3. There are four diagnostic tests that should be addressed in this study to evaluate the most appropriate estimations in dynamic GMM estimation,

Table 1. Descriptive statistic of the numerical research variables

Variables	Mean	Median	Max	Min	Std. Dev.	Skewness	Kurtosis	JB	Obs.
ROA	0.0379	0.0313	0.9917	-0.9866	0.1270	-0.5958	16.8420	18,755.3	2332
TOBIN'S Q	1.0147	0.8275	3.2280	0.1012	0.6268	1.2579	4.1694	747,824	2332
INV	0.0893	0.0817	1.3715	-2.0067	0.2359	-0.9570	15.5266	15,602.8	2332
LEV	0.2752	0.2438	0.9867	0.0002	0.2079	0.6930	2.9166	187,348	2332
DPS	0.0968	0.0000	5.6823	0.0000	0.3254	8.5995	110.8409	1,158,759	2332
FCF	0.0712	0.0650	1.9703	-1.7842	0.1823	0.5834	45.6401	176,799	2332
B_SIZE	4.3568	4.0000	13.0000	1.0000	1.8716	1.2604	4.6983	897,646	2332
B_ICOM	0.3027	0.3300	0.5000	0.2000	0.0841	0.6723	3.3780	189,533	2332
F_SIZE	20.6137	20.7748	25.9905	0.0000	2.3516	-3.6946	33.9780	98,549.7	2332

Notes: ROA is Return on asset, TOBIN'S Q is market value of equity plus book value of total debt over book value of total assets, LEV is leverage, DPS is dividend per share, FCF is free cash flow, B_SIZE is board size, B_ICOM is board independent commissioners and F_SIZE is firm size.

Table 2. The correlation signs of independent variables with firm performance

Independent variables	ROA	TOBIN'S Q
INV	+	+/ins
LEV	-	+/ins
DPS	+	+
FCF	+	+
B_SIZE	+	+
B_ICOM	+/ins	+/ins
F_SIZE	+	+

Notes: The sign ± is positive or negative significant, ins is insignificant, ROA is Return on Asset, INV is investment measured by natural logarithm of growth total assets, LEV is leverage measured by total debt to total assets, DPS is dividend per share, FCF is free cash flow, B_SIZE is board size, B_ICOM is board of independent commissioners and F_SIZE is firm size.

Table 3. Estimation result based on GMM-Difference for Equations (1.1) and (1.2).

Independent variables	ROA	TOBIN'S Q
	Second-Lag	First-Lag
ROA(-1)	0.1309 (6.800)***	
ROA(-2)	0.0214 (1.500)**	
TOBIN'S Q(-1)		0.3050 (9.096)***
INV	-0.0228 (-2.965)***	-0.1694 (-4.998)***
LEV	-0.0509 (-3.585)***	0.4087 (5.235)***
DPS	0.0448 (3.627)***	0.1871 (4.446)***
FCF	0.4872 (15.737)***	-0.0186 -0.4720
B_SIZE	0.0004 0.7793	0.0106 0.8902
B_ICOM	0.0021 0.8612	0.1967 2.113)**
F_SIZE	0.0020 (0.096)*	0.0010 0.2566
Wald F-test	(116.42)***	(33.68)***
Arellano-Bond test:		
AR(1) (p value)	0.0000	0.0000
AR(2) (p value)	0.7367	0.0485
Hansen test (p value)	0.1519	0.0545
Number of instrument	51	61
Observation	1696	1908

Notes: Robust standard error in parentheses *, **, *** significant at 10%, 5%, and 1% level, except p value for Hansen test and Arellano-Bond test.

namely: **first-** and **second-**order autocorrelation of residuals (AR(1) and AR(2)), Hansen test (*J*-statistic) of overidentifying restriction and Wald test. The results of the specification test show that the Hansen *J*-statistic of overidentifying restriction of the two models has the *p* values of 0.1519 and 0.054 respectively. So that it can be concluded that both model has a valid instruments or overidentifying restriction are satisfied and appropriate model of ROA and TOBINS_Q, this mean the instruments used in the GMM-Difference models are not correlated with the residuals. 285

The result of the Wald test, which is a test of joint significance, show that all coefficient are jointly equal to zero (H_0). Moreover, the Arellano-Bond test suggested that the residual were not affected by the second-order serial autocorrelation for both models, it shows the *p* values of AR(2) are 0.7666 and 0.0485, respectively. This means that we accept the null hypothesis of no **second-**order autocorrelation. 290

The results in Table 3 show that each of the **lagged-**dependent variables ROA(-1) and ROA(-2) and TOBINS_Q (-1) is positive and significantly impact the current accounting and market performance (ROA and TOBINS_Q). This indicates that the dynamic modeling is a right specification for firm performance. The positive and significant lagged firm performance proposes that the data support the lagged effect, and firm performance is dynamic in nature. This implies that firms produced higher return on asset and firm management has the ability to use its assets efficiently and effectively to generate firm profit in previous year. Similarly, the market performance last year provides information to investors of market value of equity to investors, and encourages them to invest in the company. This study is consistent with the earlier study presented by (Zeitun & Saleh, 2015). 295 300

Investment has negative and significant impact on firm performance, suggest that Indonesian public companies with higher percentage of investment have lower firm performance (ROA and TOBINS_Q). The result contradicts the theoretical prediction that investment has a positive impact on firm performance. Additionally, based on the theoretical concept of investment, it suggests that when firms have higher investment or increase growth rate of total assets, it would lead firms to increase firm profitability, in which they would use their assets optimally and take only safe investment. However, in this case, this result indicates that increased investment leads to decreased accounting performance, and this implies a symptom of overinvestment problem. This finding is in line with earlier studies (Ruzita et al., 2010; Sudiyatno & Puspitasari, 2010), who revealed that investment has negative effect on firm performance but insignificant. 305 310

Leverage has negative and significant effects on ROA but positive and significantly affects TOBINS_Q. The negative relationship between leverage and ROA suggests that companies with a higher leverage leads to a lower ROA. This implies that firm has over**leverage, which** in turn affects their performance negatively. This finding supports the theoretical prediction that leverage has negative effect on firm performance. Therefore, profitable firm prefer on internal financing rather than external fund to finance their investment (Myers & Majluf, 1984). This findings are consistent with the past studies such as (Abu-Rub, 2012; Olokoyo, 2013; Ruzita et al., 2010; Shahzad et al., 2015; Vithessonthi & Tongurai, 2015; Zeitun & Saleh, 2015) among others, so that this finding supported by pecking order theory. 315 AQ14

Moreover, dividend policy (DPS) has positive and significant impact on firm performance (ROA and TOBINS_Q) of Indonesian public companies. The data support the hypothesis that **DPS** has positive effects on firm performance. This positive relationship indicates that the higher firm performance encourage firms to payout dividends to its shareholders. Nevertheless, firm with higher **FCF** should pay more dividends to the reduced agency cost as one possible solution to solve it problem of collective actions that tend to lead to undermonitoring of the firm and its management (Easterbrook, 1984; Holder et al., 1998; Mollah et al., 2002). This finding is in line with earlier studies (Imran, 2011; Jensen, 1986; Ruzita et al., 2010). 325 AQ15

In addition, FCF_t has positive and significant effect on ROA but it was insignificant effect on TOBINS_Q. The positive relations suggested that firm with higher FCF_t lead to increase accounting firm performance specifically for large and profitable firms, in which the firm more stable net earnings as well as firm has ability to pay large dividends to shareholders. With respect to corporate governance structure measured by Board Size (B_SIZE) and Board Independent Commissioners (B_ICOM) have positive effect on ROA but insignificant. However, B_ICOM has positive and significant impact on market performance (TOBINS_Q); this implies that the positive role of independent commissioners is also consistent with theoretical prediction. Since corporate governance of Indonesia firms adopted dual board system (BOD and BOC), so that the ratio of independent commissioners has positive sign to market performance, higher number of independent commissioner leads to increase market performance. Firm size has positive and significant relationship on ROA. The positive relation suggested that higher firm size leads to increase market performance. 335 340

6. Conclusion

This study investigates the effect of financial decision behavior on firm performance of 212 Indonesian listed companies using dynamic panel GMM estimation method during the period 2003–2013. The results based on the GMM-difference estimation find that firm performance is dynamic in nature, indicating that the lagged firm performance is significant. This implies that the previous year's firm performance affects the current year performance. The findings of financial decision behavior indicate that financial decision behavior of Indonesian public companies seems to be important factors in determining firm performance, where the investment, capital structure and dividend policy affect financial firm performance significantly. The negative coefficient of investment suggests that the findings are consistent with the theoretical intuition of over-investment, in which managers overinvest lead to decrease firm performance. Similarly to financing decision, Indonesian firms was overleverage, indicates that the negative impact of leverage on ROA due to agency problem between manager and shareholders, thus leads to the decrease firm performance. However, the interesting finding reveals that leverage is positive and significant on market performance (TOBINS_Q). It indicates that debt improves the Indonesian market performance, which may not reflect on their profitability. Moreover, the positive relation between DPS and TOBINS_Q shows that firm payout dividends to shareholders create good signal to the market, which is manager's uses dividend to express their private information about firm prospect of the future earning to the market. In term of theoretical explanation, the impact of financial decision variables of financial firm performance for all the period is consistent with the theory. However, based on the coefficient of financial decision variables, the impact is more on the market performance and less on the accounting performance. 345 350 355 360 365

Funding

The authors received no direct funding for this research.

⁴ Department of Statistics, Universitas Negeri Makassar, Makassar, Indonesia.

Author details

Darmawati Muchtar¹
E-mail: darmawati@unimal.ac.id
Fauzias Mat Nor²
E-mail: fauzias@usim.edu.my
Wahyuddin Albra¹
E-mail: wahyuddin@unimal.ac.id
Muhammad Arifai³
E-mail: arifai_m@yahoo.co.uk
Ansari Saleh Ahmar⁴
E-mail: ansarisaleh@unm.ac.id
ORCID ID: <http://orcid.org/0000-0001-6888-9043>

¹ Faculty of Economy and Business, Malikussaleh University, Lhokseumawe, Aceh, Indonesia.
² Faculty of Economy and Muamalat, Islamic Science University of Malaysia, Nilai, Malaysia.
³ Department of Accountin, Lhokseumawe State of Polytechnic, Aceh, Indonesia.

Citation information

Cite this article as: Dynamic performance of Indonesian public companies: An analysis of financial decision behavior, Darmawati Muchtar, Fauzias Mat Nor, Wahyuddin Albra, Muhammad Arifai & Ansari Saleh Ahmar, *Cogent Economics & Finance* (2018), 00: 1488343.

References

- Abu-Rub, N. (2012). Capital structure and firm performance: Evidence from Palestine stock exchange. *Journal of Money, Investment and Banking*, 23(1), 109–117.
- Alias, N., Rahim, R. A., Nor, F. M., & Yaacob, M. H. (2012). Board structure, capital structure and dividend per share: Do they interact? *International Proceedings of Economics Development and Research*, 57, 148.
- Alias, N., Yaacob, M. H., Rahim, R. A., & Nor, F. M. (2016). Board structure, capital structure and dividend per

AQ16

AQ1

AQ2

- share: Is there interaction effect? *Malaysian Journal of Society and Space*, 12(2), 58–67.
- Amidu, M. (2007). How does dividend policy affect performance of the firm on Ghana stock exchange? *Investment Management and Financial Innovations*, 4(2), 103–112.
- Baltagi, B. (2008). *Econometric analysis of panel data*. Chichester, UK: Wiley.
- Bassey, B. E., & Inah, E. U. (2012). Capital structure, corporate financial performance and shareholders' investment decisions: A survey of selected Nigerian companies. *European Journal of Economics, Finance and Administrative Sciences*, 54, 128–145.
- Berk, A. (2006). Determinants of leverage in Slovenian blue-chip firms and stock performance following substantial debt increases. *Post-Communist Economics*, 18(4), 479–494. doi:10.1080/14631370601008621
- Bhagat, S., & Black, B. S. (2002). The non-correlation between board independence and long-term firm performance. As Published in *Journal of Corporation Law*, 27, 231–273.
- Bhattacharya, S. (1979). Imperfect information, dividend policy, and “the bird in the hand” fallacy.” *The Bell Journal of Economics*, 10(1), 259–270. doi:10.2307/3003330
- Charles, Y., Joseph, C., & Sang, J. (2014). Effects of dividend policy on firm's financial performance: Econometric analysis of listed manufacturing firms in Kenya. *Research Journal of Finance and Accounting*, 5(12).
- Deangelo, H., Deangelo, L., & Stulz, R. M. (2006). Dividend policy and the earned/contributed capital mix: A test of the life-cycle theory. *Journal of Financial Economics*, 81(2), 227–254. doi:10.1016/j.jfineco.2005.07.005
- Del Brio, E., De Miguel, A., & Pindado, J. (2003). Investment and firm value: An analysis using panel data. *Applied Financial Economics*, 13(12), 913–923. doi:10.1080/0960310032000082079
- Djaja, K. (2009). Impact of the global financial and economic crisis on Indonesia. A rapid assessment. In *ILO, Secretary Coordinating Ministry for Economic Affairs, Indonesia*.
- Easterbrook, F. H. (1984). Two agency-cost explanations of dividends. *The American Economic Review*, 74(4), 650–659.
- Fama, E. F. (1978). The effects of a firm's investment and financing decisions on the welfare of its security holders. *The American Economic Review*, 68(3), 272–284.
- Fama, E. F., & Miller, M. H. (1972). *The theory of finance*. New York, NY: Holt, Rinehart, and Winston.
- Fauzias Mat Nor, R. R. A., Azlan, N., & Hasimi, Y. 2011. Corporate finance behavior: Toward key financial performance index (Kfpi) of Malaysian firms. Ministry of Science, Technology and Innovation (MOSTI) Kuala Lumpur.
- Fazzari, S. M., Hubbard, R. G., & Petersen, B. C. (1988). Financing constraints and corporate investment. *Brooking Paper on Economic Activity*, 1988(1), 141–195. doi:10.2307/2534426
- Grazzi, M., Jacoby, N., & Treibich, T. (2011). *Dynamic of investment and firm performance: Comparative evidence in manufacturing industries* DIME Final Conference.
- Guo, Z., & Kga, U. K. (2012). Corporate governance and firm performance of listed firms in Sri Lanka. *Procedia - Social and Behavioral Sciences*, 40, 664–667. doi:10.1016/j.sbspro.2012.03.246
- Halkos, G. E., & Tzeremes, N. G. (2007). Productivity efficiency and firm size: An empirical analysis of foreign owned companies. *International Business Review*, 16(6), 713–731. doi:10.1016/j.ibusrev.2007.06.002
- Hardiyanto, A. T., Achsan, N. A., Sembel, R., & Maulana, T. (2014). The difference of capital structure among industry sectors in the Indonesia stock exchange. *Business and Management Review*, 3(08), 28–35.
- Harris, M., & Raviv, A. (1991). The theory of capital structure. *The Journal of Finance*, 46(1), 297–355. doi:10.1111/j.1540-6261.1991.tb03753.x
- Hashmi, M. S., Mirza, F. M., & Us Sehar, N. (2016). Political regimes, internal funds and investment behaviour: An empirical analysis of manufacturing sector firms in Pakistan. *Pakistan Economic and Social Review*, 54(1), 25.
- Holder, M. E., Langrehr, F. W., & Hexter, J. L. (1998). Dividend policy determinants: An investigation of the influences of stakeholder theory. *Financial Management*, 27, 73–82. doi:10.2307/3666276
- Hubbard, G. (1998). Capital market imperfections and investment. *Journal of Economic Literature*, 35, 193–225.
- Jaffar, R., Mardinah, D., & Ahmad, A. (2013). Corporate governance and voluntary disclosure practices. *Jurnal Pengurusan*, 39(2013), 8392.
- Jensen, M. C. (1986). Agency costs of free cash flow, corporate finance, and takeovers. *The American Economic Review*, 76(2), 323–329.
- Jensen, M. C., & Meckling, W. H. (1976). Theory of the firm: managerial behavior, agency costs and ownership structure. *Journal of Financial Economics*, 3, 305–360. doi:10.1016/0304-405X(76)90026-X
- John, K., & Williams, J. (1985). Dividends, dilution, and taxes: A signalling equilibrium. *The Journal of Finance*, 40(4), 1053–1070. doi:10.1111/j.1540-6261.1985.tb02363.x
- Kaplan, S. N., & Zingales, L. (1997). Do investment-cash flow sensitivities provide useful measures of financing constraints? *The Quarterly Journal of Economics*, 112(1), 169–215. doi:10.1162/003355397555163
- Khan, M. N., Nadeem, B., Islam, F., Salman, M., & Gill, H. M. I. S. (2016). Impact of dividend policy on firm performance: An empirical evidence from Pakistan stock exchange. *American Journal of Economics, Finance and Management*, 2(4), 28–34.
- Kraus, A., & Litztenberger, R. H. (1973). A state preference model of optimal financial leverage. *The Journal of Finance*, 28(4), 911–922. doi:10.1111/j.1540-6261.1973.tb01415.x
- Lintner, J. (1956). Distributions of incomes of corporations among dividends, retained earnings, and taxes. *American Economic Review*, 46, 97–113.
- Loof, H., & Heshmati, A. (2008). Investment and performance of firms: Correlation or causality? *Corporate Ownership & Control*, 6(2), 268–282.
- Magdalena, R. (2012). Influence of corporate governance on capital structure decision: Evidence from Indonesian capital market. *World Review of Business Research*, 2(4), 37–49.
- Margaritis, D., & Psillaki, M. (2010). Capital structure, equity ownership and firm performance. *Journal of Banking & Finance*, 34(3), 621–632. doi:10.1016/j.jbankfin.2009.08.023
- Miller, M. H., & Modigliani, F. (1961). Dividend policy, growth, and the valuation of shares. *The Journal of Business*, 34(4), 411–433. doi:10.1086/jb.1961.34.issue-4
- Miller, M. H., & Rock, K. (1985). Dividend policy under asymmetric information. *The Journal of Finance*, 40, 1031–1051. doi:10.1111/j.1540-6261.1985.tb02362.x

- AQ21 Modigliani, F., & Miller, M. (1963, June). Corporate income taxes and the cost of capital: A correction. *American Economic Review*, 53(June), 433–443.
- Modigliani, F., & Miller, M. H. (1958). The cost of capital, corporation finance and the theory of investment. *The American Economic Review*, 48(3), 261–297.
- Mollah, S., Keasey, K., & Short, H. (2002). The influence of agency costs on dividend policy in an emerging market: Evidence from the Dhaka stock exchange. *Working Paper* 10.1044/1059-0889(2002/er01)
- Murekefu, T. M., & Ouma, O. P. (2012). The relationship between dividend payout and firm performance: A study of listed companies in Kenya. *European Scientific Journal*, 8(9). ISSN: 1857 – 7881.
- AQ20 Myers, S. C. (1977). Determinants of corporate borrowing. *Journal of Financial Economics*, 5(2), 147–175. doi:10.1016/0304-405X(77)90015-0
- Myers, S. C., & Majluf, N. S. (1984). Corporate financing and investment decisions when firms have information that investors do not have. *Journal of Financial Economics*, 13(2), 187–221. doi:10.1016/0304-405X(84)90023-0
- AQ22 Nikolaus, V. (2015, July 2). *Determinants of Firm financial performance in Indonesia and the Netherlands: A comparison* (5th IBA Bachelor Thesis Conference). Anjuran Enschede, The Netherlands.
- Onaolapo, A. A., & Kajola, S. O. (2010). Capital structure and firm performance: Evidence from Nigeria. *European Journal of Economics, Finance and Administrative Sciences*, 25, 70–82.
- Riachi, I., & Schwienbacher, A. (2015). Investment, firm performance and securitization: Evidence from industrial companies. *Finance Research Letters*, 13, 17–28. doi:10.1016/j.frl.2015.03.007
- Rozeff, M. S. (1982). Growth, beta and agency cost of determinants of dividend payout ratio. *Journal of Financial Research*, 5(3), 249–259. doi:10.1111/j.1475-6803.1982.tb00299.x
- Ruzita, A. R., Hasimi, M., Yaacob, N. A., & Fauzias, M. N. (2010). Investment, board governance and firm value: A panel data analysis. *International Review of Business Research Papers*, 6(5), 293–302.
- Saeedi, A., & Mahmoodi, I. (2011). Capital structure and firm performance: Evidence from Iranian Companies. *International Research Journal of Finance and Economics*, 70(11), 20–29.
- AQ23 San, O. T., & Heng, T. B. (2011). Capital structure and corporate performance of Malaysian construction sector. *International Journal of Humanities and Social Science*, 1(2), 28–36.
- Scott, J. (1977). Bankruptcy, secured debt, and optimal capital structure. *The Journal of Finance*, 32, 1–19. doi:10.1111/j.1540-6261.1977.tb03237.x
- Shahzad, S. J. H., Ali, P., Ahmad, T., & Ali, S. (2015). Financial leverage and corporate performance: Does financial crisis owe an explanation? *Pakistan Journal of Statistics and Operation Research*, 11(1), 67–90. doi:10.18187/pjsor.v11i1.781
- Stulz, R. M. (2000). Merton miller and modern finance. *Financial Management*, 29, 119–131. doi:10.2307/3666371
- Sudiyatno, B., & Puspitasari, E. (2010). Pengaruh Kebijakan Perusahaan Terhadap Nilai Perusahaan Dengan Kinerja Perusahaan Sebagai Variabel Intervening (Studi Pada Perusahaan Manufaktur Di Bursa Efek Indonesia). *Dinamika Keuangan Dan Perbankan*, 2(1), 1–22.
- Sudiyatno, B., Puspitasari, E., & Kartika, A. (2012). The company's policy, firm performance, and firm value: An empirical research on Indonesia stock exchange. *American International Journal of Contemporary Research*, 2(12), 30–40.
- Suta, I. P. G. A. (2006). Market performance of Indonesia public companies: An analysis of corporate reputation. *Book Yayasan Sad Satria Bakti - Jakarta, Indonesia*.
- Tan, J., & Wang, L. (2010). Reribility-efficiency tradeoff and performance implications among Chinese SOEs. *Journal of Business Research*, 63(4), 356–362. doi:10.1016/j.jbusres.2009.04.016
- Tobin, J. (1969). A general equilibrium approach to monetary theory. *Journal of Money, Credit and Banking*, 1(1), 15–29. doi:10.2307/1991374
- Uwuigbe, U., Jafaru, J., & Ajayi, A. (2012). Dividend policy and firm performance: A study of listed firms in Nigeria. *Accounting and Management Information Systems*, 11(3), 442.
- Velnampy, T., Nimalthasan, M. P., & Kalaiarasi, M. K. (2014). Dividend policy and firm performance: Evidence from the manufacturing companies listed on the Colombo stock exchange. *Global Journal of Management and Business Research*, 14(6).
- Vithessonthi, C., & Tongurai, J. (2015). The effect of firm size on the leverage–performance relationship during the financial crisis of 2007–2009. *Journal of Multinational Financial Management*, 29, 1–29. doi:10.1016/j.mulfin.2014.11.001
- Wang, G. Y. (2010). The impacts of free cash flows and agency costs on firm performance. *Service Science & Management*, 3(4), 408–418. doi:10.4236/jssm.2010.34047
- Wardhana, L. I., Tandellilin, E., Wayan Nuka Lantara, I., & Junarsin, E. (2014). *Dividend policy in Indonesia: A life-cycle explanation*. Asian Finance Association (AsianFA) 2014 Conference Paper. Anjuran. Retrieved from <https://papers.ssrn.com>
- Wintoki, M. B., Linck, J. S., & Netter, J. M. (2012). Endogeneity and the dynamics of internal corporate governance. *Journal of Financial Economics*, 105(3), 581–606. doi:10.1016/j.jfineco.2012.03.005
- Ye, B., & Yuan, J. (2008). Firm value, managerial confidence, and investments: The case of China. *Journal of Leadership Studies*, 2(3), 26–36. doi:10.1002/jls.v2:3
- Yu, L., & Li, L. (2011). *Corporate governance, free cash flow and over-investment*. Business Management and Electronic Information (BMEI), 2011 International Conference on, hlm (pp.713–717).
- Zabri, S. M., Ahmad, K., & Wah, K. K. (2016). Corporate governance practices and firm performance: Evidence from top 100 public listed companies in Malaysia. *Procedia Economics and Finance*, 35, 287–296. doi:10.1016/S2212-5671(16)00036-8
- Zeitun, R. (2014). corporate governance, capital structure and corporate performance: Evidence from GCC countries. *Review of Middle Eastern Economics and Finance*, 10(1), 75–96.
- Zeitun, R., & G. Tian, G. (2007). Capital structure and corporate performance: Evidence from Jordan. *Australasian Accounting Business and Finance Journal*, 1(4), 40.
- Zeitun, R., & Saleh, A. S. (2015). Dynamic performance, financial leverage and financial crisis: Evidence from GCC countries. *EuroMed Journal of Business*, 10(2), 147–162. doi:10.1108/EMJB-08-2014-0022



© 2018 The Author(s). This open access article is distributed under a Creative Commons Attribution (CC-BY) 4.0 license.

You are free to:

Share — copy and redistribute the material in any medium or format.

Adapt — remix, transform, and build upon the material for any purpose, even commercially.

The licensor cannot revoke these freedoms as long as you follow the license terms.

Under the following terms:

Attribution — You must give appropriate credit, provide a link to the license, and indicate if changes were made.

You may do so in any reasonable manner, but not in any way that suggests the licensor endorses you or your use.

No additional restrictions

You may not apply legal terms or technological measures that legally restrict others from doing anything the license permits.



***Cogent Economics & Finance* (ISSN: 2332-2039) is published by Cogent OA, part of Taylor & Francis Group.**

Publishing with Cogent OA ensures:

- Immediate, universal access to your article on publication
- High visibility and discoverability via the Cogent OA website as well as Taylor & Francis Online
- Download and citation statistics for your article
- Rapid online publication
- Input from, and dialog with, expert editors and editorial boards
- Retention of full copyright of your article
- Guaranteed legacy preservation of your article
- Discounts and waivers for authors in developing regions

Submit your manuscript to a Cogent OA journal at www.CogentOA.com



REVIEW COMMENTS

General Comment

The paper is an interesting one which has the potential to contribute to the stock of knowledge as the authors used a much robust methodology.

The literature review also included an up to date literature. However, the authors could have presented a summary after the literature review of the gap identified in which the present study could fill. Also the authors should indicate the conceptual framework of the study linking the study variables.

Finally, the standard of English of the paper must be improved. The grammar was not good. The authors must ensure that the work is proof read before being submitted.

The specific comments are outlined below. The page numbers refer to the pdf pagination as appeared on the number counter.

ABSTRACT

The abstract is well written but must be within the 100 -200 words band. The words are 219.

Line 3: The results show that firm performance is dynamic (not are)

Line 4: ... nature, which indicates that

1 INTRODUCTION

Pdf Page 2:

The second sentence in line 2 to line 5 must edited for clarity of expression. Also, lines 7 to line 13 should be edited for clarity.

Line 6: (Tan & Wang, 2010).

Page 3

Lines 12 and 13 of pdf page 3...the issue arise for Indonesian listed firm, which is investment has negative effect on firm performance but insignificant... must edited for clarity

Line 20 Therefore, financial leverage and firm performance have (not has) negative relationship

line 22 (Jensen & Meckling 1976; Myers 1977). However, some researchers dispute that financial leverage and firm performance have (not has) positive relation.

Line 25 ... was 56 percent by sector. You should be specific.

Line 35... the propensity of the firm to pay dividend has...

Line 41 This study apply the dynamic panel Generalized Method of Moment (GMM) estimator to respond the endogeneity issue in corporate finance behavior, which is the dynamic panel GMM estimator more advanced estimators rather than the static model estimation (OLS, fixed effect and random effect model). This should be edited for clarity.

... Therefore, to provide additional evidence...

.... The rest of this paper is organized as follows. In (this should be deleted) to read as section 2 reviews the literature

Page 4.
Section 3 and 4 describe

2 LITERATURE REVIEW

Investment and Firm Performance

Line 3: ... The Tobin's q becomes

Line 8: For instance

...Although there is a limited number of studies in the....

...panel data, the interestingly, serve no purpose and should be deleted.

Leverage and Firm Performance

Line 7: The pecking

Line 16: ...Other recent evidence examined by Olokoyo (2013) found that TDTA significantly (should be deleted) has positive and significant effect

The hypotheses tested in the study must be stated as indicated by the authors.

3 METHODOLOGY

Page 5: line 3 and line 4 include (not includes). ...and other financial data used in this study

is it Tobin's Q or Tobins Q. You must be consistent.

Last paragraph page 5:

... (B_ICOM) and sales are used as control variables. The ... (EBIT and depreciation) minus the total of...

Page 6

Equation 2 and 3 must be specified well especially coefficients of B_ICOM_{it} and F_SIZE_{it} should read δ_6 and δ_7 respectively.

4 Discussion

Descriptive statistics

Page 6

Line 2: The Table should be numbered as Table 1 and not Table 5.1.

Line 3: ... the results show ...

Page 7

Table1 should include information on skewness, kurtosis as well as Jarque- Bera statistics.

...board size and firm size but investment, leverage and independent commissioner's show insignificant correlation.

... There are four diagnostic tests that should be addressed in this study to evaluate the ... Moreover, the Arellano-Bond test suggested that the residual were not affected by the second-order serial autocorrelation for both models, it shows the p -values of AR(2) are 0.7666 and...

Page 9

Last paragraph before the conclusion should read

... In addition, free cash flow have positive and significant effect on ROA but it...

5. CONCLUSION

Page 9

Line 6: ... indicate

6. Citation and reference list

Some of the citations were not included in the reference list. The authors should include them as indicated below.

Del Brio et al. (2003)

Zabri et al. 2016)

PAPER CORRECTION LIST

Dynamic Performance of Indonesian Public Companies: An Analysis of Financial Decision Behavior

Reviewer:

	Comments	Action Taken / Justification	Page number
1.	<p>General Comment</p> <p>The paper is an interesting one which has the potential to contribute to the stock of knowledge as the authors used a much robust methodology.</p> <p>The literature review also included an up to date literature. However, the authors could have presented a summary after the literature review of the gap identified in which the present study could fill.</p> <p>Also the authors should indicate the conceptual framework of the study linking the study variables.</p> <p>Finally, the standard of English of the paper must be improved. The grammar was not good. The authors must ensure that the work is proof read before being submitted.</p>	<p>First, I would like to thank you for any comments and suggestion of this paper. Overall, I have been revised all of the comments as suggested.</p> <p>Thank you.</p> <p>Have been addressed in 5th paragraph of introduction. Accordingly.....</p> <p>Have been presented in section.3 conceptual framework.</p> <p>I did proof read. However, if not satisfy I will sent to another editor.</p> <p>Overall, the grammatical error as suggested has been corrected.</p>	<p style="text-align: center;">p.2</p> <p style="text-align: center;">p.5</p>

	Comments	Action Taken / Justification	Page number
	<p>The specific comments are outlined below. The page numbers refer to the pdf pagination as appeared on the number counter.</p> <p>ABSTRACT</p> <p>The abstract is well written but must be within the 100-200 words band. The words are 219.</p> <p>Line 3: The results show that firm performance <u>is</u> dynamic (not are)</p> <p>Line 4: ... nature, <u>which</u> indicates that</p>	<p>Have been changed.</p> <p>Corrected done</p>	<p>p.1</p>
	<p>1.INTRODUCTION</p> <p>Pdf Page 2:</p> <p>The second sentence in line 2 to line 5 must edited for clarity of expression. Also, lines 7 to line 13 should be edited for clarity. Line 6: (Tan & Wang, 2010).</p> <p>Page 3</p> <p>Lines 12 and 13 of pdf page 3...the issue arise for Indonesian listed firm, which is investment has negative effect on firm performance but insignificant... must edited for clarity.</p> <p>Line 20 Therefore, financial leverage and firm performance <u>have</u> (not has) negative relationship line 22 (Jensen & Meckling 1976; Myers 1977). However, some researchers dispute that financial</p>	<p>Have been edited. See in 1st paragraph line 2 to line 5.</p> <p>Have been revised, and add some justification. See lines 7 to lines 13.</p> <p>Have been revised, now to be in 13 to 14.</p> <p>Done in line 21.</p> <p>Done in line 23.</p>	<p>p.1</p> <p>p.1</p> <p>p.2</p> <p>p.2</p> <p>p.2</p>

	Comments	Action Taken / Justification	Page number
	<p>leverage and firm performance have (not has) positive relation. Line 25 ... was 56 percent <u>by sector</u>. You should be specific.</p> <p>Line 35... the propensity of the firm <u>to</u> pay dividend has...</p> <p>Line 41 <u>This study apply the dynamic panel Generalized Method of Moment (GMM) estimator to respond the endogeneity issue in corporate finance behavior, which is the dynamic panel GMM estimator more advanced estimators rather than the static model estimation (OLS, fixed effect and random effect model)</u>. This should be edited for clarity.</p> <p>... Therefore, to provide additional evidence... The rest of this paper is organized as follows. <u>In</u> (this should be deleted) to read as section 2 reviews the literature Page 4. Section 3 and 4 <u>describe</u></p>	<p>Revised done, now in lines 26 to 27.</p> <p>Done in line 37.</p> <p>Have been revised . See line 50 1st paragraph</p> <p>Sorry Prof, a bit confused for this point. Please correct it if still wrong words. Thank you.</p> <p>Done.</p>	<p>p.2</p> <p>p.3</p>
	<p>2. LITERATURE REVIEW</p> <p>Investment and Firm Performance Line 3: ... The Tobin's q <u>becomes</u> Line 8: For <u>instance</u></p>	<p>Done. Restructuring the sentence in lines 9 to 12.</p>	<p>p.3</p>

	Comments	Action Taken / Justification	Page number
	<p>....Although there is a limited number of <u>studies</u> in the.... ...panel data, <u>the interestingly</u>, serve no purpose and should be deleted.</p> <p>Leverage and Firm Performance Line 7: The <u>pecking</u> Line 16: ...<u>Other</u> recent evidence examined by Olokoyo (2013) found that TDTA <u>significantly (should be deleted)</u> has positive and significant effect</p> <p>The hypotheses tested in the study must be stated as indicated by the authors.</p>	<p>Done.</p> <p>Have been revised and paraphrasing/ restructure the sentence.</p> <p>Corrected done in line 13.</p> <p>This section have been revised, there is additional justification of the theories. See lines 1 to 7.</p> <p>The hypotheses tested have presented for each relationship.</p>	<p>p.4</p> <p>p.4-5</p>
	<p>METHODOLOGY Page 5: line 3 and line 4 include (not includes). ...and <u>other</u> financial data <u>used</u> in this study is it Tobin's Q or Tobins Q. You must be consistent. Last paragraph page 5: ... (B_ICOM) and sales are <u>used</u> as control variables. The ... (EBIT and depreciation) <u>minus</u> the total of...</p> <p>Page 6 Equation 2 and 3 must be specified well especially coefficients of B_ICOM_{it} and F_SIZE_{it} should read δ_6 and δ_7 respectively.</p>	<p>Correction done in page 6.</p> <p>Done.</p> <p>Correction done in page 7.</p>	<p>p.6</p> <p>p.7</p>

	Comments	Action Taken / Justification	Page number
	<p>Discussion</p> <p>Descriptive statistics Page 6 Line 2: The Table should be numbered as Table 1 and not Table 5.1. Line 3: ... the results <u>show</u> ...</p> <p>Page 7 Table1 should include information on skewness, kurtosis as well as Jarque- Bera statistics.</p> <p>...board size and firm size but investment, leverage and independent commissioner's <u>show</u> insignificant correlation. ... There are four diagnostic <u>tests that</u> should be addressed in this study to <u>evaluate</u> the ... Moreover, the Arellano-Bond test suggested that the residual were not <u>affected</u> by the second-order serial autocorrelation for both models, <u>it shows</u> the <i>p</i>-values of AR(2) are 0.7666 and...</p> <p>Page 9 Last paragraph before the conclusion should read ... In addition, free cash flow have positive and <u>significant effect</u> on ROA but it...</p>	<p>Corrected in line 2.</p> <p>Done. See Table 1.</p> <p>All this grammatical error have been corrected.</p> <p>Done.</p>	<p>p.8</p> <p>p.8</p> <p>p.9</p>

	Comments	Action Taken / Justification	Page number
	<p>CONCLUSION</p> <p>Page 9 Line 6: ... <u>indicate</u></p>	<p>Done.</p> <p>There are additional statements in conclusion, lines 18 to 21.</p>	<p>p.11</p>
	<p>Citation and reference list Some of the citations were not included in the reference list. The authors should include them as indicated below. Del Brio et al. (2003) Zabri et al. 2016)</p>	<p>Now already available in references.</p> <p>Thank you for good comments. If there is still find not clarity, please let me know. I try to revise again.</p>	<p>P12 & 17</p>

Re: OAEF 1488343 #TrackingId:1346440

OAEF-production@journals.tandf.co.uk <OAEF-production@journals.tandf.co.uk>
To: darmawati@unimal.ac.id
Cc: vicky.truter@tandf.co.za

Tue, Jan 21, 2020 at 7:43 PM

Dear Darmawati Muchtar,

Apologies for the delay in responding your email.

I am Dhivya Bharathi. P, handling the journal since last 6 months. We are very grateful to receive your papers for this journal.

I request you to submit your papers directly to peer review team, we can process the article once they have validated and approved your article.

Herewith I have copied the journal portfolio manger for your reference.

Best wishes,

Dhivya

Cogent OA, Taylor & Francis Group
[2&4 Park Square, Milton Park](#), Abingdon
Oxfordshire, OX14 4RN
UNITED KINGDOM
www.CogentOA.com

Cogent Economics & Finance

From: darmawati@unimal.ac.id
Sent: 11-01-2020 01.47 PM
To: OAEF-production@journals.tandf.co.uk, darmawati@unimal.ac.id
Cc:
Subject: Re: OAEF 1488343

Dear Mr. Balaji Shanmuga,

Hope you are doing well, still remember me? I'm Darmawati Muchtar one of the authors has been published online:
<http://dx.doi.org/10.1080/23322039.2018.1488343>.

Anyway, I would like to inform you that, I have some papers get ready to send to any journal. I was thinking of asking you if possible and available slot that will be published within this year (February, April or other series).

Kindly find the attached file. I want the paper paublish at Econoimic Journal "political economic". Highly apprecate if you cal help me.

Thank you for your help and attantioin.

Best regards,

Darmawati Muchtar
Senior Lecturer
FEB UNIMAL-Aceh
Indonesia

On Fri, Aug 3, 2018 at 2:27 PM <OAEF-production@journals.tandf.co.uk> wrote:

Dear Darmawati Muchtar,

Thanks for your patience!

Please note that we won't be able to provide a TOC (Table of contents) file as the journal is BIO (Online only), but you could print this page:

<https://www.cogentoa.com/journal/economics-and-finance/articles?volume=6>

Also, I have attached the cover of journal for you.

I hope this helps.

Best wishes,

Balaji

Cogent OA, Taylor & Francis Group
2&4 Park Square, Milton Park, Abingdon
Oxfordshire, OX14 4RN
UNITED KINGDOM
www.CogentOA.com

To successfully download attachments you may need to switch off any pop up blockers that your web browser is running. Your browser may present you with the option to 'allow once', or you can find the option to permanently switch off pop up blockers under your browser's Settings menu. Attachments may not open up straight away when you click on the link as they are first being downloaded from the cloud. Please check for a downloaded document icon at the bottom of your screen (in Chrome, IE or Firefox) or in your downloads folder in Safari.

Cogent Economics

From: balaji.shanmugam@integra.co.in
Sent: 02-08-2018 08:57 AM
To: balaji.shanmugam@integra.co.in, darmawati@unimal.ac.id
Cc:
Subject: Re: OAEF 1488343 - Proof corrections required

Dear Darmawati Muchtar,

Thanks for your email.

I'll check and get back to you with my response at the earliest.

Best wishes,

Balaji

Cogent OA, Taylor & Francis Group
2&4 Park Square, Milton Park, Abingdon
Oxfordshire, OX14 4RN
UNITED KINGDOM
www.CogentOA.com

To successfully download attachments you may need to switch off any pop up blockers that your web browser is running. Your browser may present you with the option to 'allow once', or you can find the option to permanently switch off pop up blockers under your browser's Settings menu. Attachments may not open up straight away when you click on the link as they are first being downloaded from the cloud. Please check for a downloaded document icon at the bottom of your screen (in Chrome, IE or Firefox) or in your downloads folder in Safari.

From: darmawati@unimal.ac.id
Sent: 01-08-2018 10.33 AM
To: darmawati@unimal.ac.id
Cc:
Subject: Re: OAEF 1488343 - Proof corrections required

Dear Sir,

Thank you very much for published my paper on 18th July 2018. Can I have cover and contain of the journal? I mean that I series of juornal, I need it for binding hard copy. We should submit to my Uni with complite cover and list of content of the papers have been published.

Thank for your help.

Author,

Darmawati Muchtar

Darmawa

On Wed, Jul 11, 2018, 1:59 PM <OAEF-production@journals.tandf.co.uk> wrote:

Dear Ansari Saleh Ahmar,

I hope you are well.

I am writing because we have not yet received the proof corrections for your paper entitled 'Dynamic Performance of Indonesian Public Companies: An Analysis of Financial Decision Behavior', which were due to be returned to us by 28th June.

I have attached the typeset PDF proof of your article to this email for your convenience. Please can you answer the Author Queries (AQs) raised by our copy-editing team, and also let us know of any additional amendments or corrections that you want to make.

Please then return the file directly to me and I will pass it on to the typesetter. You can mark up the attached PDF, or list your corrections in a Word document, or email.

Please can you return your corrections to me by tomorrow (Thursday 12th July).

I'm copying in your co-authors in case you are unavailable at present.

If you have any further queries, please just let me know.

Best wishes,

Balaji

Cogent OA, Taylor & Francis Group
2&4 Park Square, Milton Park, Abingdon
Oxfordshire, OX14 4RN

UNITED KINGDOM
www.CogentOA.com

To successfully download attachments you may need to switch off any pop up blockers that your web browser is running. Your browser may present you with the option to 'allow once', or you can find the option to permanently switch off pop up blockers under your browser's Settings menu. Attachments may not open up straight away when you click on the link as they are first being downloaded from the cloud. Please check for a downloaded document icon at the bottom of your screen (in Chrome, IE or Firefox) or in your downloads folder in Safari.

Cogent Economics

From: cogentoa.iproof@integra.co.in
Sent: 26-06-2018 07:41
To: cogentoa.iproof@integra.co.in, ansarisaleh@unm.ac.id
Cc:
Subject: Your article proofs for review (Manuscript ID: OAEF 1488343)

Manuscript Title: OAEF_A_1488343
Manuscript DOI: 10.1080/23322039.2018.1488343
Journal: Cogent Economics & Finance

Dear Ansari Saleh Ahmar,

I am pleased to inform you that your proofs are now available for review using the Cogent OA online proofing system:

<https://www.icorrectproof.com/Home/Integra?bpH59qSn1W/hy66RE4YUuboEBPar714ZGhIsmqhXLZULzA+IzvRUsj72yHese15W/3CljXCq3MPjiiMlvC7s3X4dmz4vowZRSANfGfXGdijsAetfUQGcw==>

Log-in email address: ansarisaleh@unm.ac.id

Please submit your corrections by 28 June 2018, to avoid delay to publication.

Please ensure that you answer all Author Queries. Typographical and essential corrections can also be made at this point.

Your article should be published online within 5–7 working days of us receiving your corrections, as long as you have returned your Author Publishing Agreement.

The DOI of your article is: 10.1080/23322039.2018.1488343. and your article will be available at the following permanent link as soon as it has published online: <http://dx.doi.org/10.1080/23322039.2018.1488343>.

If you have any questions, please contact me using the details below and I will be pleased to assist.

Thank you,

Balaji Shanmugam

On behalf of the OAEF production team
Cogent OA
2-4 Park Square, Milton Park, Abingdon, Oxfordshire, OX14 4RN, United Kingdom
Email: OAEF-production@journals.tandf.co.uk

This email and any accompanying attachments is for the sole use of the intended recipient(s) and may contain confidential and privileged information. Any unauthorized review, use, disclosure, distribution, or copying is strictly prohibited. If you are not the intended recipient of this communication or received the email by mistake, please notify the sender and destroy all copies. Integra Software Services Pvt Ltd. reserves the right, subject to applicable local law, to monitor and review the content of any electronic message or information sent to or from its company allotted employee email address/ID without informing the sender or recipient of the message.

