

TEE 843 – Sistem Telekomunikasi

4. Sinyal Komunikasi



universitas
MALIKUSSALEH

Muhammad Daud Nurdin

mdaud@unimal.ac.id, syechdaud@yahoo.com

**Jurusan Teknik Elektro FT-Unimal
Lhokseumawe, 2018**



Signals in Communications

- Introduction
- Basics of Signal
- Characteristics of analog voice channels
- Fundamental differences between analog and digital signals
- Analog-to-digital conversion
- Signal power



Pendahuluan

- Services that the telecommunications networks provide have different characteristics. Required characteristics depend on the applications we use. To meet these different requirements, many different network technologies that are optimized for each type of service are in use.
- To understand the present structure of the telecommunications network, we have to understand what types of signals are transmitted through the telecommunications network and their requirements.
- In this chapter we look at the basics of signal, characteristics of analog voice channels, fundamental differences between analog and digital signals, analog-to-digital conversion, power of signal, and a logarithmic measure of signal level (the decibel).



Jenis-jenis Informasi

- **Jaringan digital modern** mentransmisikan informasi digital secara **transparan**, yaitu jaringan tdk perlu tahu apa jenis informasi yg dikandung oleh data.
- Adapun **informasi** yg ditransmisikan melalui jaringan ini dpt berupa:
 - *Speech/voice (telephony; fixed or mobile/celular);*
 - *Text (electronic mail or short text messaging);*
 - *Printed pages or still picture (facsimile or multimedia messaging);*
 - *Moving images (television or video);*
 - *Music;*
 - *All types of computer information such as program files.*



Signals in Communications

- Introduction
- **Basics of Signal**
- Characteristics of analog voice channels
- Fundamental differences between analog and digital signals
- Analog-to-digital conversion
- Signal power



Basics of Signal (1)

- **Sinyal (*signal*)** adalah besaran fisis yang berubah menurut waktu, ruang, atau variabel-variabel bebas (independen) lainnya. Contoh sinyal: sinyal suara, sinyal gambar, dll.
- Secara matematis, **sinyal** adalah fungsi dari satu atau lebih variabel independen. Yang paling umum, sinyal adalah fungsi dari waktu.
- Untuk keperluan **komunikasi (elektronik)**, sinyal/besaran fisis harus diubah menjadi **sinyal listrik**.
- Terkadang perlu diubah lagi menjadi **sinyal elektromagnetik** ataupun **sinyal optik**.

Basics of Signal (2)

- Untuk mengubah sinyal suara menjadi sinyal elektrik atau sebaliknya digunakan **transducer** (yaitu alat utk mengubah energi dari suatu bentuk ke bentuk lain).

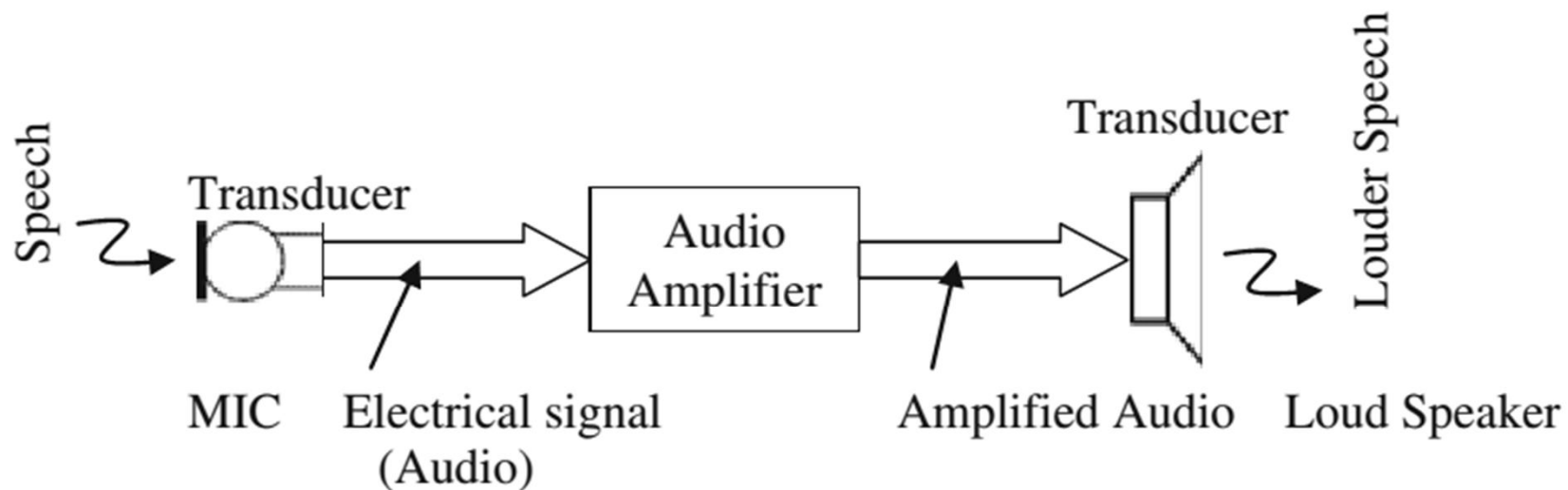

Speech signal amplification with the help of transducers and electrical amplifier

Contoh Sinyal Suara

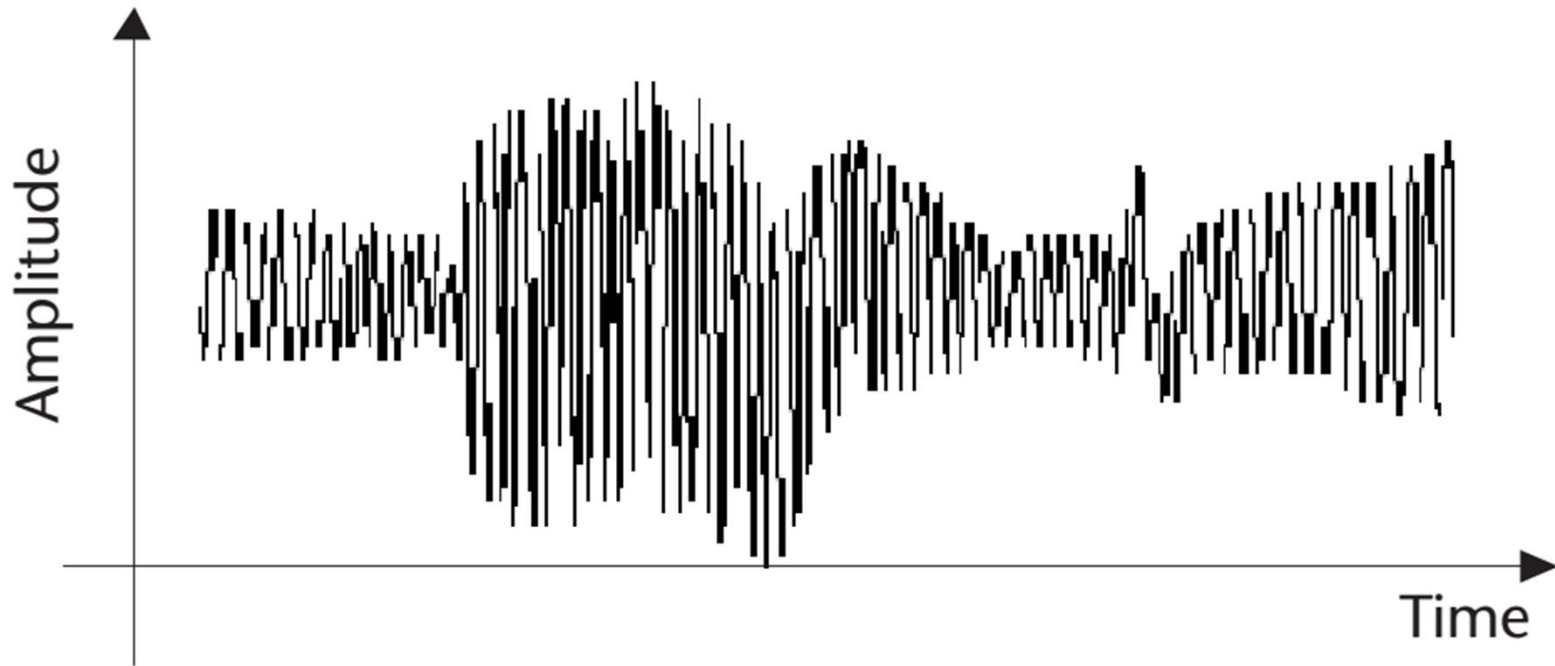



Parameter Dasar

- Amplituda (*Amplitude*), A
- Frekuensi (*Frequency*), f atau ω
- Fase (*Phase*), ϕ

Contoh-contoh sinyal sinusoidal berikut ini menggunakan persamaan umum:

$$x(t) = A \sin (2\pi ft + \phi)$$

Amplituda (*Amplitude*)

$A = 1$

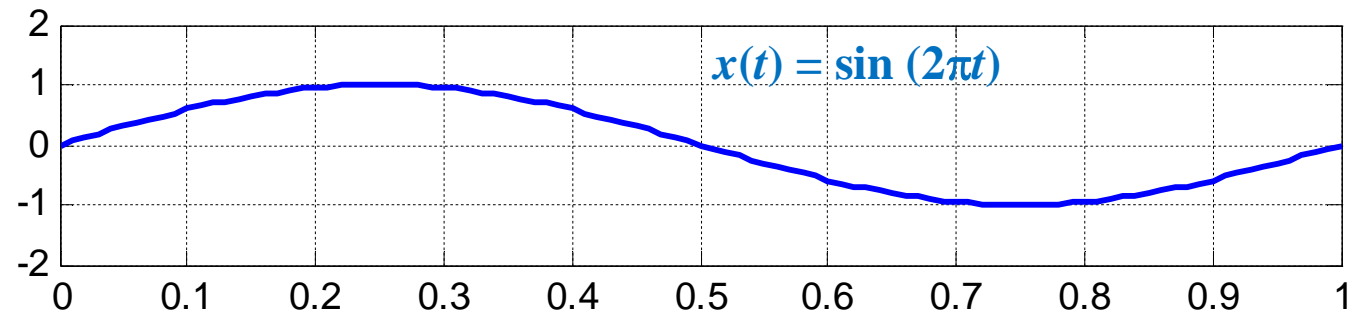

$A = 2$

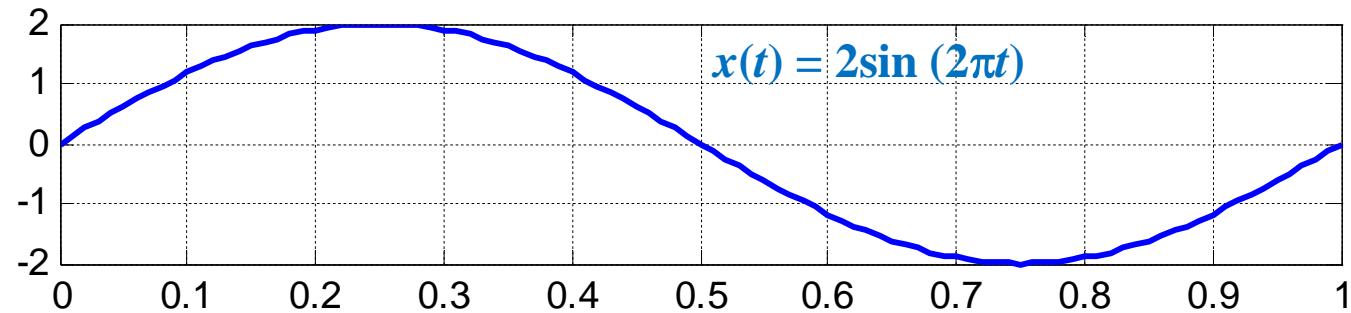

$A = 0,5$

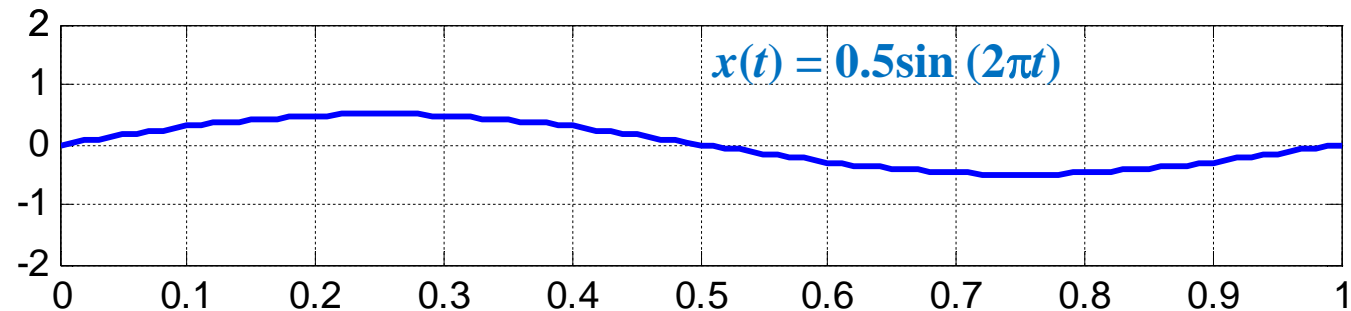

Frekuensi (*Frequency*)

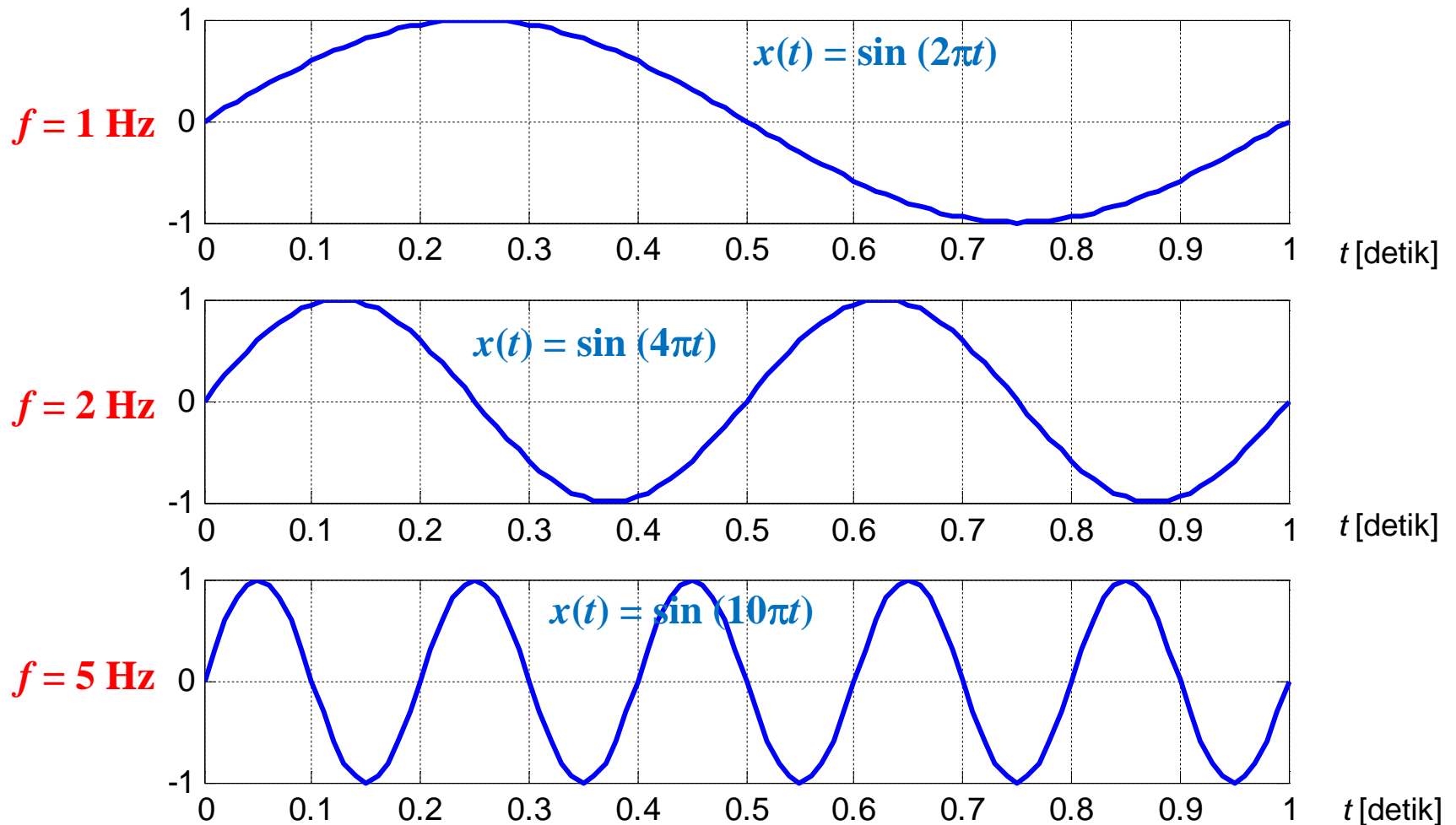

Fase (*Phase*)

$\phi = 0$ radian
 $= 0^\circ$

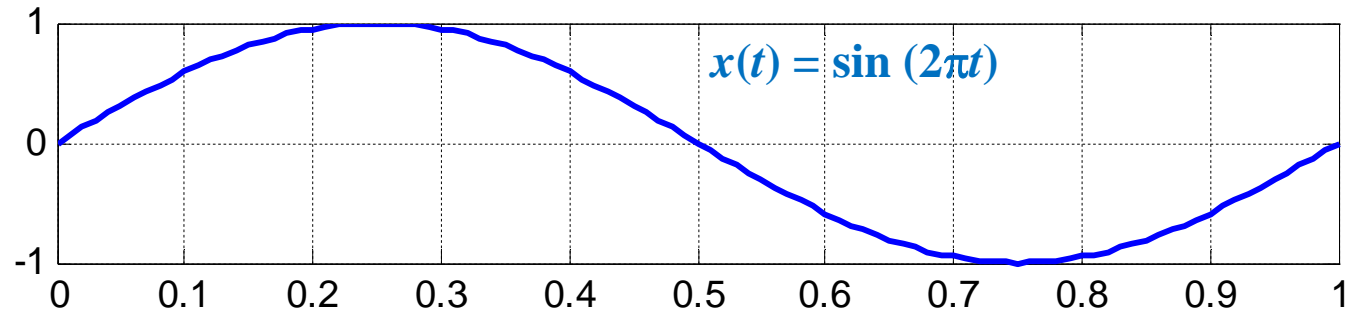

$\phi = -\pi/4$ rad
 $= -45^\circ$

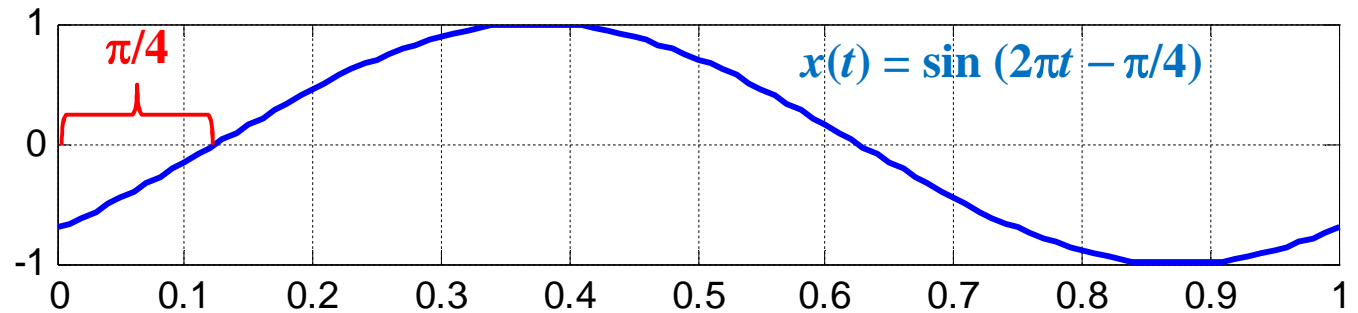

$\phi = -\pi/2$ rad
 $= -90^\circ$

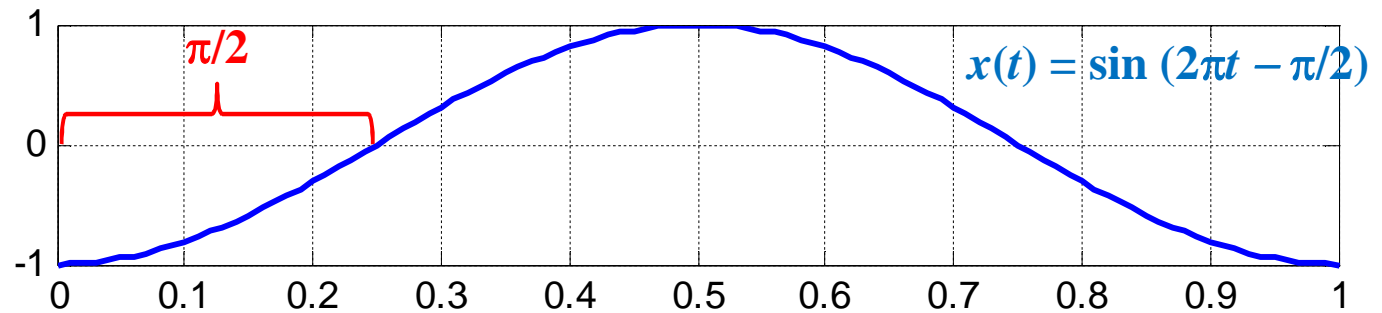

Gelombang dan Spektrum

- **Sinyal komunikasi** merupakan besaran yang selalu berubah terhadap waktu.
- Setiap sinyal dpt dinyatakan dlm **domain waktu** (*time domain*) maupun dlm **domain frekuensi** (*frequency domain*).
- Ekspresi sinyal di dalam **domain waktu** disebut **gelombang** atau **bentuk gelombang** (*waveform*). Utk melihat sinyal dlm domain waktu digunakan **oscilloscope**.
- Ekspresi sinyal di dalam **domain frekuensi** disebut **spektrum** (*spectrum*). Utk melihat sinyal dlm domain frekuensi digunakan **spectrum analyzer**.
- Sinyal di dalam domain waktu merupakan penjumlahan dari komponen-komponen spektrum sinusoidal.

Gelombang dan Spektrum (2)

- Untuk menghubungkan sinyal dalam domain waktu dengan sinyal di dalam domain frekuensi digunakan **Analisis Fourier**.
 - **Deret Fourier** utk sinyal periodik
 - **Transformasi Fourier** utk sinyal non-periodik (dan bisa juga utk sinyal periodik)
- Spektrum sinyal:
 - Sinyal periodik → spektrum diskrit
 - Sinyal non-periodik → spektrum kontinu
- **Bandwidth** adalah **lebar pita** frekuensi yg terkandung dlm suatu sinyal, yaitu frekuensi tertinggi dikurang frekuensi terendah.

$$BW = f_{\text{high}} - f_{\text{low}}$$

Gelombang dan Spektrum (3)

Waveform
(time domain)

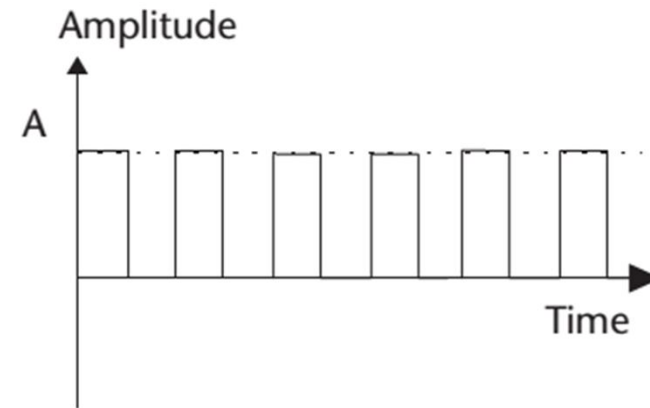
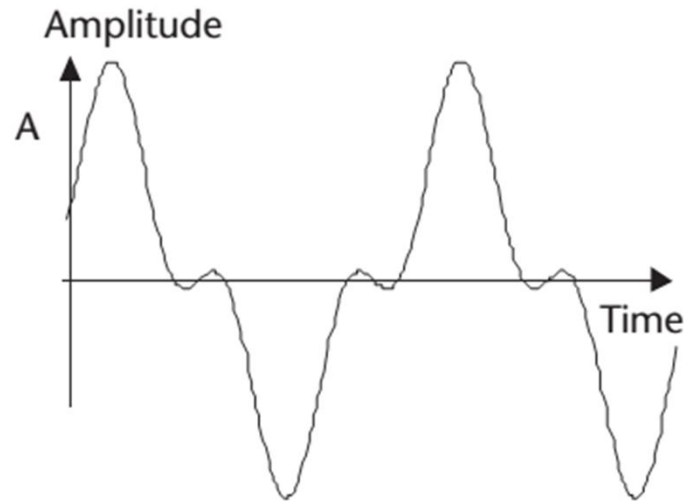

Spectrum
(frequency domain)

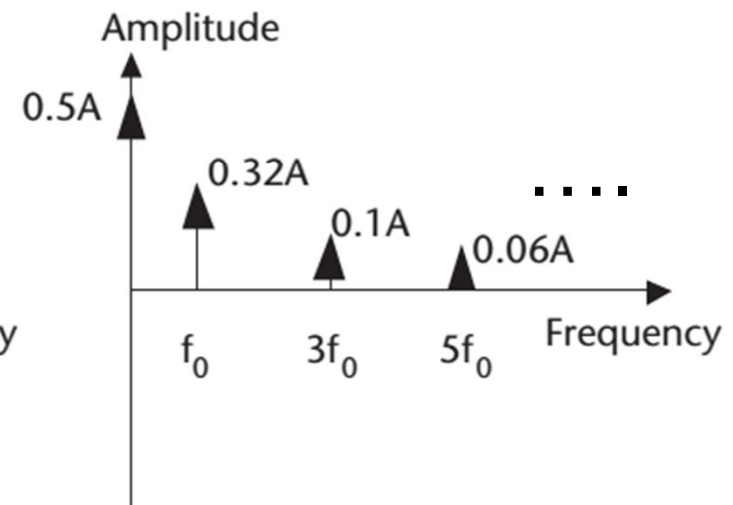
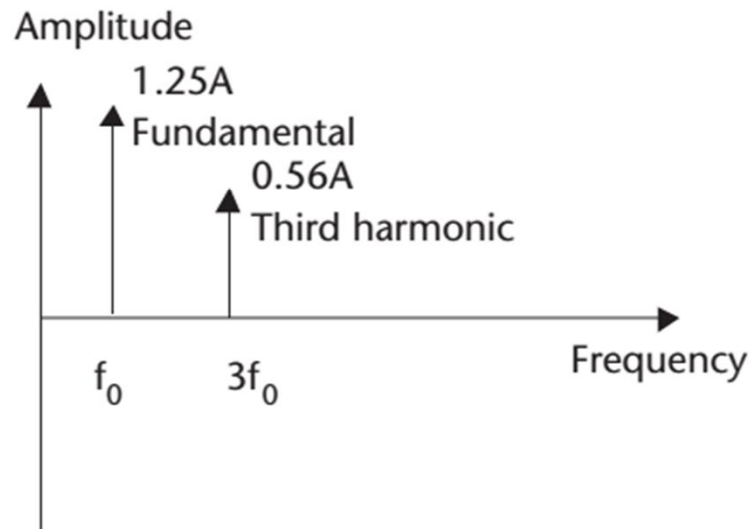

Pulsa Segiempat Periodik

Konstruksi sinyal pulsa segiempat dari sinyal sinusoidal:

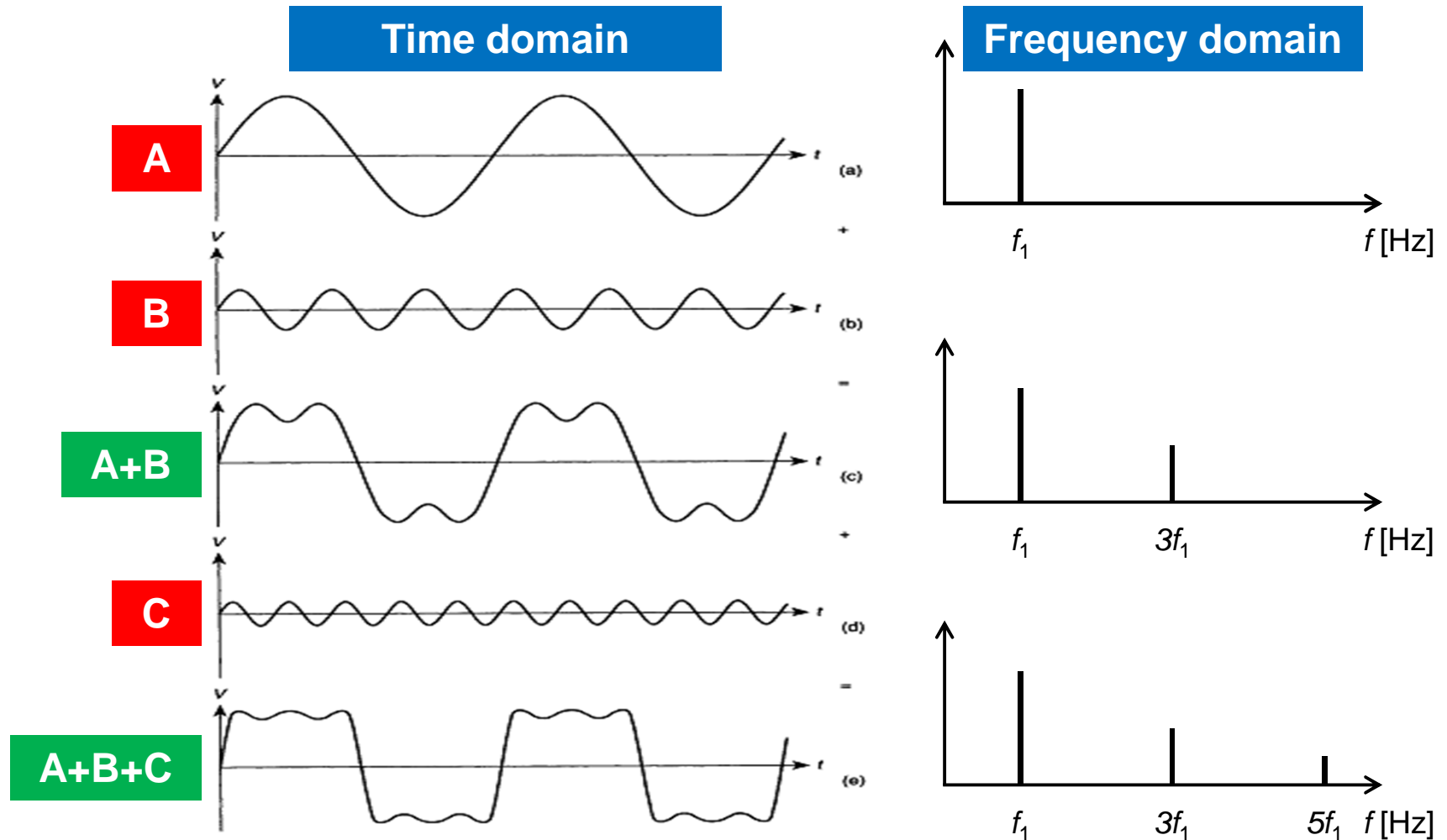

Sinyal Pulsa; non-periodik vs periodik

Time domain

Frequency domain

single pulse
(non-periodik)

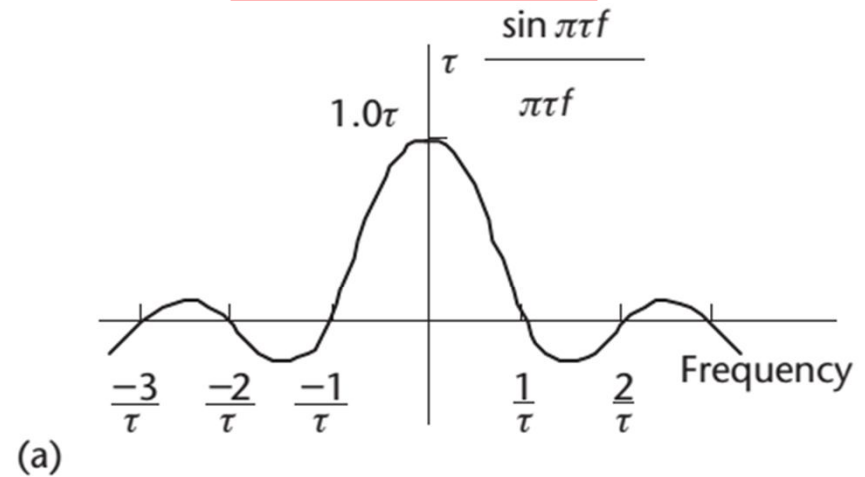
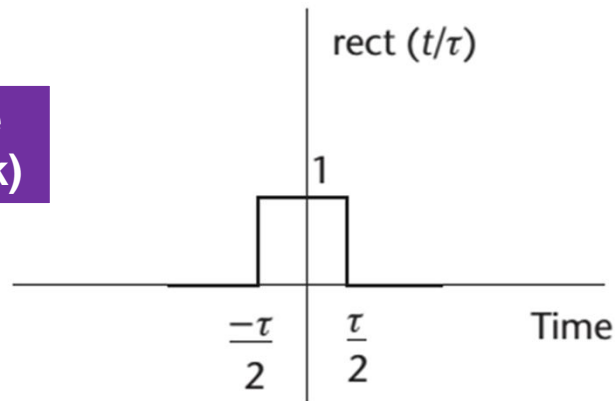

pulse train
(periodik)

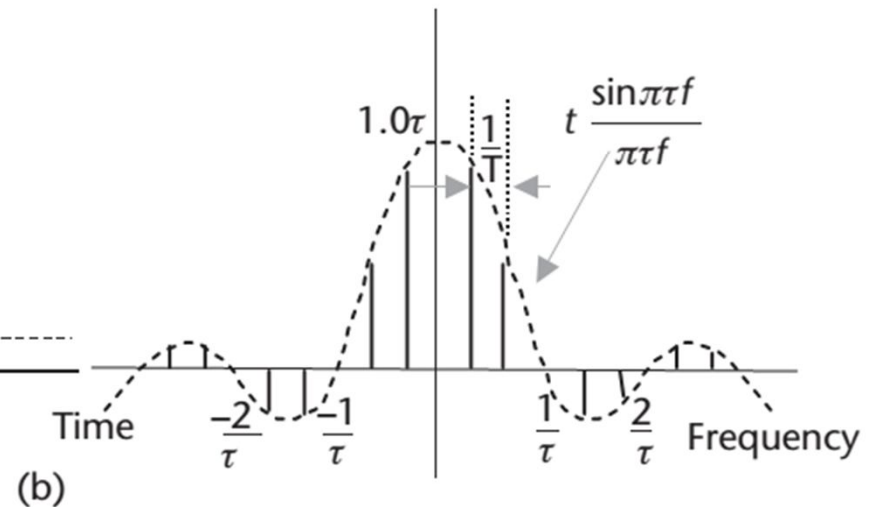
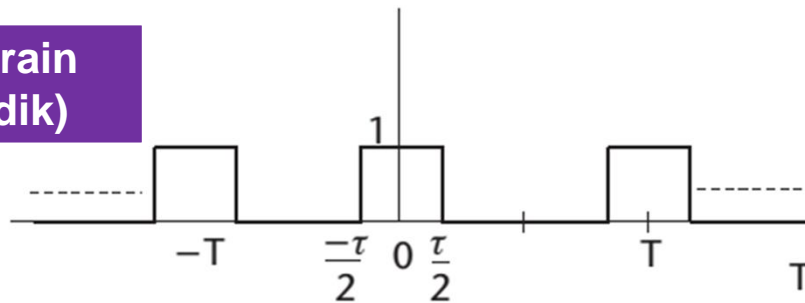

Durasi Pulsa vs *Bandwidth*

- **Durasi pulsa** berbanding terbalik thdp ***bandwidth* sinyal**.
- Pada transmisi pita dasar (*baseband*): **$BW = 1/T$** .

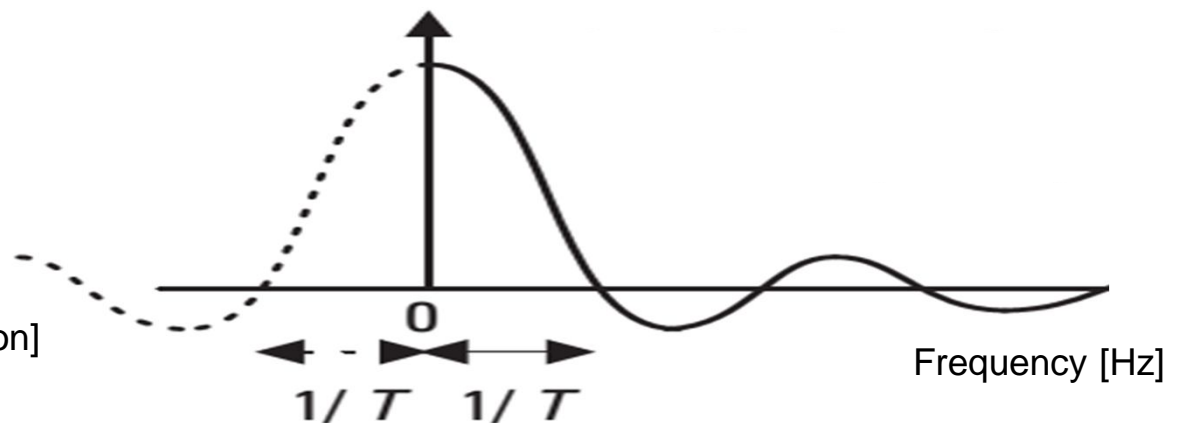
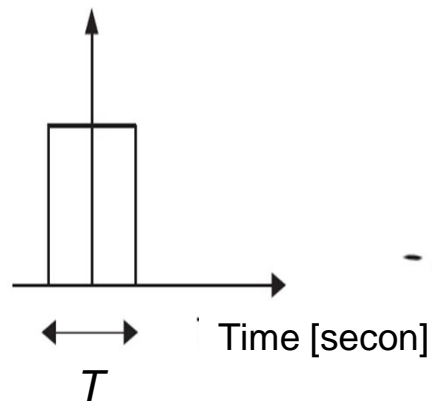
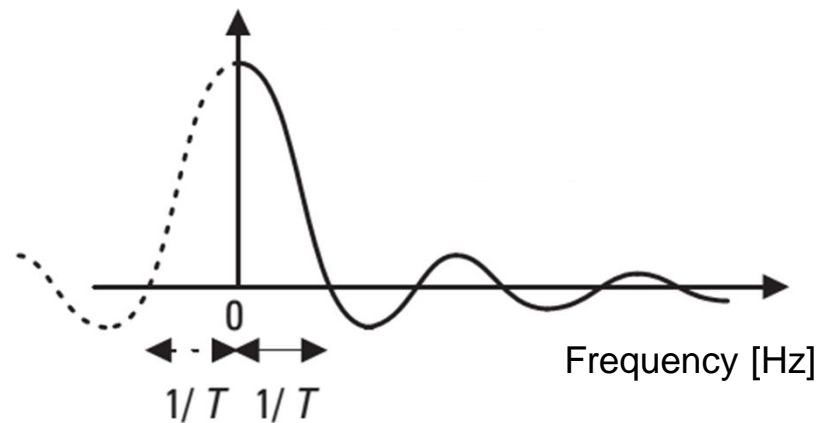
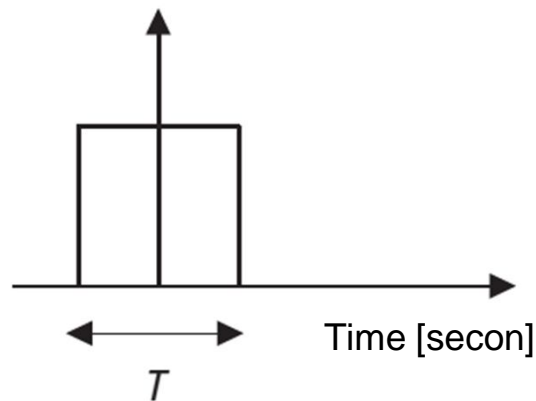

Rectangular-Pulse vs Sinc-Pulse

Time domain

Frequency domain

Rectangular pulse

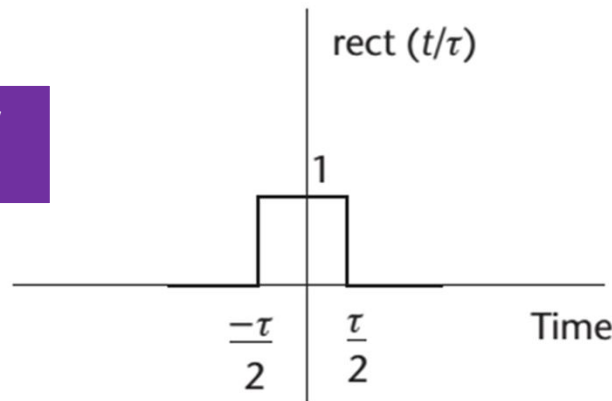

FT
IFT

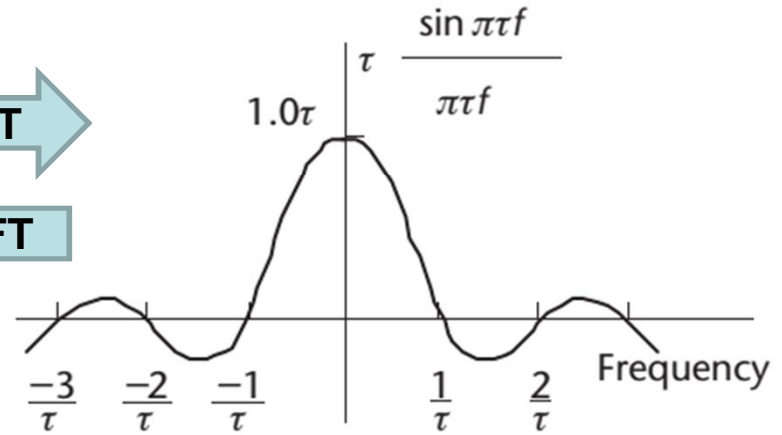

Sinc pulse

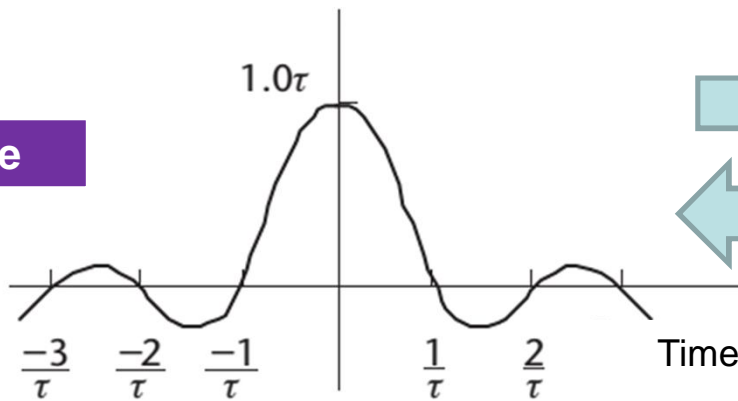

FT
IFT

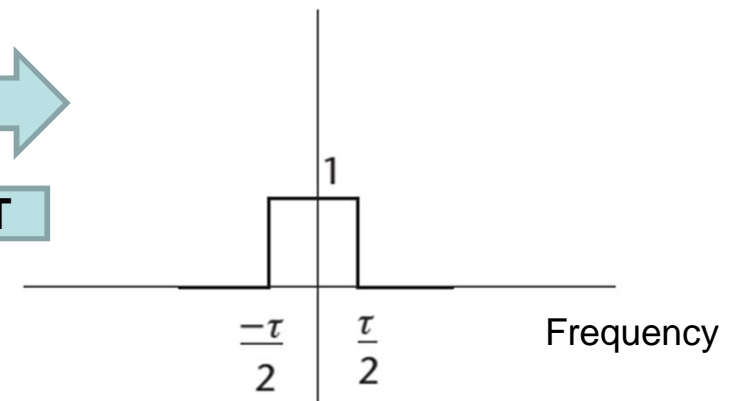

Note: FT = Fourier Transform, IFT = Inverse Fourier Transform

Amplitude Spectrum vs Power Spectrum

Time domain

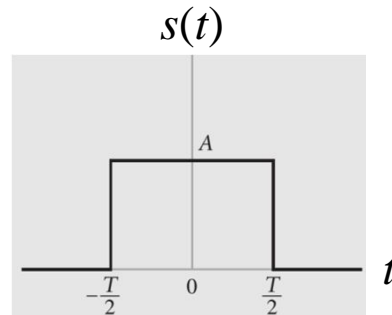

(a). Waveform of rectangular pulse

Frequency domain

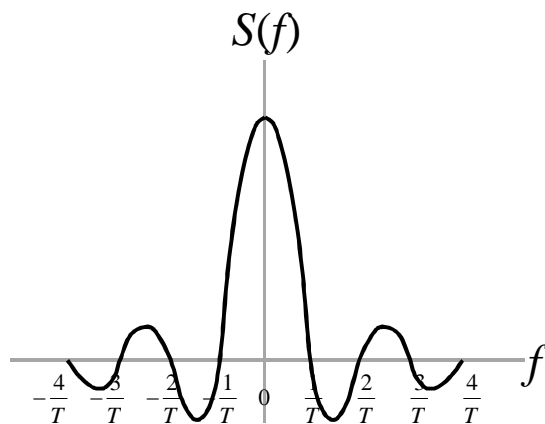

(b). Amplitude spectrum
(real value)

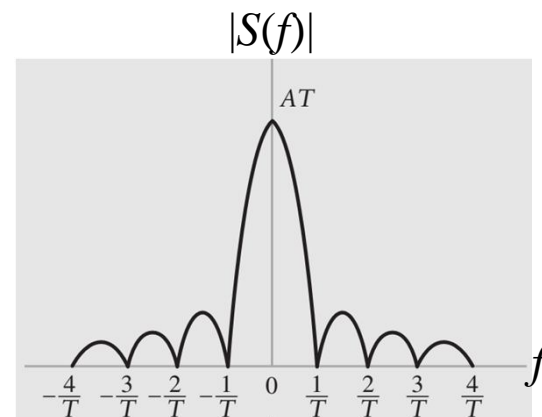

(c). Amplitude spectrum
(magnitude value)

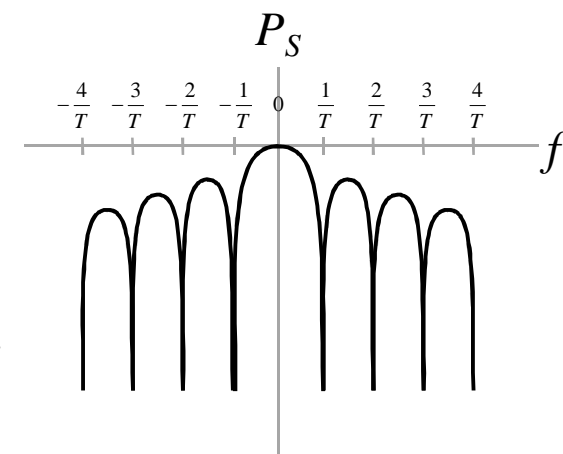

(d). Power spectrum;
 $P_S = 10 \log|S(f)|^2$



Signals in Communications

- Introduction
- Basics of Signal
- **Characteristics of analog voice channels**
- Fundamental differences between analog and digital signals
- Analog-to-digital conversion
- Signal power



Frequency and Bandwidth (1)

- *The **frequency** refers to the number of cycles through with the wave oscillates in a second.*
- Suatu **sinyal** transmisi terdiri dari banyak frekuensi. Jangkauan (*range*) dari frekuensi ini disebut **lebar pita (*bandwidth*)** sinyal.

Frequency and Bandwidth (2)

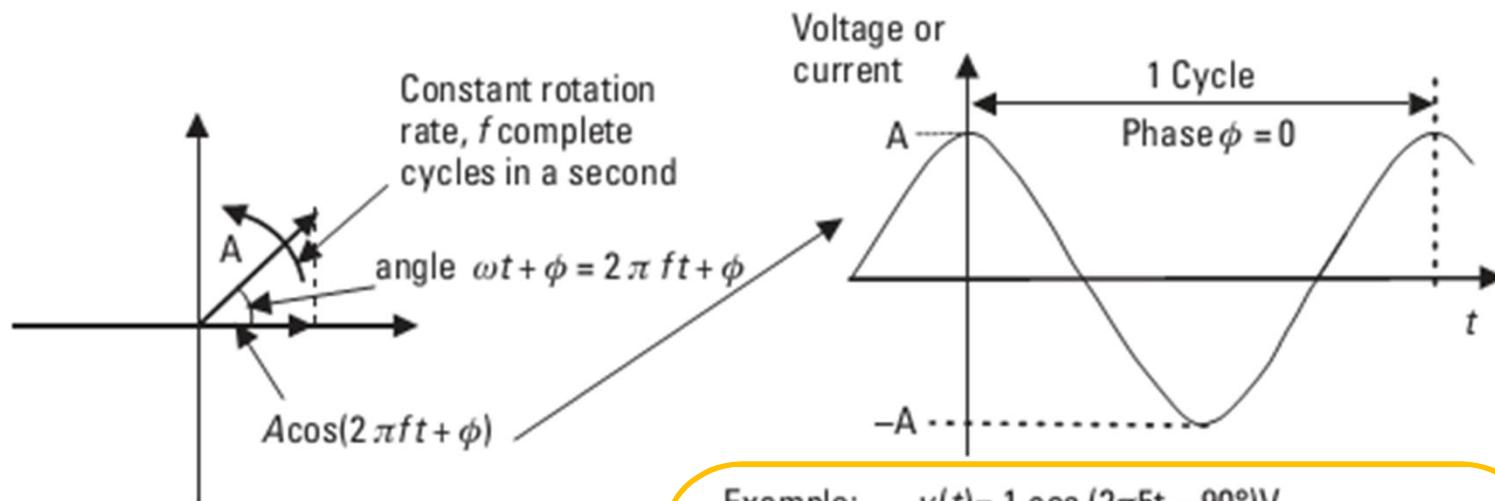

Wavelength: How long distance signal propagates during one cycle or periodic time.

$$\lambda = c / f$$

c = velocity, speed of the wave

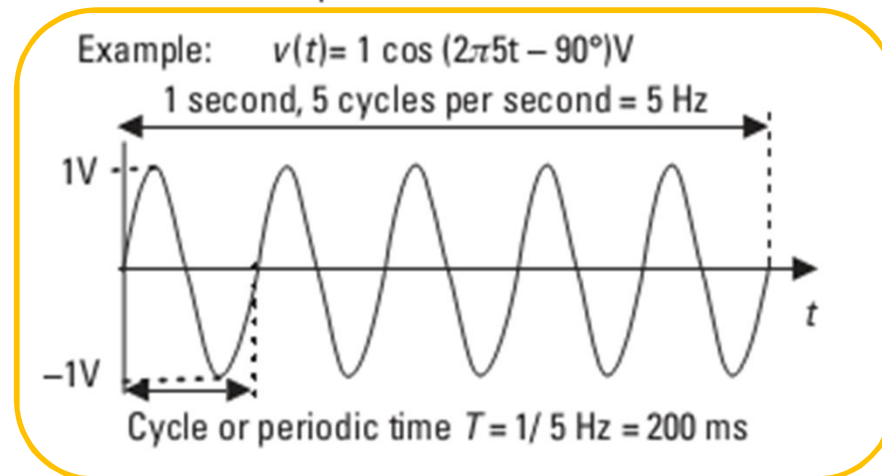

Frequency and Bandwidth (3)

- Misalkan suatu sinyal telekomunikasi

$$v(t) = A \cos(\omega t + \phi) = A \cos(2\pi f t + \phi)$$

dimana: f adlh frekuensi dlm Hertz, t adlh waktu dlm detik atau sekon, ϕ adlh sudut fase dlm radian, ω adlh frekuensi sudut (anguler) dlm radian/detik, dimana $\omega = 2\pi f$.

- Periode T adlh

$$T = 1/f \quad \text{dan} \quad f = 1/T$$

- Panjang gelombang λ adlh

$$\lambda = c/f = cT$$

- Dimana utk gelombang cahaya dan gelombang radio, $c = 3 \times 10^8$ m/s. Utk gelombang suara (*sound*), kecepatannya di udara adlh 346 m/s.

Frequency and Bandwidth (4)

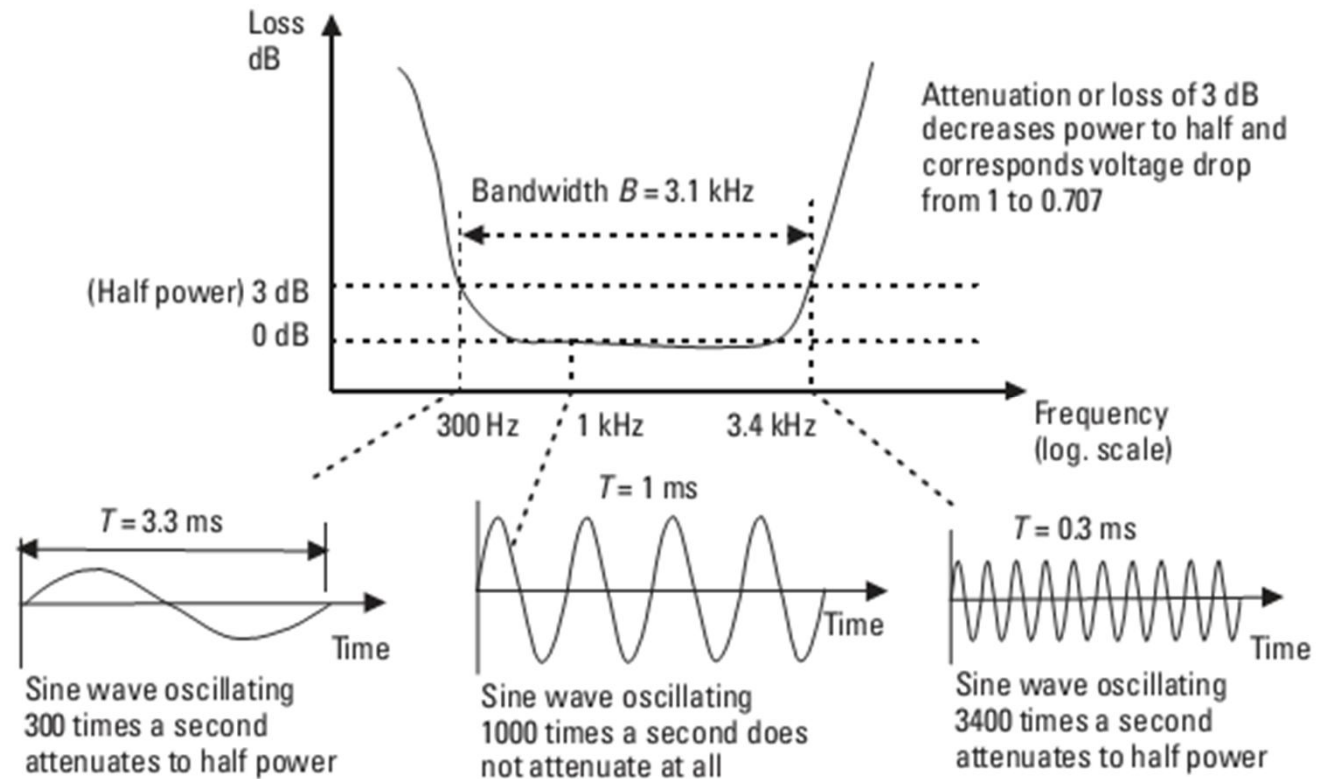

Bandwidth kanal telepon adlh $3400 - 300$ Hz = 3,1 kHz.

Suara

- **Speech** → suara yg diucapkan manusia (35 – 10.000 Hz)
- **Audio** → suara yg mampu didengar oleh telinga manusia (20 – 20.000 Hz)
- **Sound** → bunyi (semua/sembarang suara)
- **Voice** → *speech* yg telah difilter (300 – 3.400 Hz)



Signals in Communications

- Introduction
- Basics of Signal
- Characteristics of analog voice channels
- **Fundamental differences between analog and digital signals**
- Analog-to-digital conversion
- Signal power

Perbedaan sinyal analog dan sinyal digital

Analog and digital watch

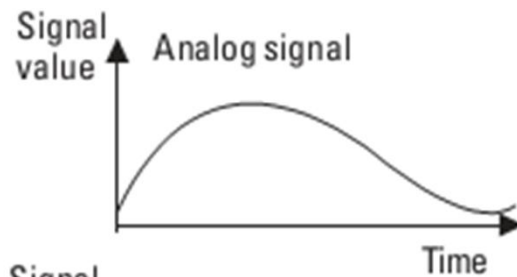

02:05

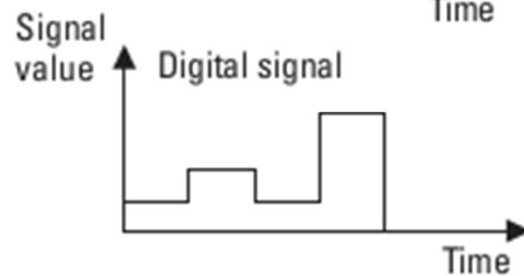

Slope of analog and digital voltages.

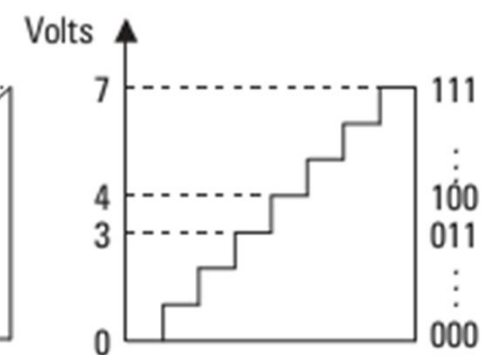
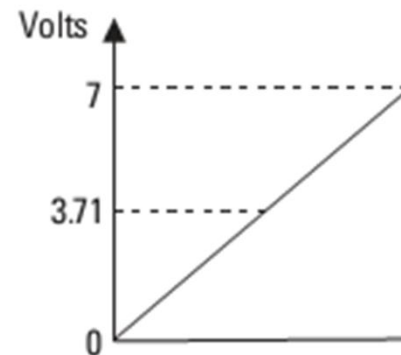



Jenis-jenis Sinyal

- **Sinyal analog**
(waktu kontinu, nilai kontinu)
- **Sinyal diskrit**
(waktu diskrit, nilai kontinu)
- **Sinyal digital**
(waktu diskrit, nilai diskrit)
- **Sinyal biner**
(sinyal digital dgn dua nilai saja; utk merepresentasikan 0 dan 1).

Transmisi Sinyal Analog

Sinyal yg dikirimkan

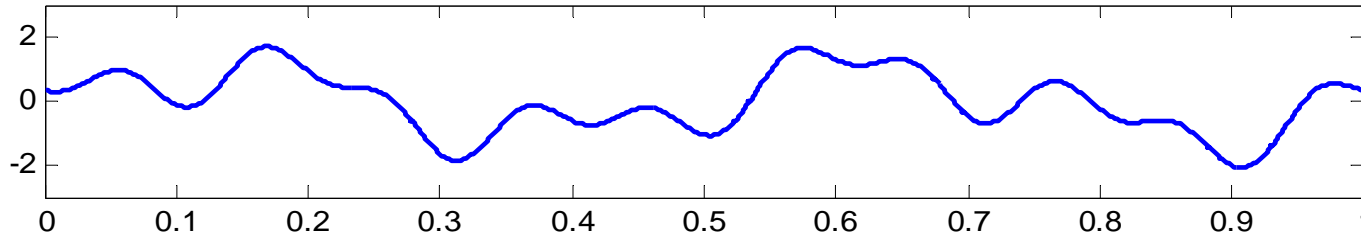

Sinyal yg mengalami redaman

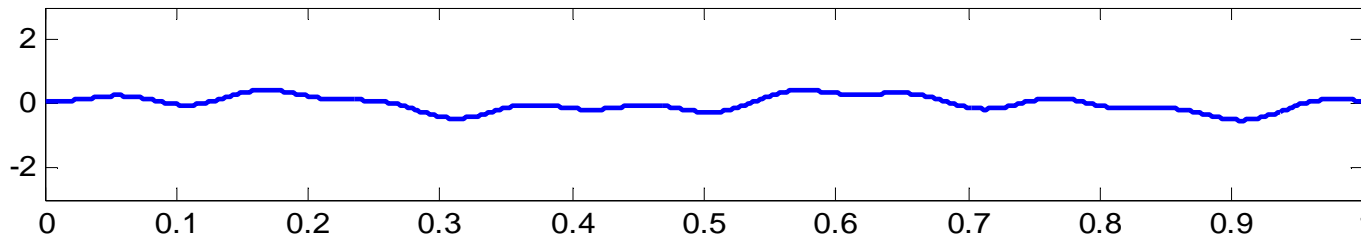

Sinyal yg teredam mengandung noise

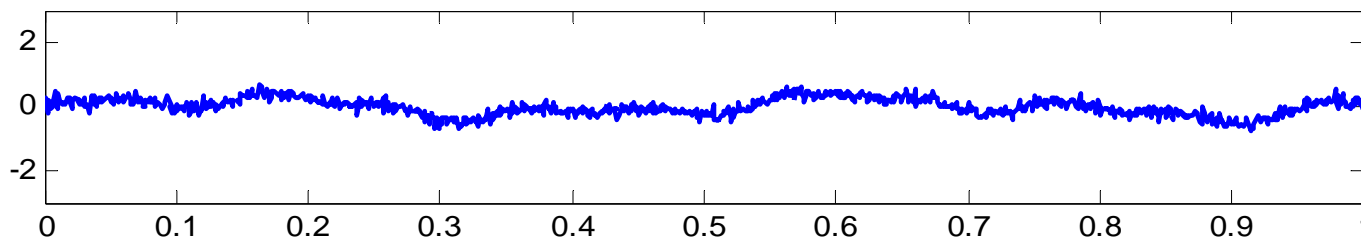

Sinyal setelah diperkuat di penerima

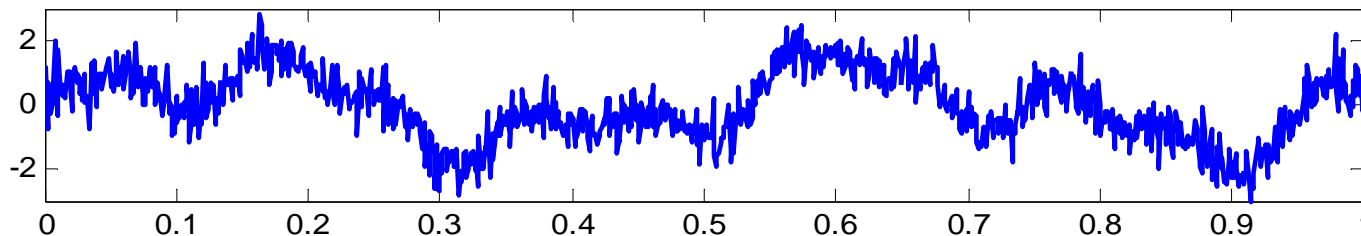

Why Digital?

- Digital pulse degradation and regeneration

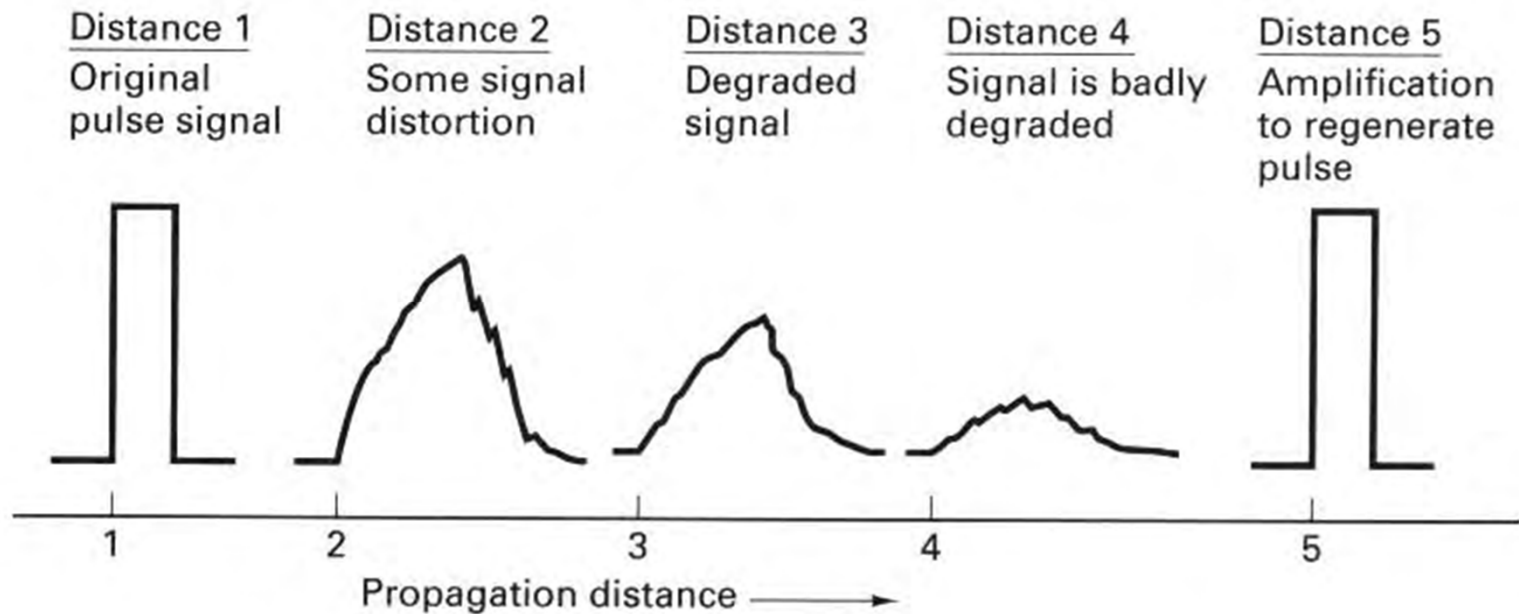

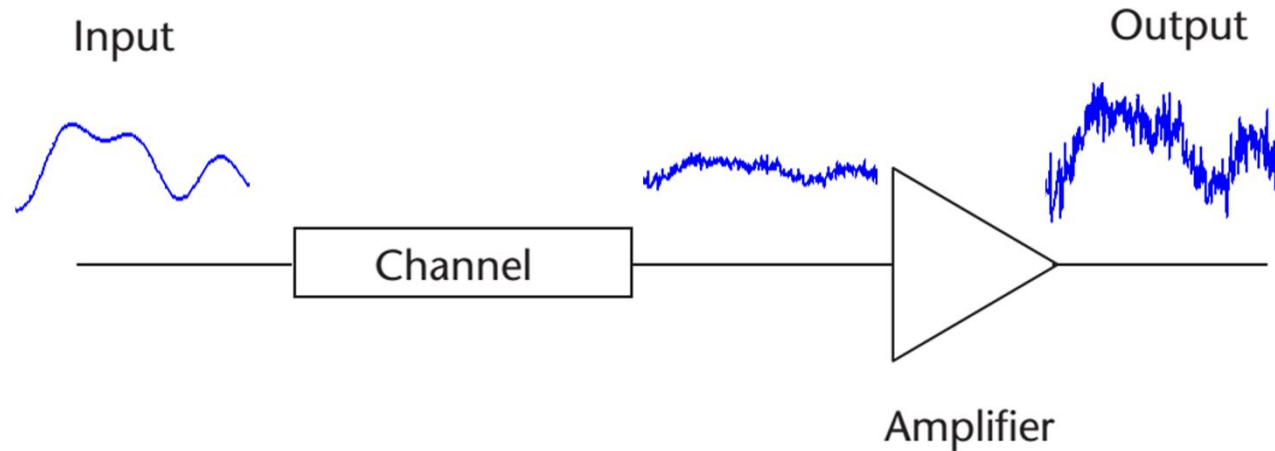

Transmisi Analog vs. Transmisi Digital

Analog

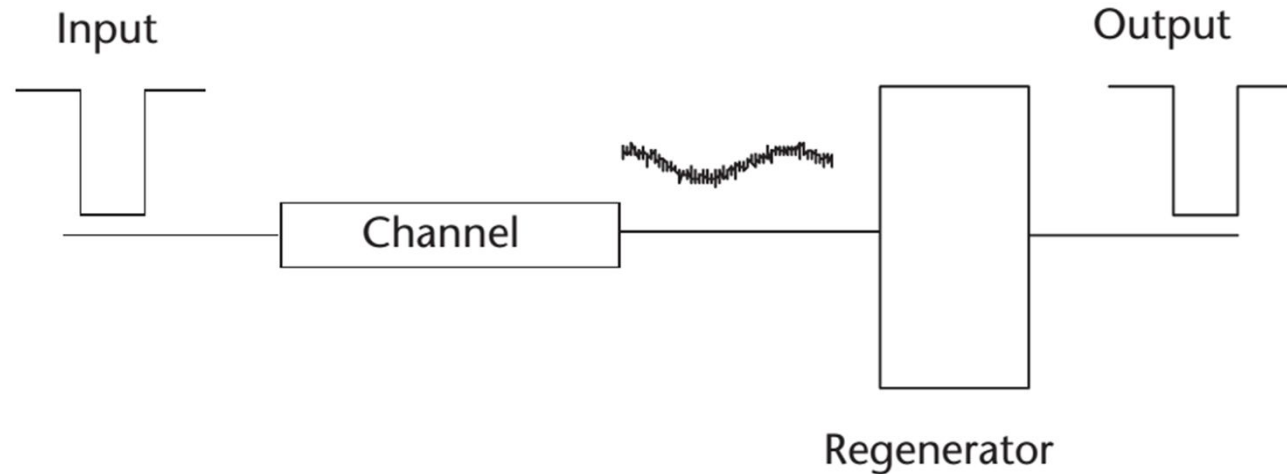

Digital





Keuntungan teknologi digital dibandingkan teknologi analog

- Digital functions make a high scale of integration possible.
- Digital technology results in lower cost, better reliability, less floor space, and lower power consumption.
- Digital technology makes communication quality independent of distance.
- Digital technology provides better noise tolerance.
- Digital networks are ideal for growing data communication.
- Digital technology makes new services available.
- Digital system provides high transmission capacity.
- Digital networks offer flexibility.



Beberapa kondisi

- Sinyal informasi **analog**, transmisi **analog**
- Sinyal informasi **digital**, transmisi **analog**
- Sinyal informasi **digital**, transmisi **digital**
- Sinyal informasi **analog**, transmisi **digital**

Contoh message (information)

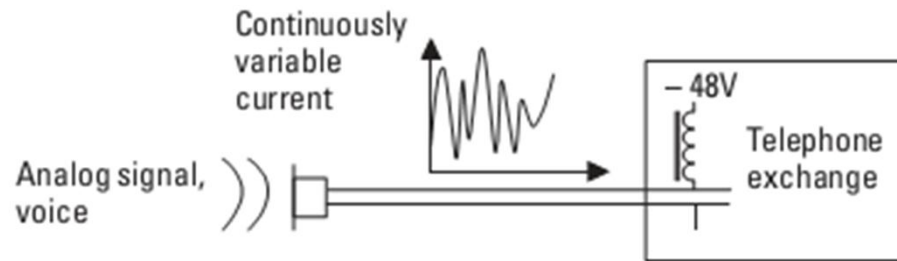

Sinyal informasi analog,
transmisi analog

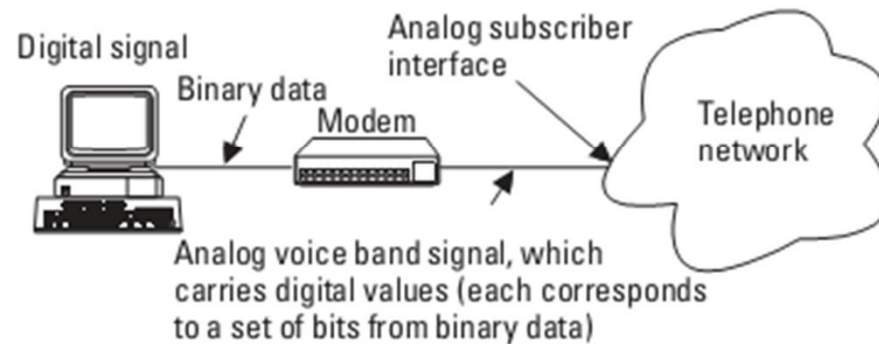

Sinyal informasi digital,
transmisi analog

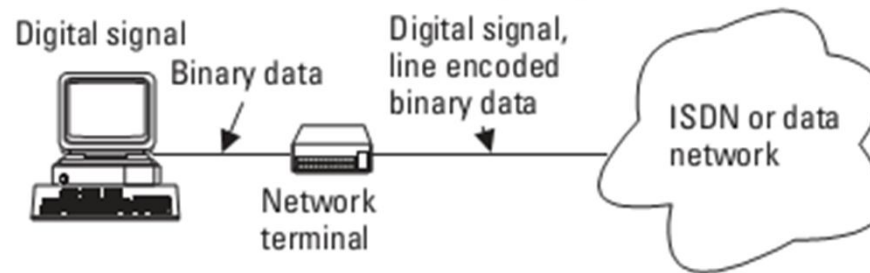

Sinyal informasi digital,
transmisi digital

Pengiriman sinyal analog melalui jaringan digital

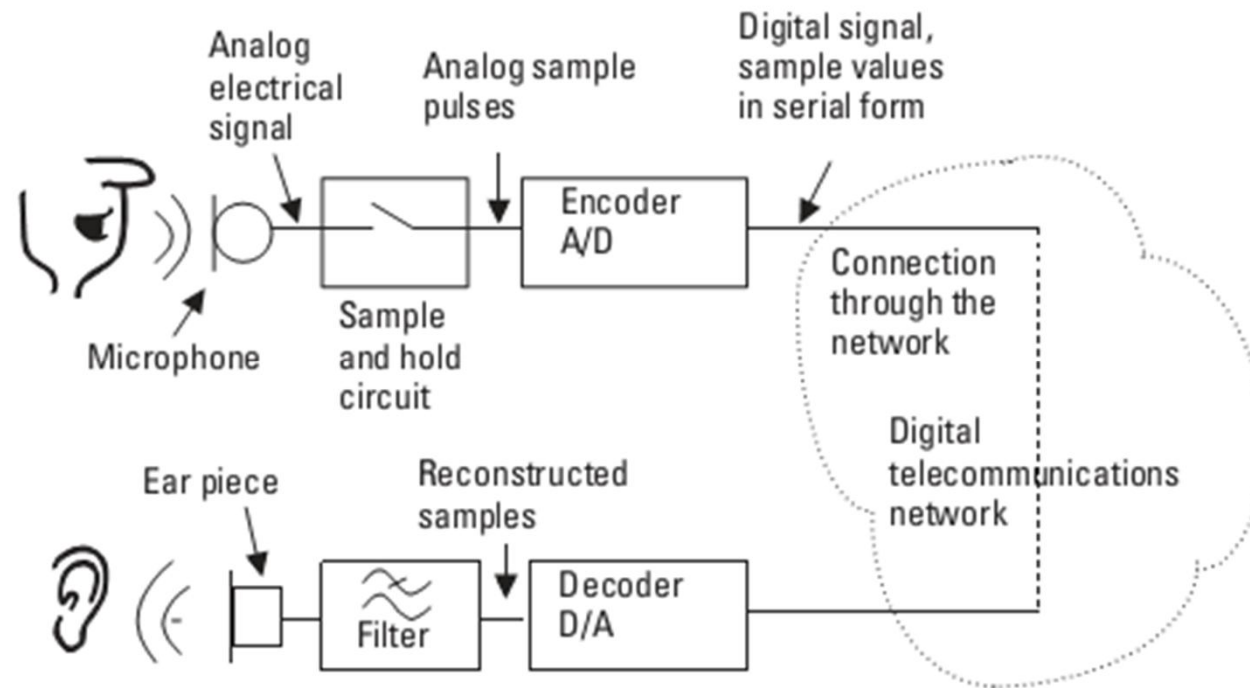

- Dua proses utama: *analog-to-digital conversion (A/D)* dan *digital-to-analog conversion (D/A)*.



Signals in Communications

- Introduction
- Basics of Signal
- Characteristics of analog voice channels
- Fundamental differences between analog and digital signals
- **Analog-to-digital conversion**
- Signal power

Analog to Digital Conversion

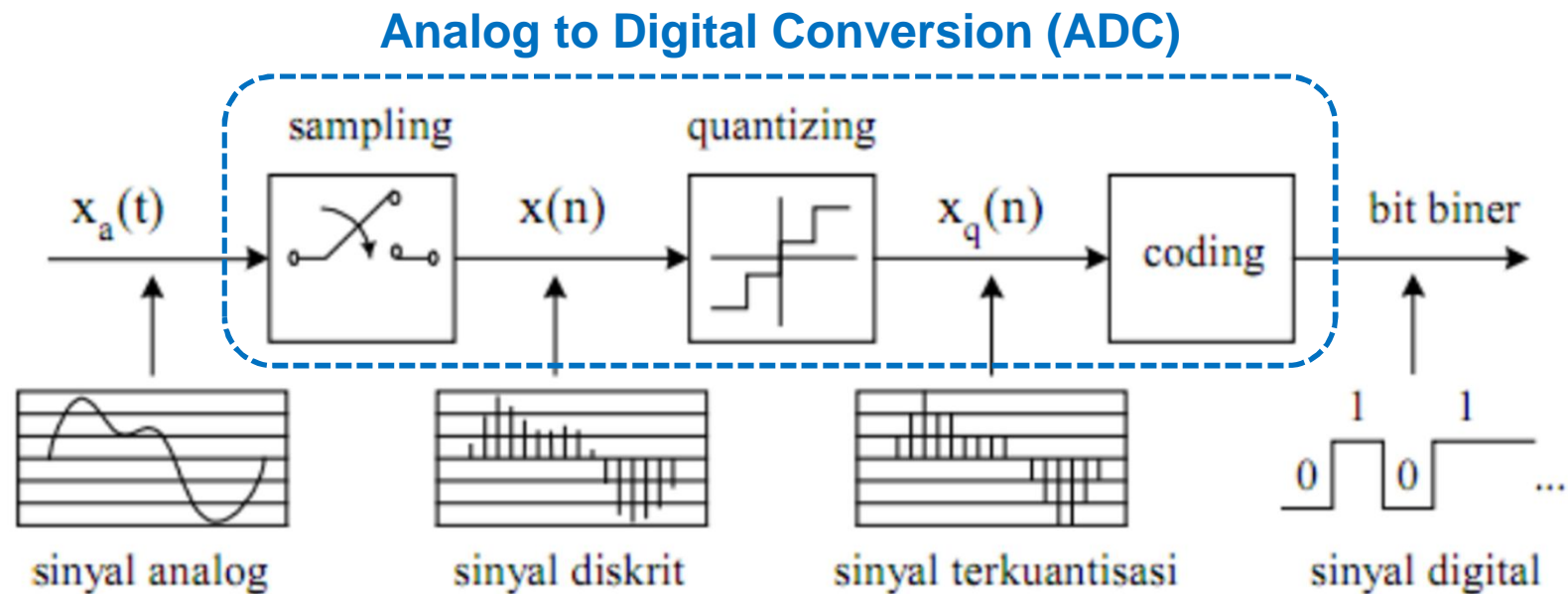

- **Sinyal informasi analog** untuk dpt ditransmisikan pd jaringan digital atau diolah pd perangkat digital maka harus diubah menjadi **sinyal digital**. Proses ini disebut *analog to digital conversion (ADC)*.
- Metode ADC untuk sinyal suara disebut **pulse code modulation (PCM)** dan telah ditetapkan standarnya.

Pulse Code Modulation (PCM)

- PCM adlh metode standar yg digunakan utk **mengubah sinyal analog** ke **sinyal digital** pd transmisi melalui jaringan telekomunikasi digital.
- **Pertama**, sinyal analog dicuplik pd sampling rate 8 kHz, kemudian (**kedua**) setiap sampel dikuantisasi (ada 256 level kuantisasi), dan **ketiga** dikodekan menjadi kata digital 8-bit. Note: 8 kHz adlh $2 \times f_{maks}$.
- Data rate keseluruhan dari suatu sinyal suara menjadi $8.000 \times 8 = 64$ Kbps. Di Amerika, satu dari delapan bit pd setiap frame keenam dipakai utk in-band signalling, shg kapasitas data berkurang mjd $8.000 \times 7 = 56$ Kbps.

PCM (lanjutan)

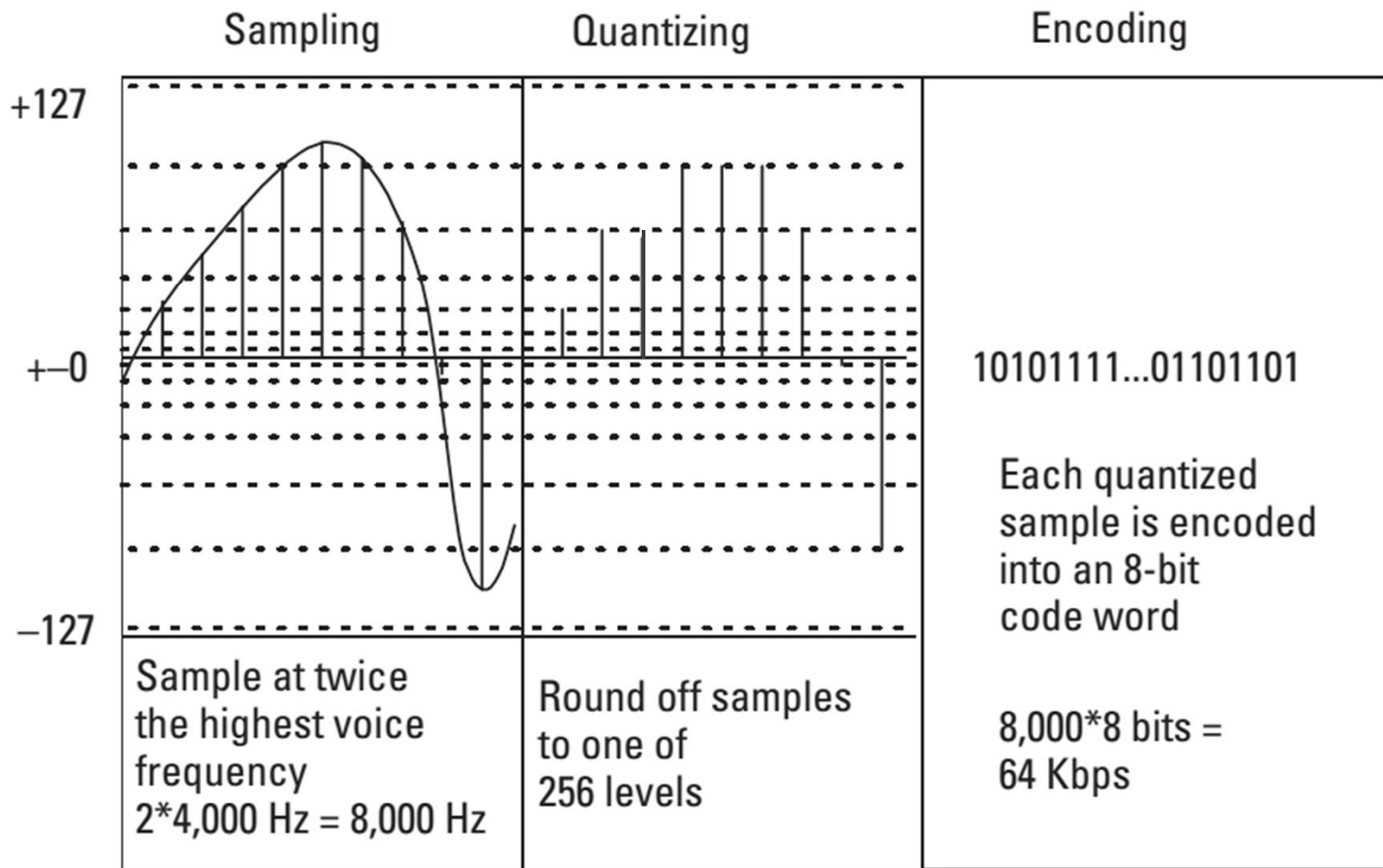

Pencuplikan (Sampling)

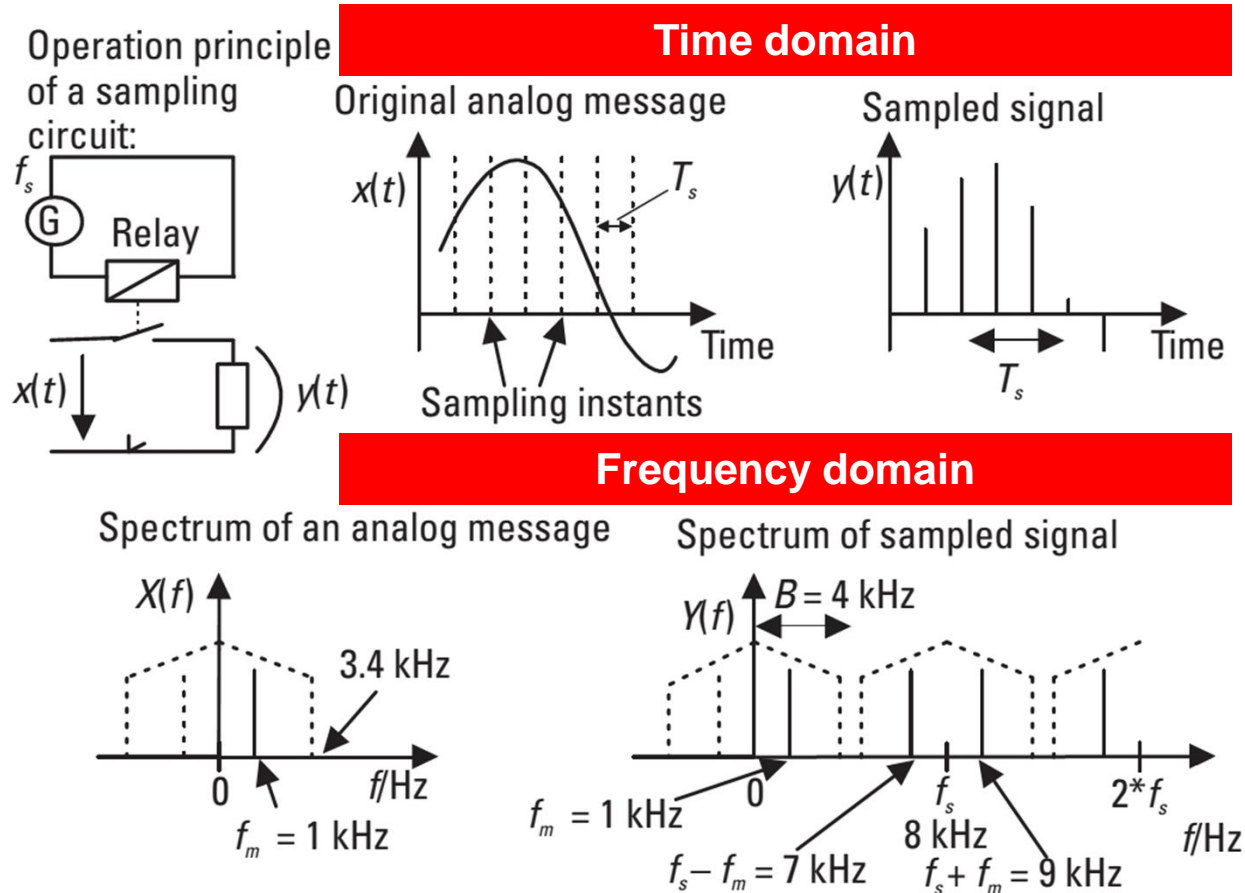

- Keluaran dari proses sampling adlh **sinyal PAM** (*pulse amplitude modulation*) yg merupakan **sinyal diskrit** (waktu diskrit, nilai kontinu).

Kuantisasi (Quantizing)

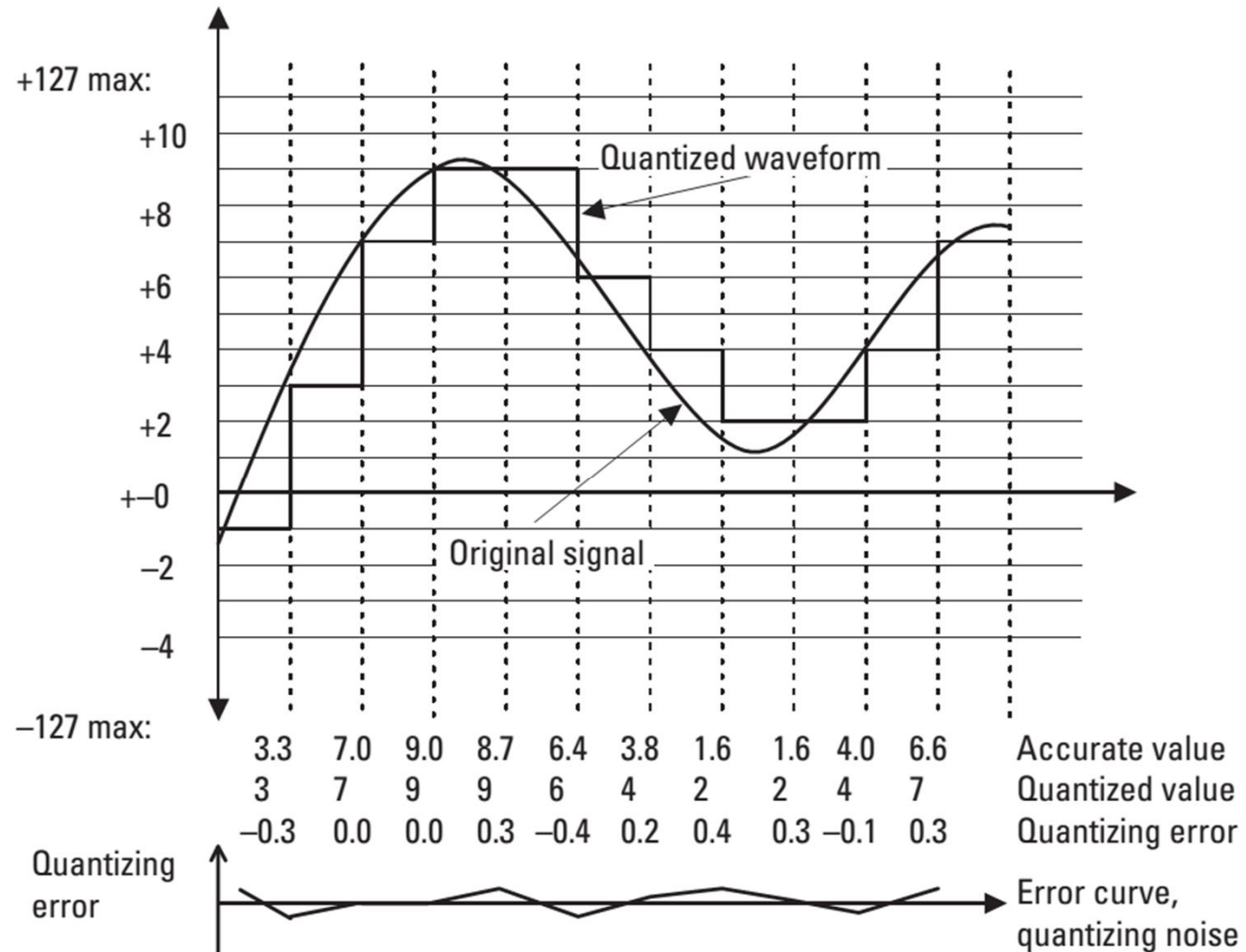

Derau Kuantisasi (Quantizing Noise)

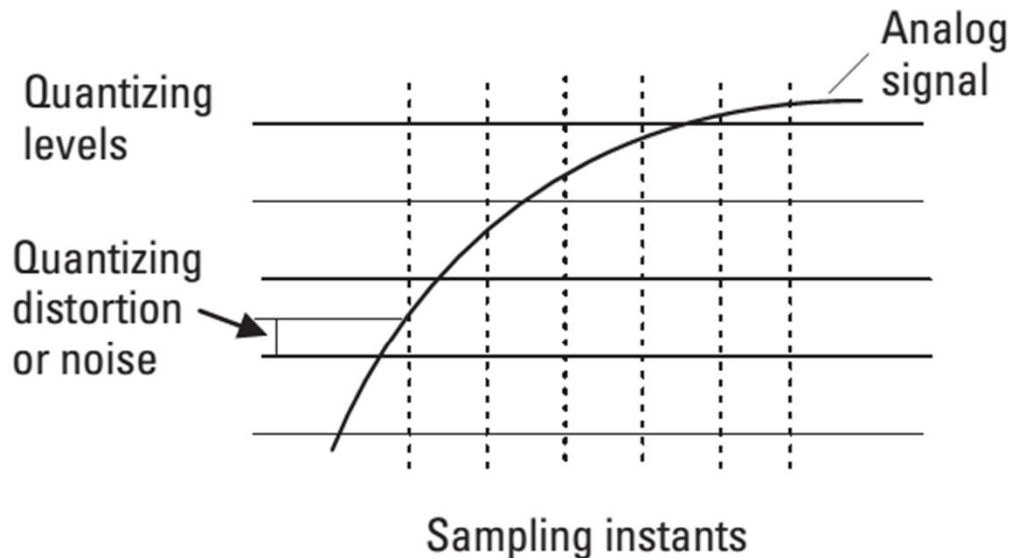

Maximum signal to
quantizing noise ratio:

$S/N \leq 4.8 + 6.0 n$ dB
where n is the number
bits/binary sample word

Practical figures are much
(10–30 dB) lower.

The more levels (the more bits/sample, the higher bit rate) we use,
the better performance we get (i.e., higher signal to noise ratio).



Daya noise kuantisasi

- **Error kuantisasi** dpt diasumsikan mempunyai *probability density function* yg terdistribusi *uniform* dgn *mean nol*.
- Jika kita definisikan sinyal memiliki nilai antara -1 ... +1, maka **daya noise kuantisasi** adalah variansi error kuantisasi, yg diberikan oleh

$$N = \sigma_q^2 = \frac{1}{3q^2}$$

dimana $N = \sigma_q^2$ = daya noise kuantisasi dan q = banyaknya level kuantisasi.



Signal-to-quantizing noise ratio (SQR)

- ***Signal-to-quantizing noise ratio (SQR)*** dari kuantisasi linier jika daya sinyal maksimum sama dgn satu adalah

$$SQR = S/N \leq 3q^2$$

dimana S = daya sinyal, N = daya noise kuantisasi, dan q = banyaknya level kuantisasi.

- **S/N** adalah ***signal-to-noise ratio***, dpt juga ditulis dgn **SNR**.

SQR kuantisasi linear dan kata biner

- Utk kuantisasi linear dan menggunakan kata biner, maka S/N maksimum dlm decibel adalah

$$S / N \leq 10 \log(3q^2) = 10 \log(3 \cdot 2^{2n}) = 4,8 + 6n \text{ dB}$$

dimana n = jumlah bits/word atau jumlah bit/sampel.

Catatan:

Sepanjang kuliah ini, $\log(x)$ adalah menyatakan logaritma berbasis 10 yaitu sama dengan $\log_{10}(x)$ atau ${}^{10}\log(x)$.

Kuantisasi: Uniform vs Non-Uniform

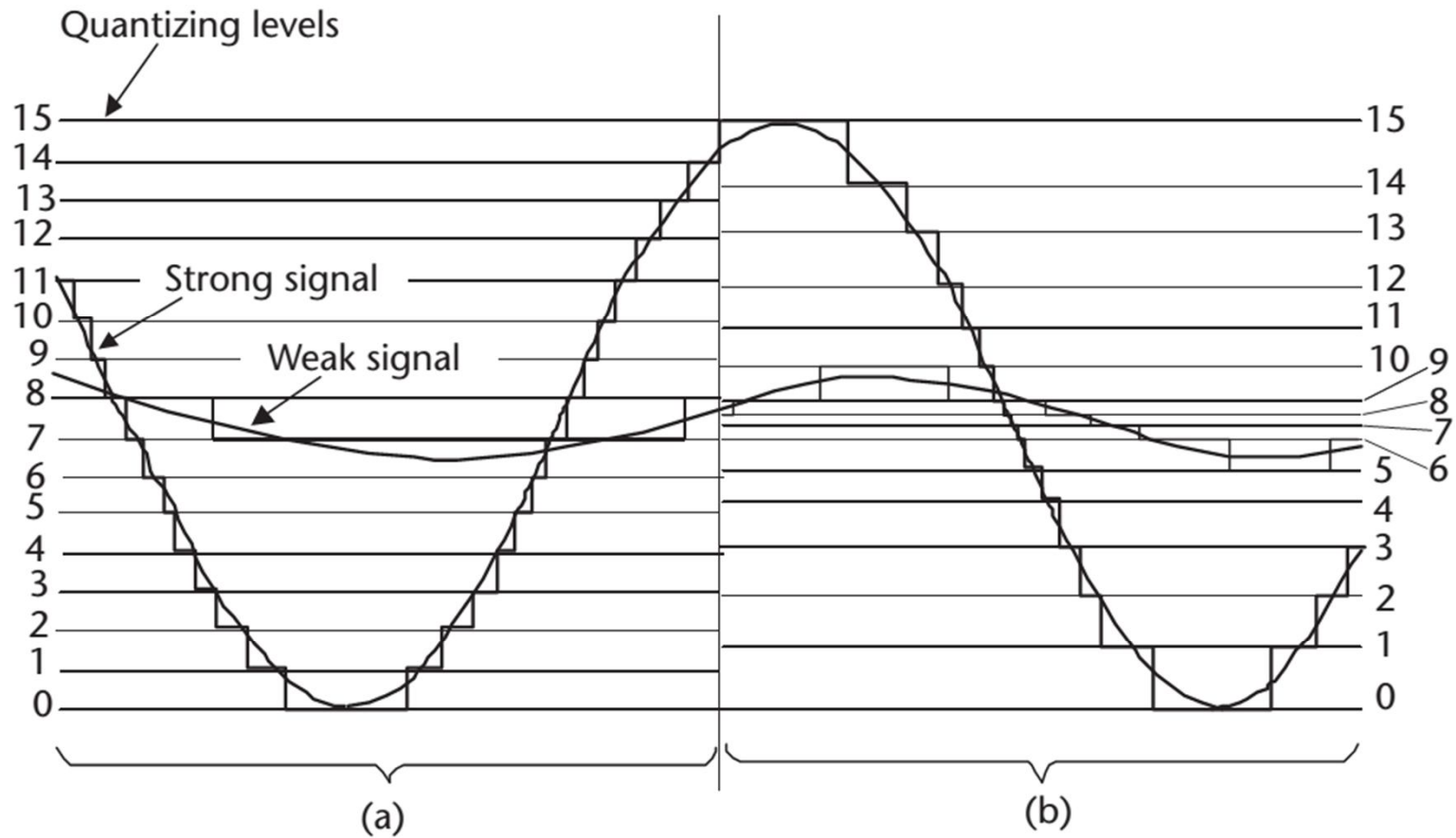
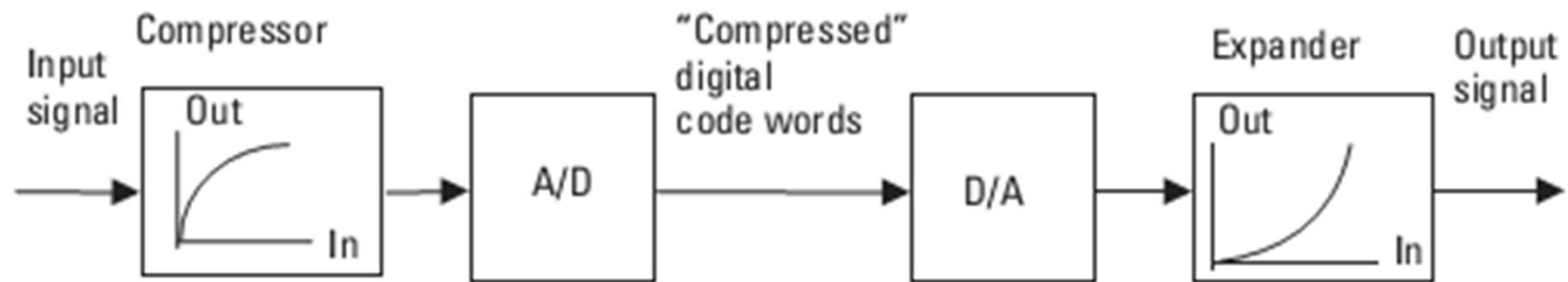
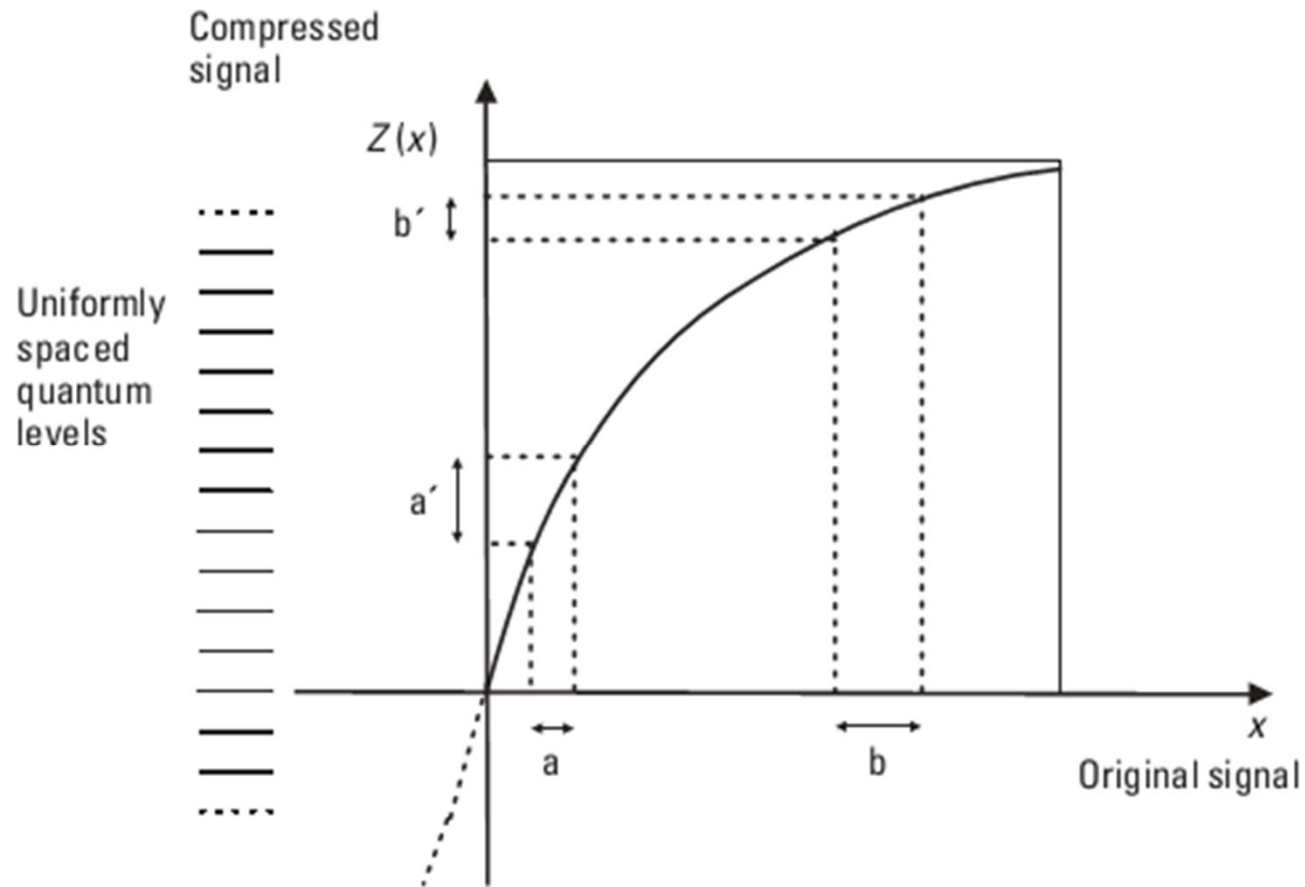

Figure 2.8 Quantization: (a) uniform, and (b) nonuniform.

Non-Uniform Quantizing



Non-Uniform Quantizing (2)



Algoritma Componding

- Proses *compressing/expanding* pd kuantisasi non-uniform biasa disebut **componding**.
- **Dua algoritma componding standar** adlh:
 - **A-law**; yg digunakan di Eropa, didefinisikan sbb:

$$Z(x) = \begin{cases} \operatorname{sgn}(x) \cdot \frac{1 + \ln A|x|}{1 + \ln A} & \text{for } \frac{1}{A} < |x| < 1 \\ \frac{Ax}{1 + \ln A} & \text{for } \frac{-1}{A} < x < \frac{1}{A} \end{cases}$$

- **μ -law**; yg digunakan di Amerika Utara dan Jepang

$$Z(x) = \operatorname{sgn}(x) \cdot \frac{\ln(1 + \mu|x|)}{\ln(1 + \mu)}$$

Pengkodean Biner (Binary Coding)

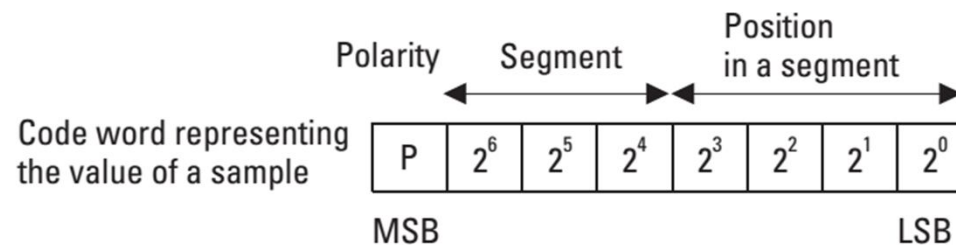
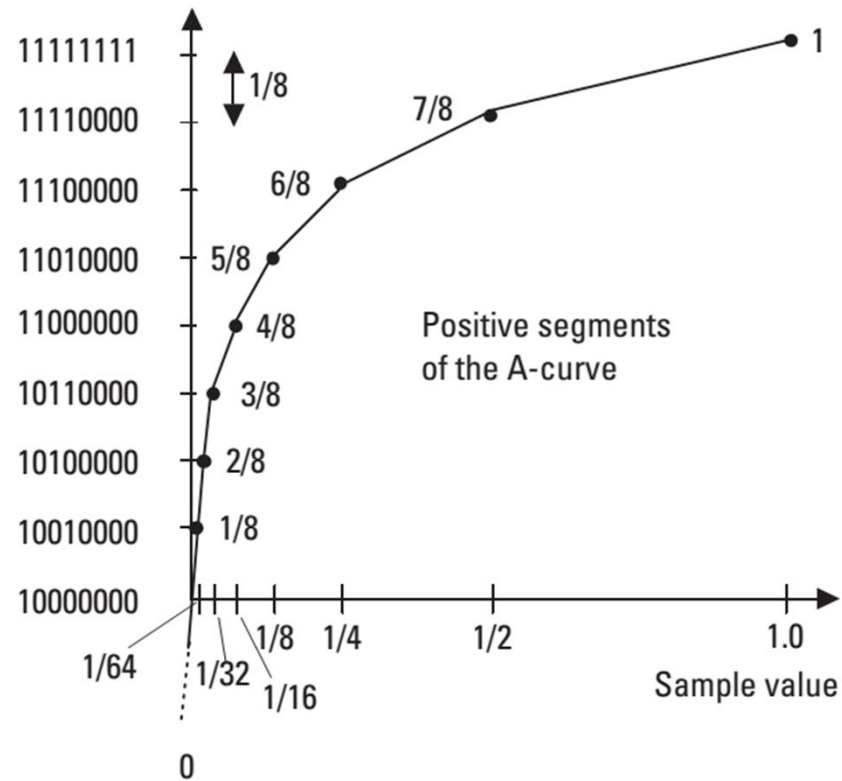

PCM Encoder

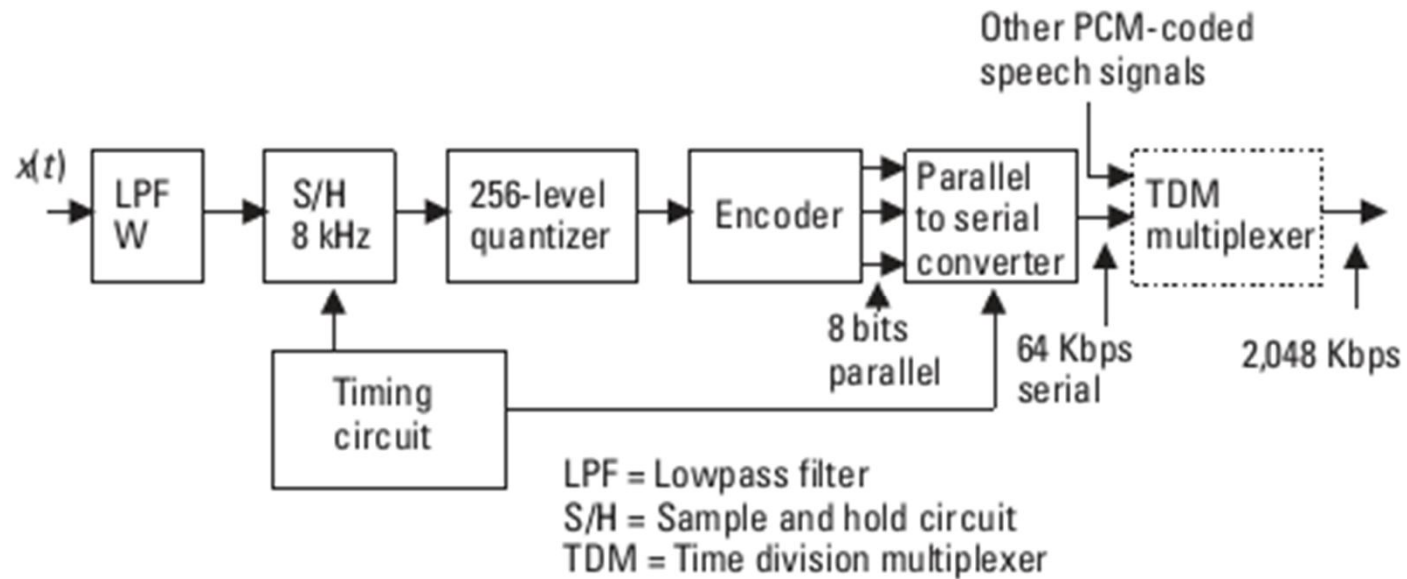

PCM Decoder

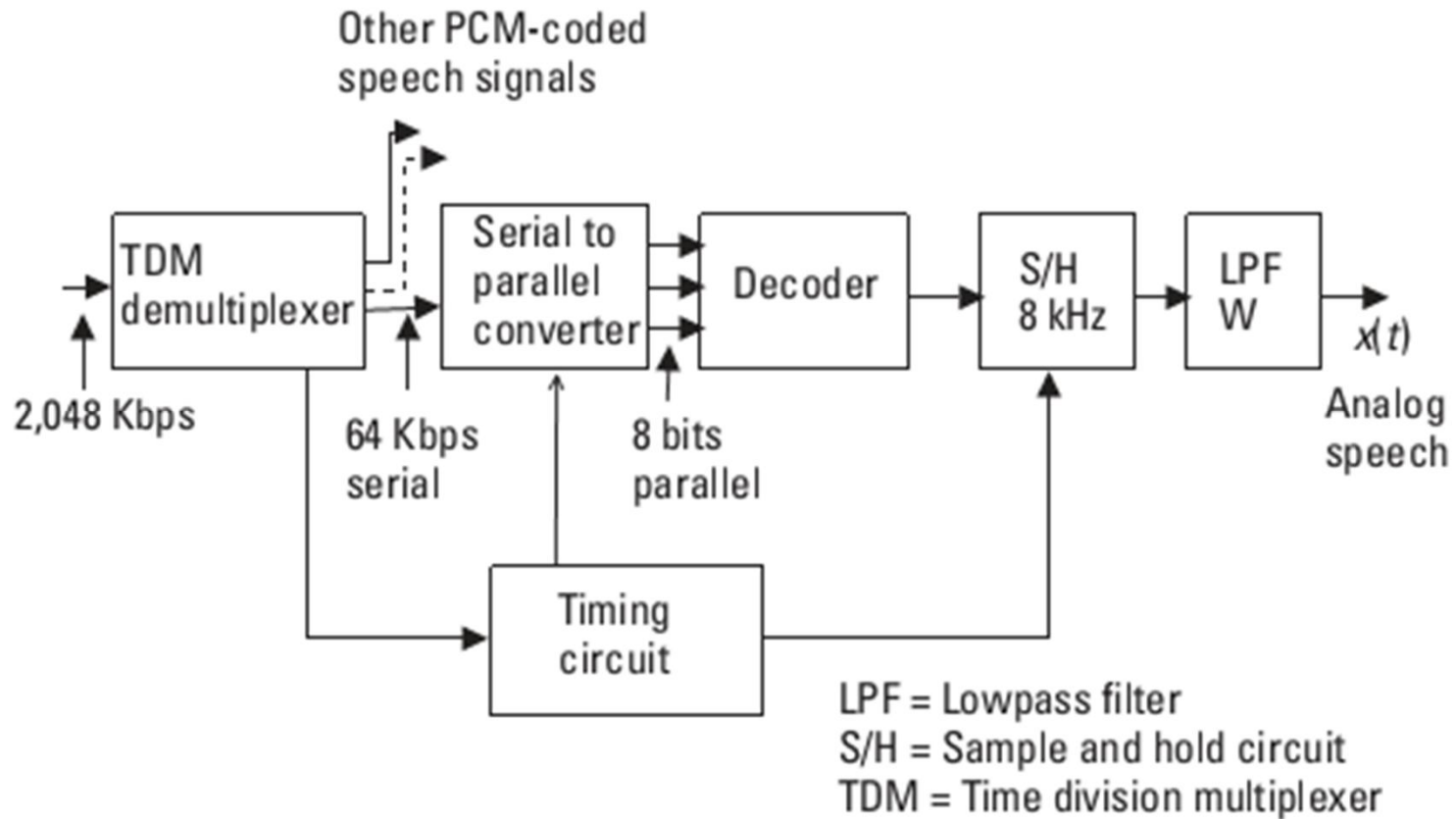



Metode-metode pengkodean suara lain

- Adaptive PCM (APCM)
- Differential PCM (DPCM)
- Delta Modulation (DM)
- Adaptive DPCM (ADPCM)
- GSM speech coding (hybrid)

Note: “Riset di dalam *speech coding* terus berkembang yg selalu mencari teknik coding yg mampu memberikan data rate yang sekecil mungkin dgn kualitas yang masih dapat diterima”

- Tujuannya agar jumlah pembicaraan di dalam jaringan dpt meningkat walaupun kapasitas jaringan tetap.



Contoh Soal

1). Pulse Code Modulation (PCM)

Misalkan suatu sistem PCM sederhana digunakan utk mengkodekan sinyal informasi pd gambar berikut. Bila sinyal dicuplik dgn sampling rate $1/T$ Hz, lalu dikuantisasi dgn quantizer uniform 8-level, dan diencodekan menjadi kata-kata kode digital, maka:

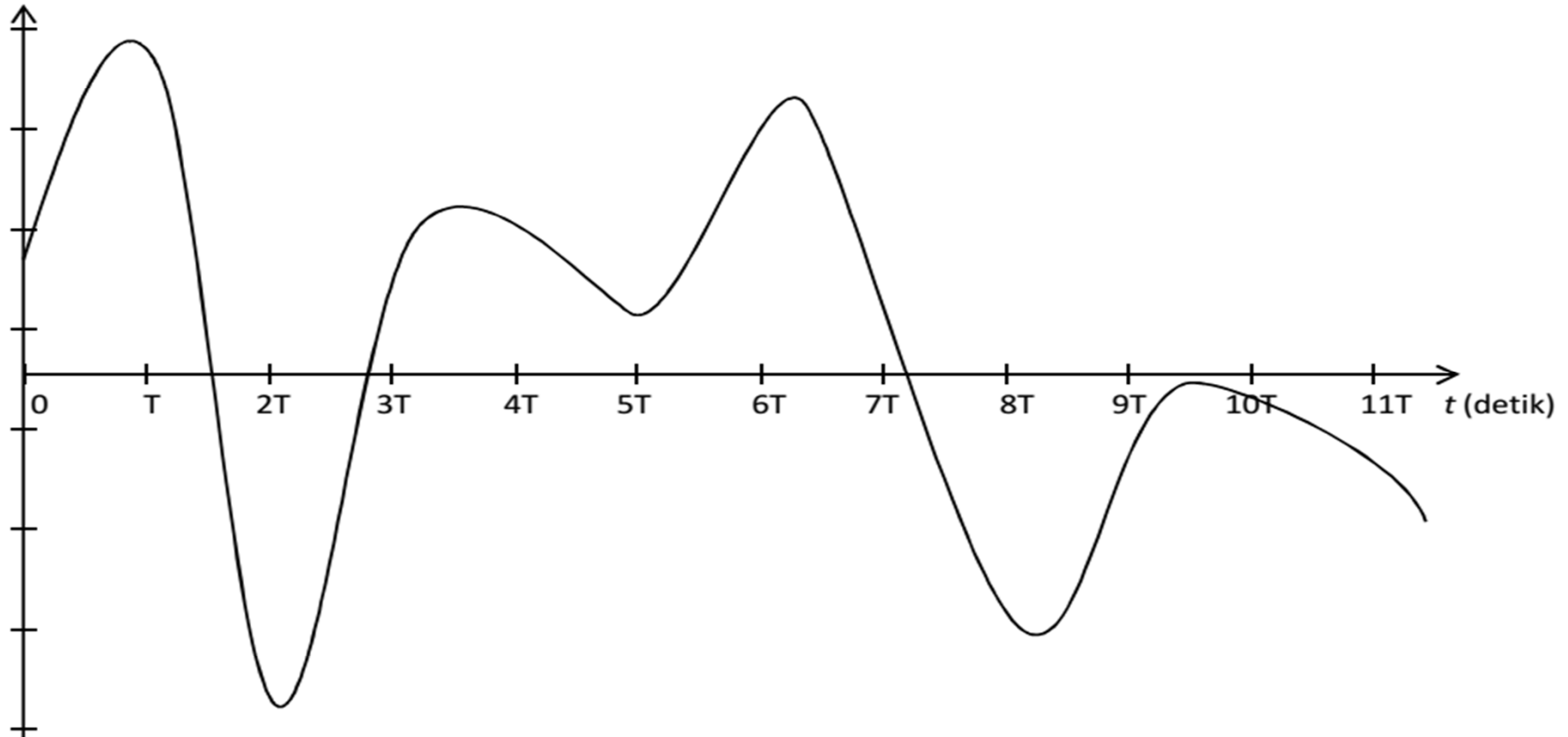

- (i). Gambarkan ilustrasi sinyal (berupa deretan sampel) hasil cuplikan!
- (ii). Gambarkan ilustrasi sinyal (berupa deretan sampel) hasil kuantisasi!
- (iii). Encodekan seluruh sampel yg ada menjadi kode digital (berupa deretan bit)!
- (iv). Bila $T = 2,5 \times 10^{-4}$ detik, berapakah data rate kode PCM tersebut?



Penyelesaian

Penyelesaian:

Untuk memudahkan dlm menjawab soal, kita gambarkan kembali sinyal informasi dan kita buat garis-garis bantu (gridline).

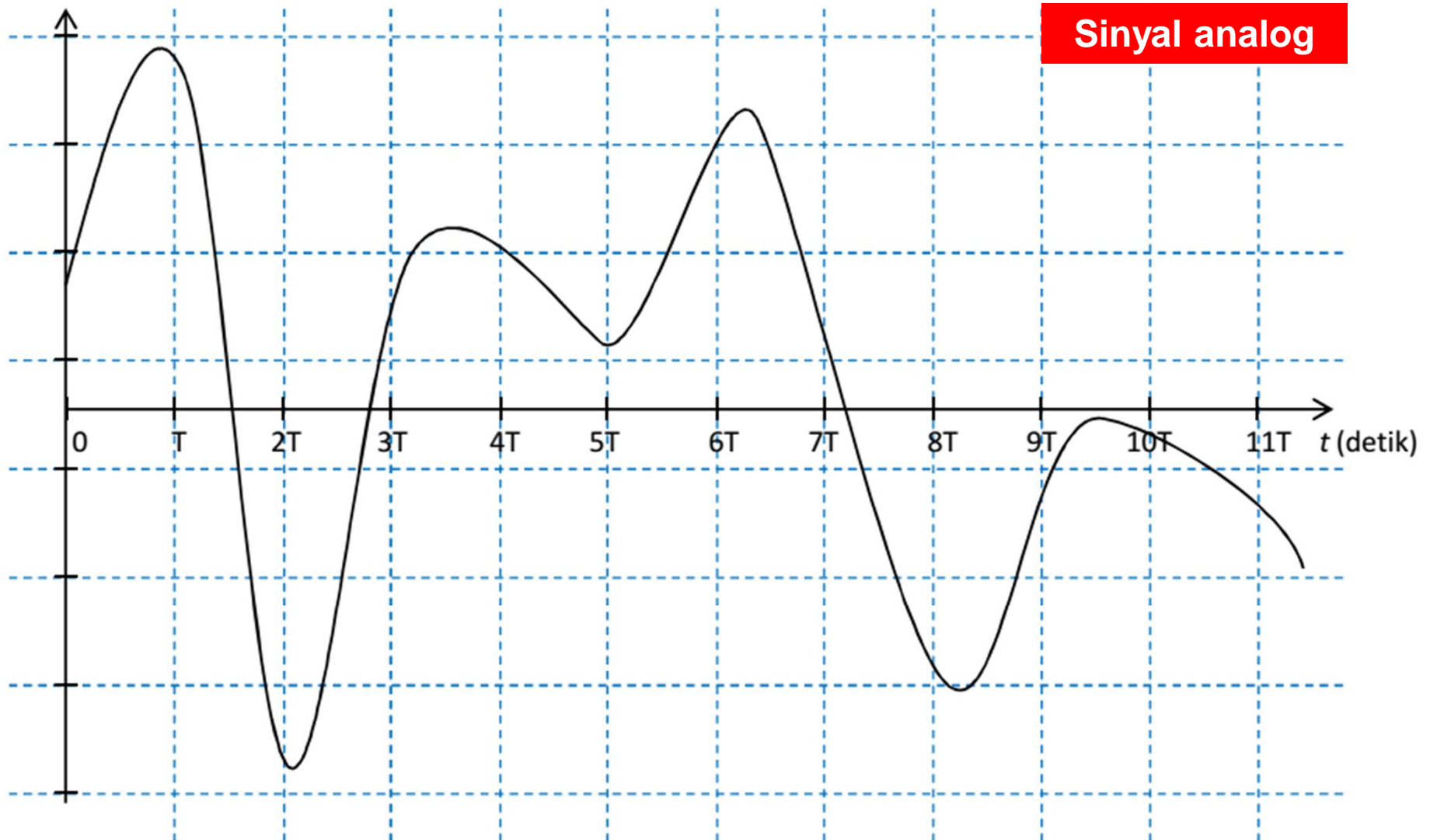



(i). Gambar ilustrasi sinyal hasil cuplikan:

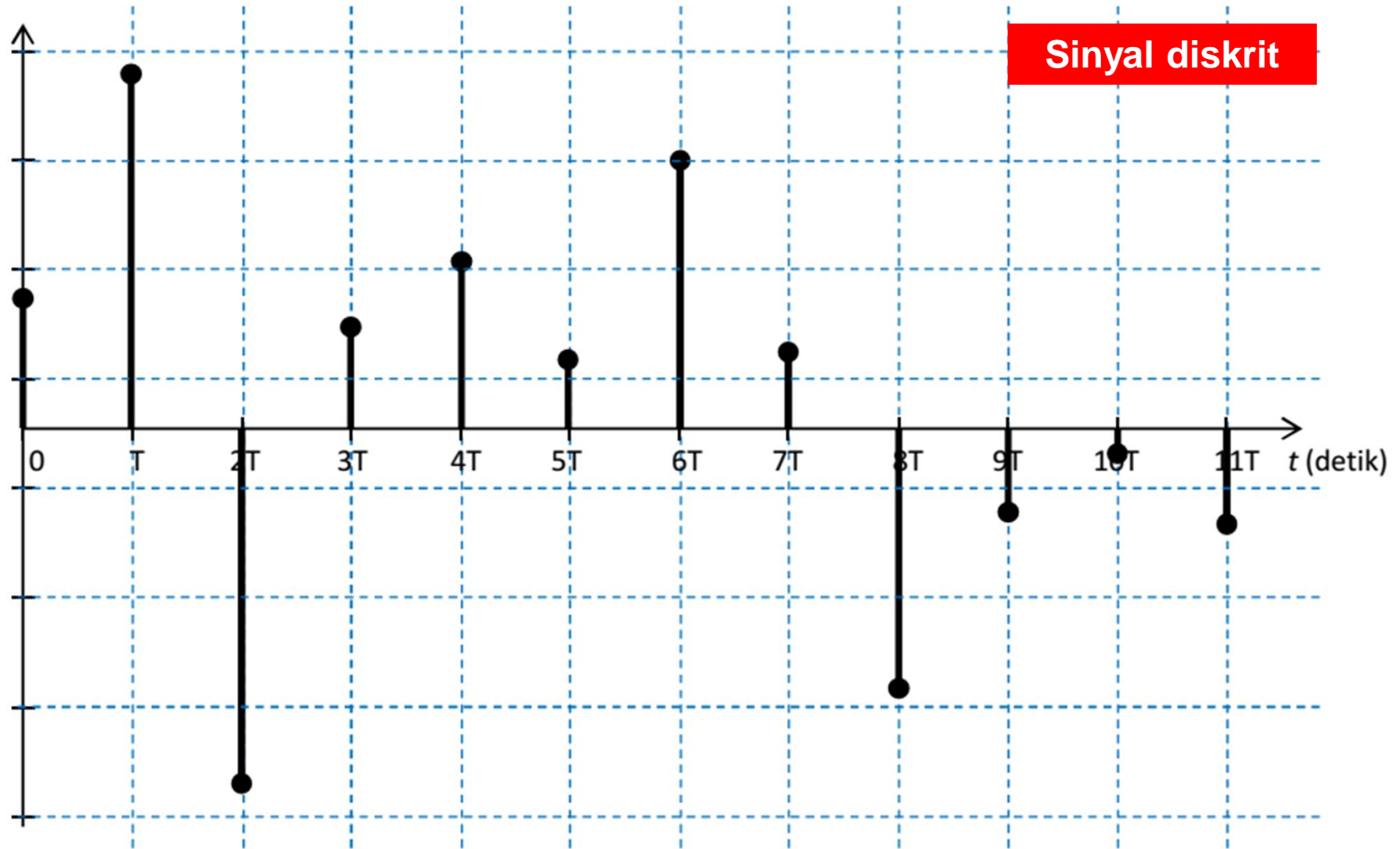



(ii). Gambar ilustrasi sinyal hasil kuantisasi:

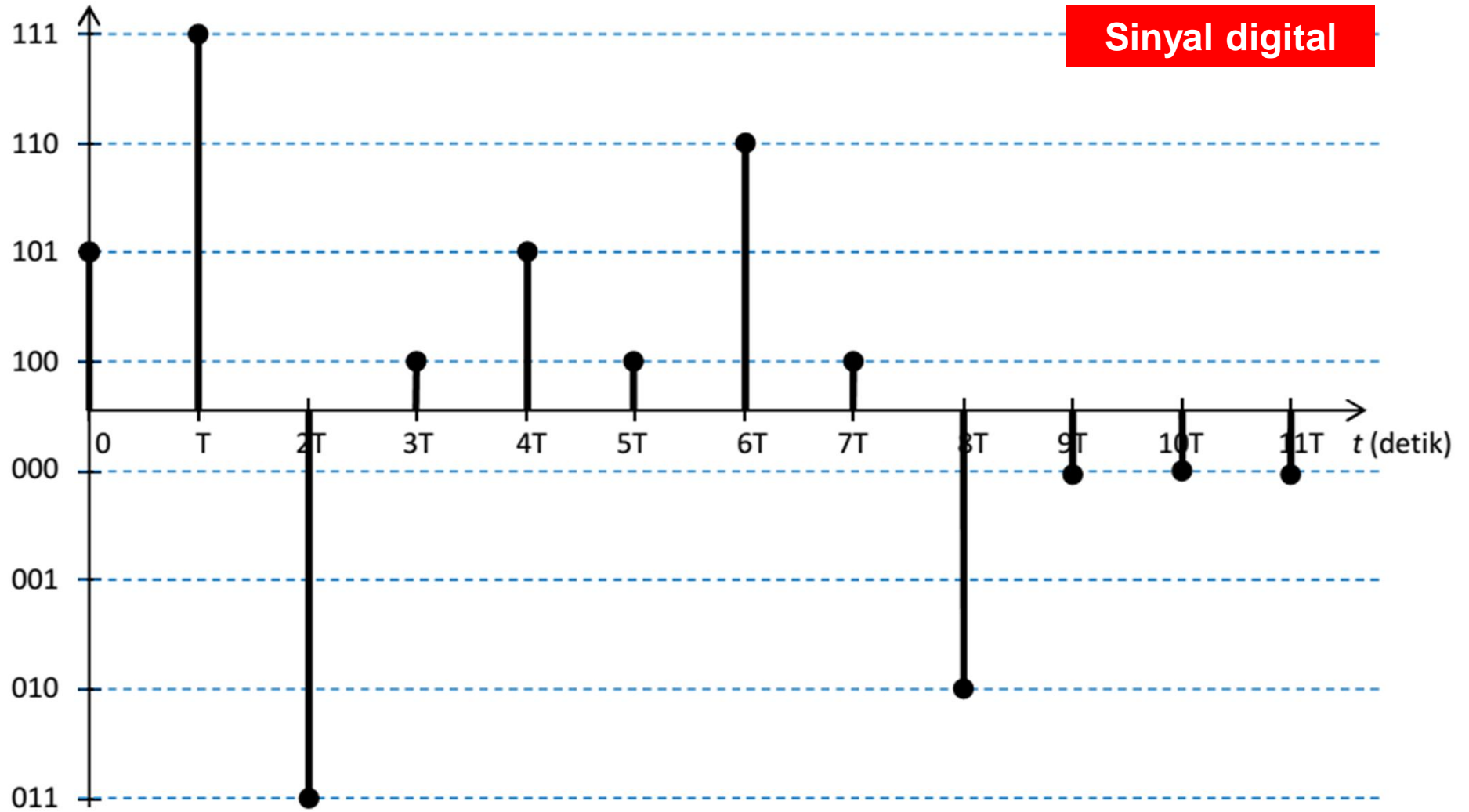



(iii). Hasil encode (*encoding*) utk setiap sampel adalah:

1. Sampel pada 0 detik adalah 101
2. Sampel pada T detik adalah 111
3. Sampel pada 2T detik adalah 011
4. Sampel pada 3T detik adalah 100
5. Sampel pada 4T detik adalah 101
6. Sampel pada 5T detik adalah 100
7. Sampel pada 6T detik adalah 110
8. Sampel pada 7T detik adalah 100
9. Sampel pada 8T detik adalah 010
10. Sampel pada 9T detik adalah 000
11. Sampel pada 10T detik adalah 000
12. Sampel pada 11T detik adalah 000

Sehingga deretan bit data PCM selengkapnya adalah 101111011100101100110100010000000000.

- (iv). Bila $T = 2,5 \times 10^{-4}$ detik, berarti **sampling rate** = $1/T$ Hz
= $1/(2,5 \times 10^{-4})$ Hz
= 4.000 Hz

yaitu ada 4.000 sampel tiap satu detik.

Sedangkan **data rate** = **sampling rate** x **jumlah bit per sampel**.

Oleh karena setiap sampel dikodekan menjadi 3 bit data, maka

$$\begin{aligned} \text{Data rate} &= 4000 \times 3 \text{ bit per sekon} \\ &= 12.000 \text{ bps} \end{aligned}$$

Sinyal biner

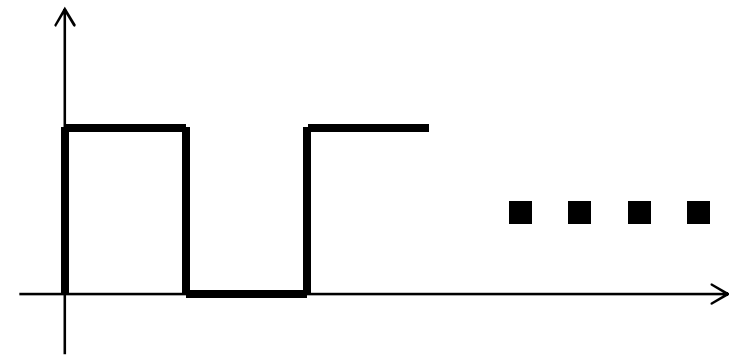



Signals in Communications

- Requirements of various applications
- Basics of Signal
- Characteristics of analog voice channels
- Fundamental differences between analog and digital signals
- Analog-to-digital conversion
- **Signal power**

Daya Sinyal

- Satuannya adalah **Watt**
- Ingat rumus: $P = V \times I$ atau $P = V^2/R$ atau $P = I^2 \times R$
- Satuan daya dpt juga dinyatakan secara logaritmik yaitu dgn **dBW** atau **dBm**, dimana daya aktual dibandingkan daya referensi 1 W atau 1 mW.
- Berikut ini adalah rumus-rumus untuk konversi dari satuan Watt ke dBW, satuan milliWatt ke dBm, dan sebaliknya.

Konversi dari Watt ke dB

- Rumus konversi dari satuan **Watt** ke satuan **dBW**:

$$P_{\text{dBW}} = 10 \cdot \log\left(\frac{P_{\text{Watt}}}{1 \text{ W}}\right) \text{ dBW}$$

- Rumus konversi dari satuan **mW** ke satuan **dBm**:

$$P_{\text{dBm}} = 10 \cdot \log\left(\frac{P_{\text{mW}}}{1 \text{ mW}}\right) \text{ dBm}$$

Ingat:

Sepanjang kuliah ini, $\log(x)$ adalah menyatakan logaritma berbasis 10 yaitu sama dengan $\log_{10}(x)$ atau ${}^{10}\log(x)$.

Konversi dari dB ke Watt

- Rumus konversi dari satuan **dBW** ke satuan **Watt** :

$$P_{\text{Watt}} = 10^{P_{\text{dBW}}/10} \text{ Watt}$$

- Rumus konversi dari satuan **dBm** ke satuan **mW** :

$$P_{\text{mW}} = 10^{P_{\text{dBm}}/10} \text{ mW}$$



Konversi dari dBW ke dBm

- Rumus konversi dari satuan **dBW** ke satuan **dBm** :

$$P_{\text{dBm}} = P_{\text{dBW}} + 30$$

- Rumus konversi dari satuan **dBm** ke satuan **dBW**:

$$P_{\text{dBW}} = P_{\text{dBm}} - 30$$



Power Loss vs. Power Gain

- Sinyal yg ditransmisikan melalui media apapun akan mengalami **penurunan daya** akibat redaman yg sebanding dgn jarak.
- Daya sinyal perlu dikontrol utk menjaga agar cukup tinggi dibandingkan *noise* ataupun cukup rendah utk menghindari *overload*.
- Penurunan daya sinyal (*loss* atau *attenuation*) dinyatakan dgn **power loss**. Sebaliknya, jika sinyal dikuatkan (oleh amplifier ataupun antena), dinyatakan dgn **power gain**.

Power Loss vs. Power Gain (2)

- **Penguatan (Gain)** absolut dinyatakan oleh

$$G = \frac{P_{out}}{P_{in}}$$

- Namun, *gain* lebih sering dinyatakan dlm ukuran logaritmik

$$G_{dB} = 10 \cdot \log G = 10 \cdot \log \left(\frac{P_{out}}{P_{in}} \right) \text{ dB}$$

- Dgn satuan **decibel (dB)** → utk mengenang jasa Alexander Graham Bell yg pertama menggunakan ukuran daya logaritmik.

Power Loss vs. Power Gain (2)



Gain

$$G = \frac{P_{out}}{P_{in}}$$

Gain in dB

$$G_{dB} = 10 \log \frac{P_{out}}{P_{in}}$$

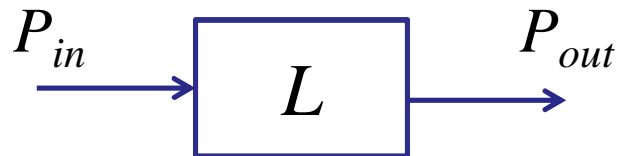

Loss

$$L = \frac{P_{in}}{P_{out}}$$

Loss in dB

$$G_{dB} = 10 \log \frac{P_{in}}{P_{out}}$$

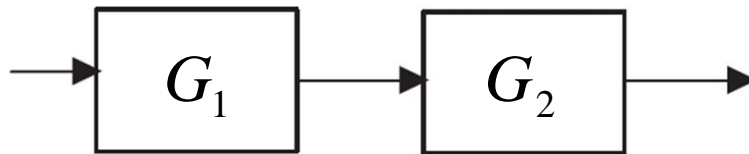

Overall gain:

$$G = G_1 \times G_2$$

Overall gain in dB: $G_{dB} = G_{1,dB} + G_{2,dB}$

For example, a gain of 100000000 corresponds to the gain of 80 dB



Contoh

Perhitungan Daya Sinyal (1)

$$1 \text{ W} = 10 \cdot \log\left(\frac{1 \text{ W}}{1 \text{ W}}\right) = 10 \cdot \log(1) = 10 \cdot 0 = 0 \text{ dBW}$$

$$1 \text{ W} = 10 \cdot \log\left(\frac{1000 \text{ mW}}{1 \text{ mW}}\right) = 10 \cdot \log(1000) = 10 \cdot 3 = 30 \text{ dBm}$$

$$1000 \text{ mW} = 10 \cdot \log\left(\frac{1000 \text{ mW}}{1 \text{ mW}}\right) = 10 \cdot \log(1000) = 10 \cdot 3 = 30 \text{ dBm}$$

$$10 \text{ W} = 10 \cdot \log\left(\frac{10 \text{ W}}{1 \text{ W}}\right) = 10 \cdot \log(10) = 10 \cdot 1 = 10 \text{ dBW}$$



Contoh

Perhitungan Daya Sinyal (2)

$$20 \text{ dBW} = 10^{20/10} = 10^2 = 100 \text{ Watt}$$

$$20 \text{ dBm} = 10^{20/10} = 10^2 = 100 \text{ mW}$$

$$20 \text{ dB} = 10^{20/10} = 10^2 = 100$$

$$20 \text{ dBW} = 20 + 30 = 50 \text{ dBm}$$

$$20 \text{ dBm} = 20 - 30 = -10 \text{ dBW}$$

Ingat, ada tiga macam satuan decibel: **dBW**, **dBm**, dan **dB**



Cara Sederhana Menghitung dB

Numerik	Logaritmik
10^{-5}	-50 dB
10^{-4}	-40 dB
10^{-3}	-30 dB
10^{-2}	-20 dB
10^{-1}	-10 dB
10^0	0 dB
10^1	10 dB
10^2	20 dB
10^3	30 dB
10^4	40 dB
10^5	50 dB

Cara Sederhana Menghitung dB (2)

Numerik	Logaritmik
1	0 dB
2	3,01 dB
3	4,77 dB
4	6,02 dB
5	6,99 dB
6	7,78 dB
7	8,45 dB
8	9,03 dB
9	9,54 dB
10	10 dB

Yang penting utk diingat adalah:

$$2 = 3,01 \text{ dB} \approx 3 \text{ dB} \quad \text{dan} \quad 10 = 10 \text{ dB}$$

Cara Sederhana Menghitung dB (3)

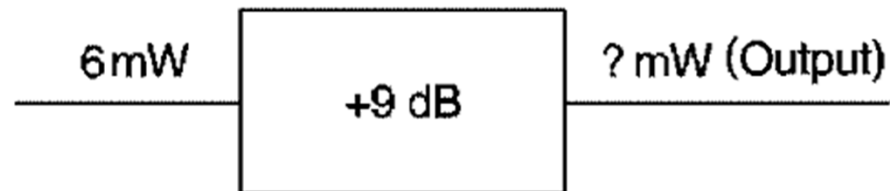

=

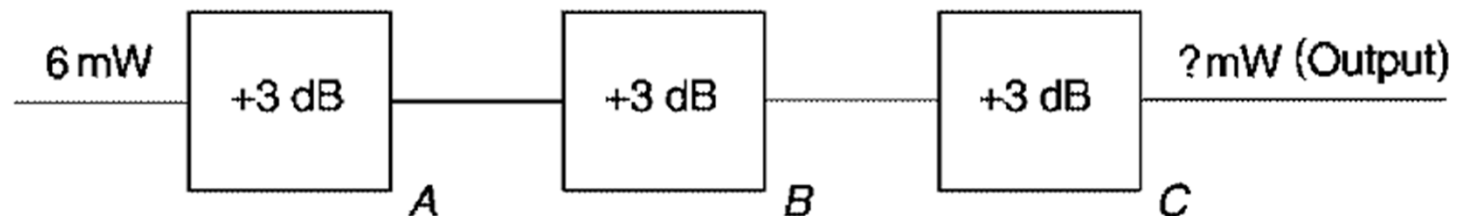

$$9 \text{ dB} = 3 \text{ dB} + 3 \text{ dB} + 3 \text{ dB} = 2 \times 2 \times 2 = 8$$

$$\text{Maka: Output} = 6 \text{ mW} \times 8 = \mathbf{48 \text{ mW}}$$

Cara Sederhana Menghitung dB (4)

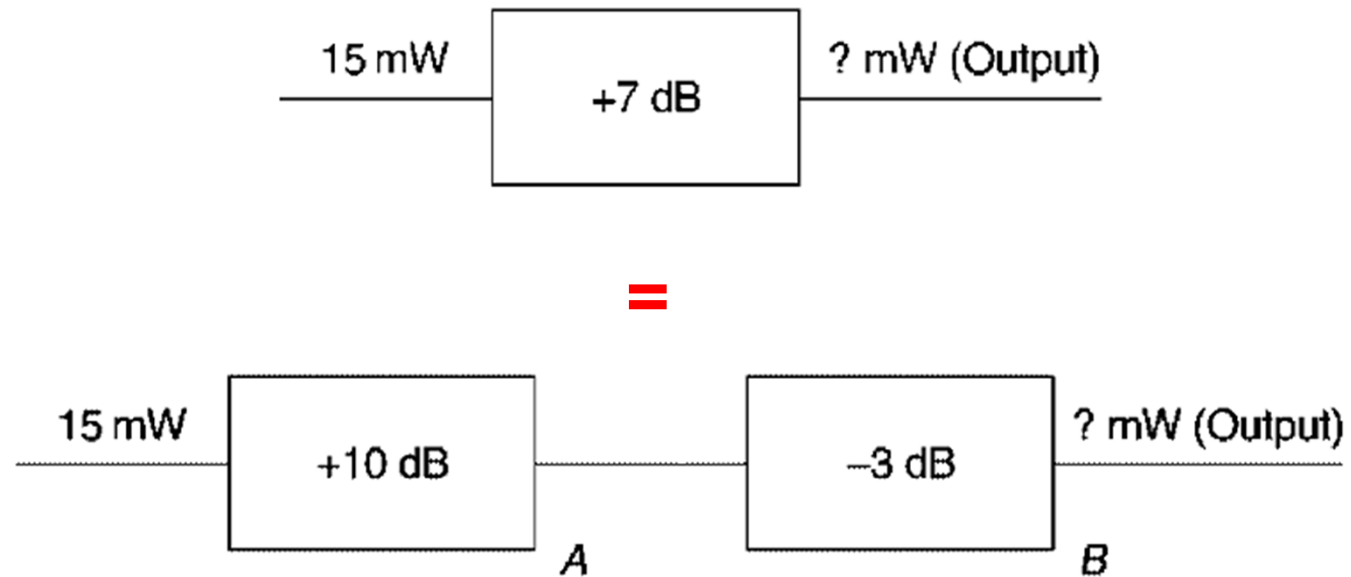

$$7 \text{ dB} = 10 \text{ dB} - 3 \text{ dB} = 10 / 2 = 5$$

$$\text{Maka: Output} = 15 \text{ mW} \times 5 = \mathbf{75 \text{ mW}}$$

Cara Sederhana Menghitung dB (5)

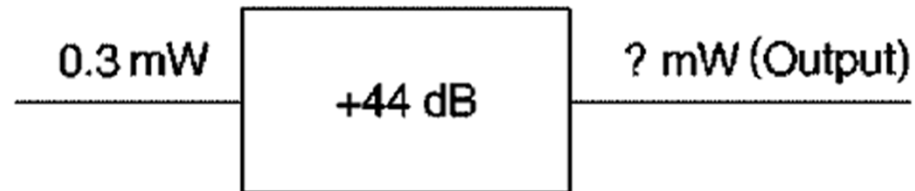

=

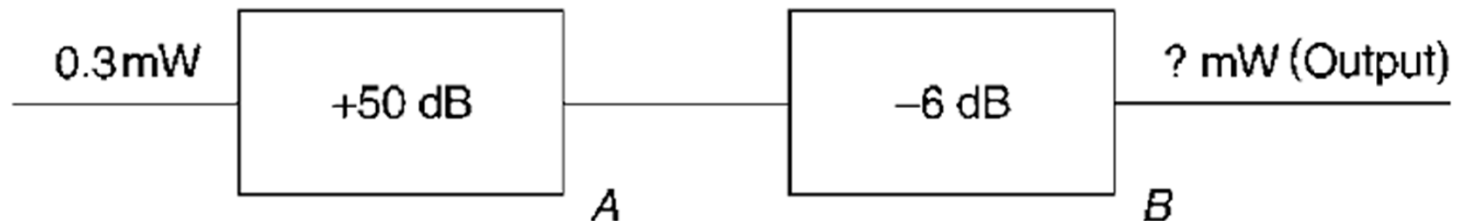

$$\begin{aligned} 44 \text{ dB} &= 50 \text{ dB} - 6 \text{ dB} = 50 \text{ dB} - (3 \text{ dB} + 3 \text{ dB}) \\ &= 100.000 / (2 \times 2) = 100.000 / 4 \\ &= 25.000 \end{aligned}$$

$$\text{Maka: Output} = 0,3 \text{ mW} \times 25.000 = \mathbf{7.500 \text{ mW}}$$

PR-4

- Soal-soal PR-4 ada di file tersendiri.

Latihan di Kelas

- 1). Untuk kedua sinyal sinusoidal berikut ini, **tuliskan persamaan** masing-masing dan **gambaran bentuk gelombangnya**:
 - a) Sinyal tegangan AC dgn amplitudo 2 volt, frekuensi 1 kHz, dan fase 0 radian.
 - b) Sinyal tegangan AC dgn amplitudo 3 volt, frekuensi 2 kHz, dan fase $\mu/2$ radian.

Catatan: Gunakan fungsi sinus!

- 2). Gambarkan ilustrasi spektrum $|V(t)|$ dari kedua sinyal tersebut!

Penyelesaian

1). Persamaan dan Bentuk Gelombang

Persamaannya:

a).

b).

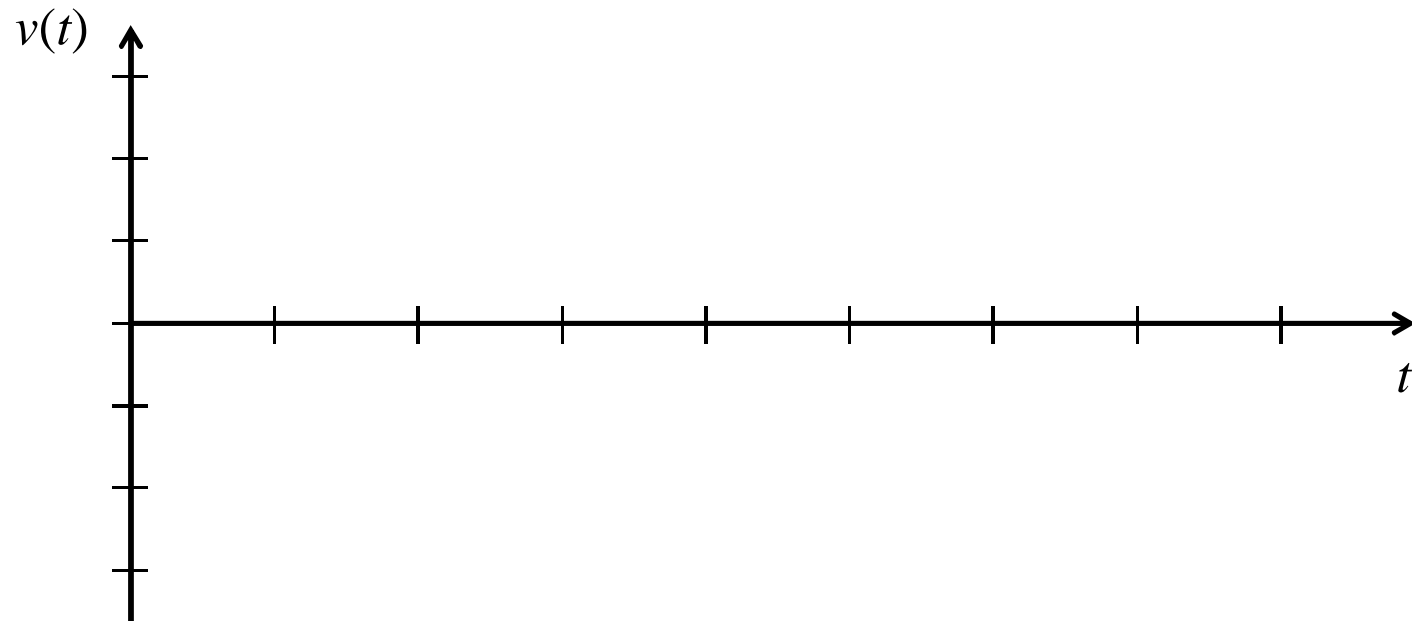



2). Spektrum

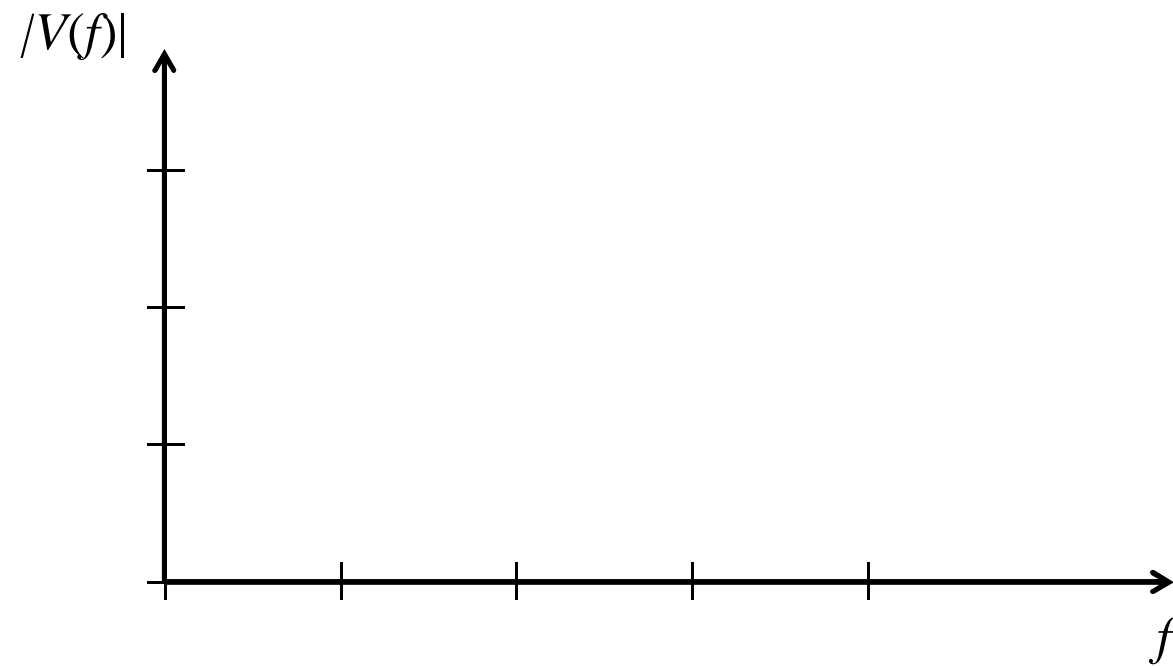



Sekian, terima kasih, semoga berkah.

Ada pertanyaan?