

universitas  
MALIKUSSALEH

# Pertemuan 3

# Sistem Komunikasi Bergerak ( Cellular )

Dahlan Abdullah  
dahlan@unimal.ac.id  
<http://www.dahlan.web.id>

# PLMN

**Jaringan seluler atau PLMN (public line mobile network) terdiri dari sejumlah mobile station (MS) yang dihubungkan dengan jaringan radio ke infrastruktur perangkat switching yang berinterkoneksi dengan sistem lain seperti PSTN**

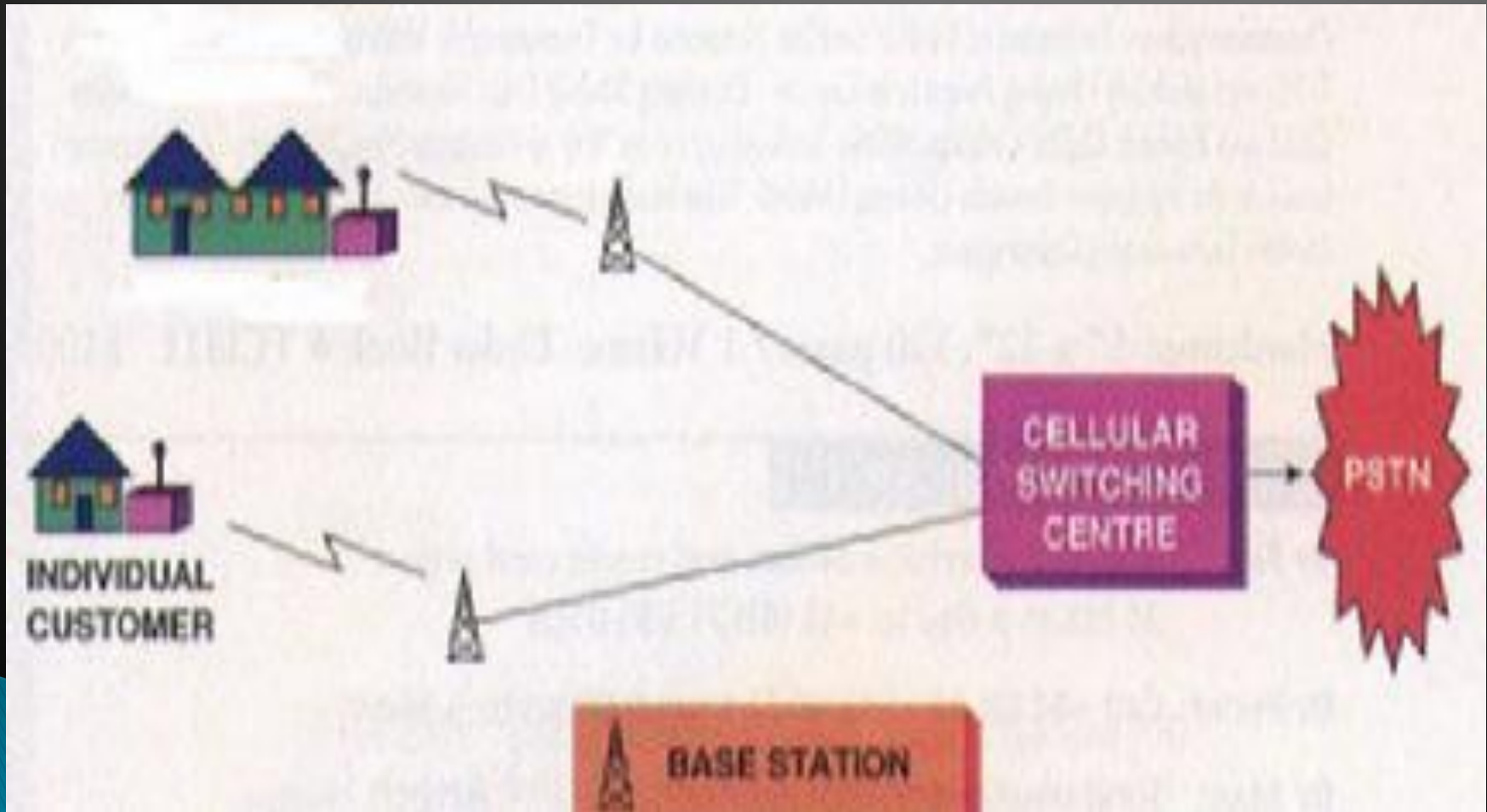

# Perbandingan PSTN dan PLMN

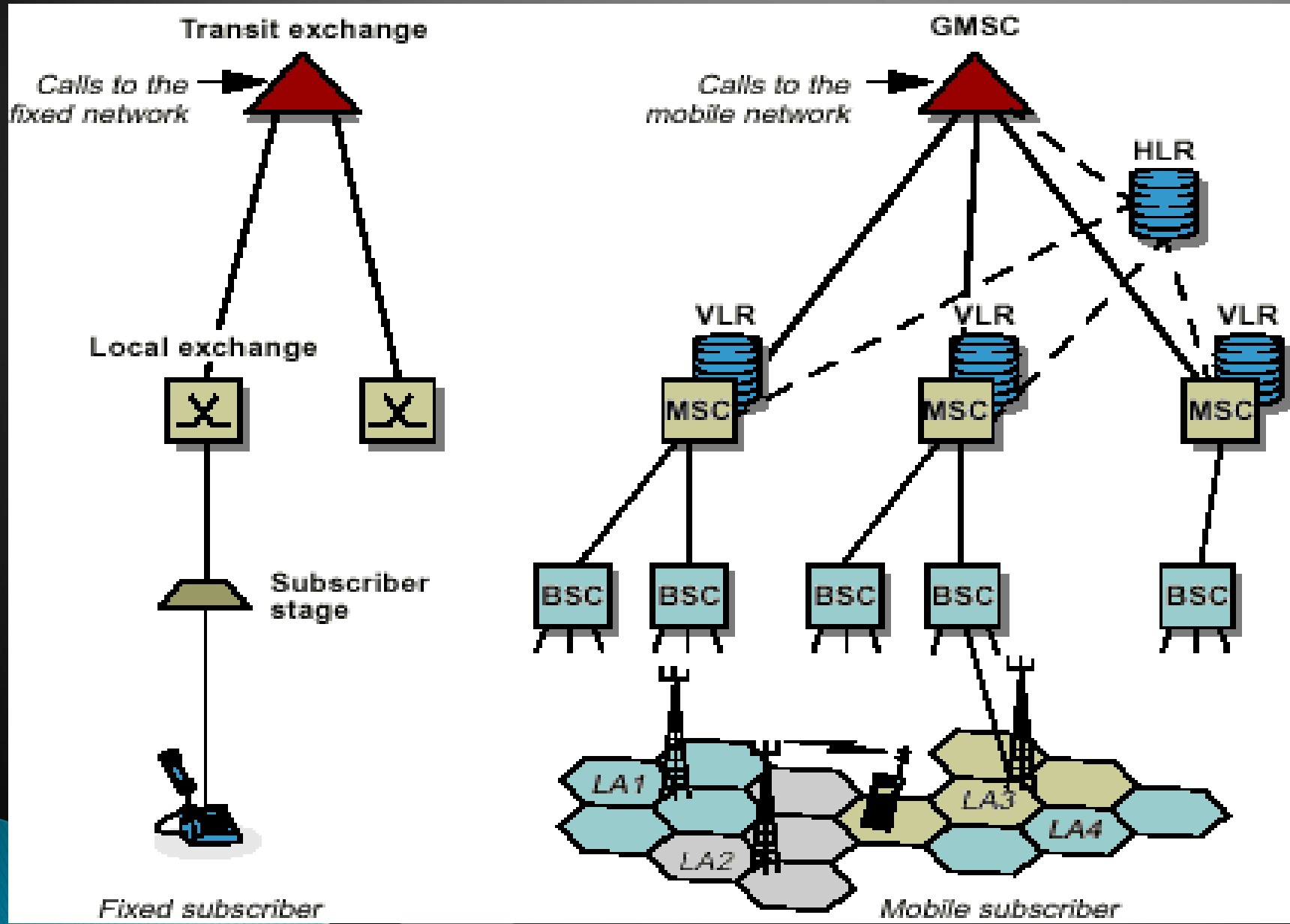

# Klasifikasi WIRELESS

<b>Wireless Communication</b>	<b>Fixed Wireless</b>	<b>Non Cellular</b>	<b>contoh :</b> point to point communication, infra red communication, LMDS, Microwave communication
		<b>Cellular</b>	<b>contoh :</b>  PHS, CT2, PACS, DCS1800, DECT
	<b>Mobile Wireless</b>	<b>Non Cellular</b>	<b>contoh :</b> paging system (ERMES, NTT, NEC) , dispatching system, PAMR ( <i>Public Access Mobile Radio</i> ) dsb
		<b>Cellular</b>	<b>contoh :</b>  GSM, CDMA/IS-95, AMPS, UMTS, PHS, DCS1800, NMT450, TACS, C-450, dsb

# WIRELESS COMMUNICATION CONCEPT

HUBUNGAN DARI SENTRAL KEPELANGGAN DILAKUKAN MELALUI RADIO DAN BUKAN KABEL

- SARANA TRANSMISI SELAIN TELEPON LEWAT KABEL ( PSTN )
- MEMPERCEPAT PELAYANAN KARENA TIDAK TERGANTUNG PADA INSTALASI DAN MAINTENANCE KABEL .
- FLEXIBILITAS DALAM PERGERAKAN DAN FEATURES YANG LEBIH BAIK.
- PENGGUNAAN KOMPRESI DIGITAL MENGEFEKTIFKAN SALURAN.
- KECEPATAN ALIRAN BIT RELATIF KECIL UNTUK PENGGUNAAN RADIO DENGAN FREKUENSI RENDAH.

# Early Mobile Systems

Layanan mobile tradisional dibangun mirip dengan televisi broadcasting

Satu pemancar dengan daya yang besar ditempatkan pada titik yang paling tinggi yang dapat meliputi area dengan radius sampai dengan 50 km

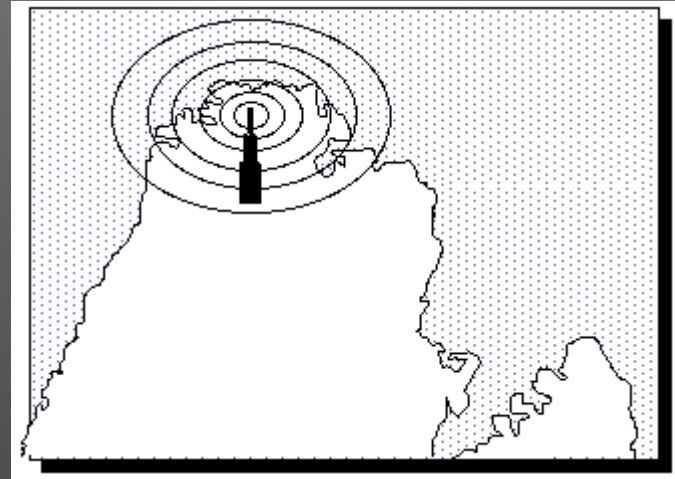

Konsep seluler Cellular dibentuk dari jaringan telepon mobile dengan cara: menggunakan daya pancar yang rendah untuk mencakup area yang lebih luas → contoh area metropolitan dibagi ke dalam 100 sel yang berbeda dimana masing-masing sel dgn 12 kanal

# Early Mobile Systems

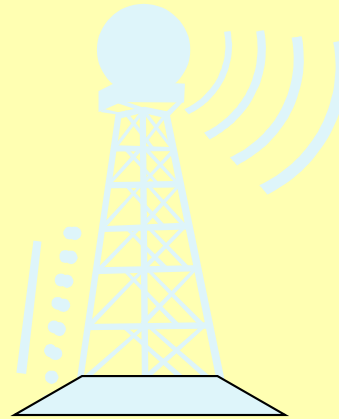

- **Early Mobile Radio Systems**

- Satu pemancar dengan daya pancar yang besar
- Area cakupan yang bagus, tetapi tidak memungkinkan dilakukan penggunaan ulang ( reuse) frekuensi yang sama (e.g., Bell Mobile System '70 -- max 12 calls over thousand sq. Miles)

# Cellular Systems

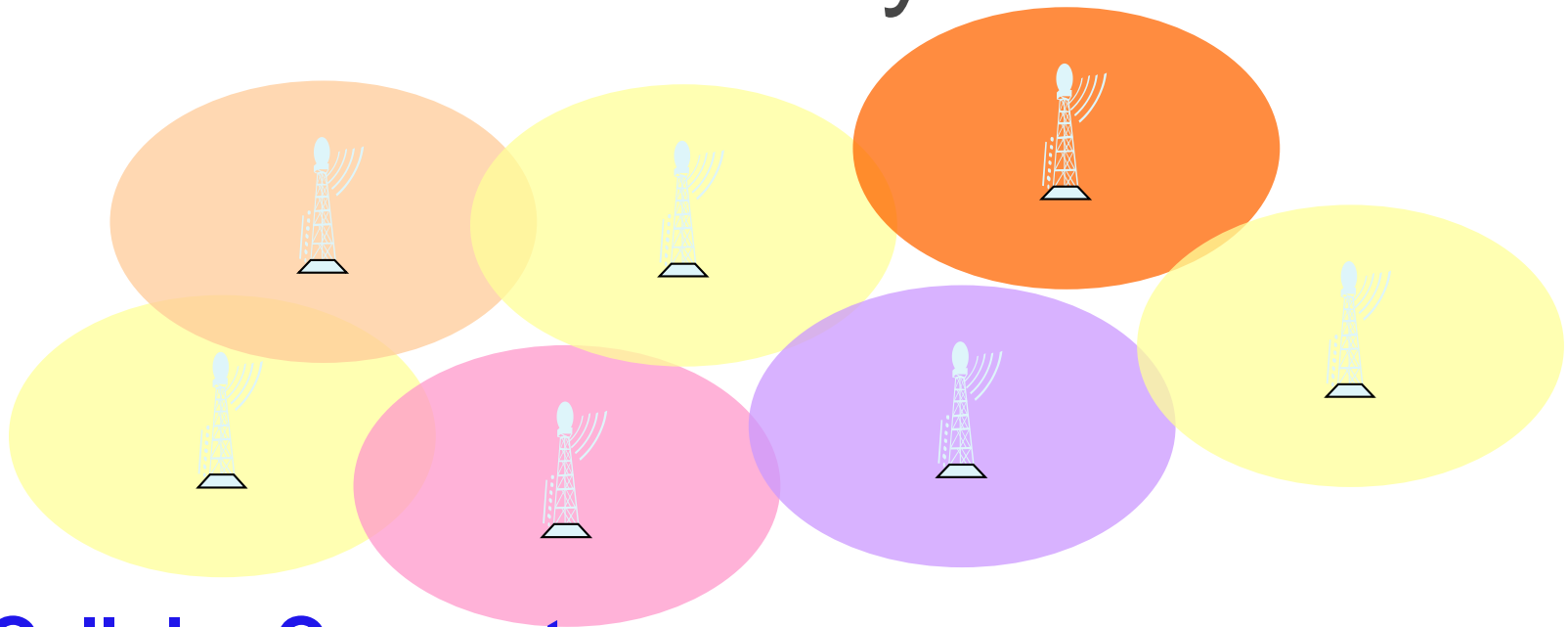

- **Cellular Concept**

- technique of using a fixed a number of channels to serve an arbitrary large number of subscribers by reusing channels throughout the coverage area
- high system capacity in a limited spectrum
- many low powered transmitters (small cells)
- each base station allocated a portion of the spectrum
- neighboring base stations assigned different groups of channels



# Cellular Systems

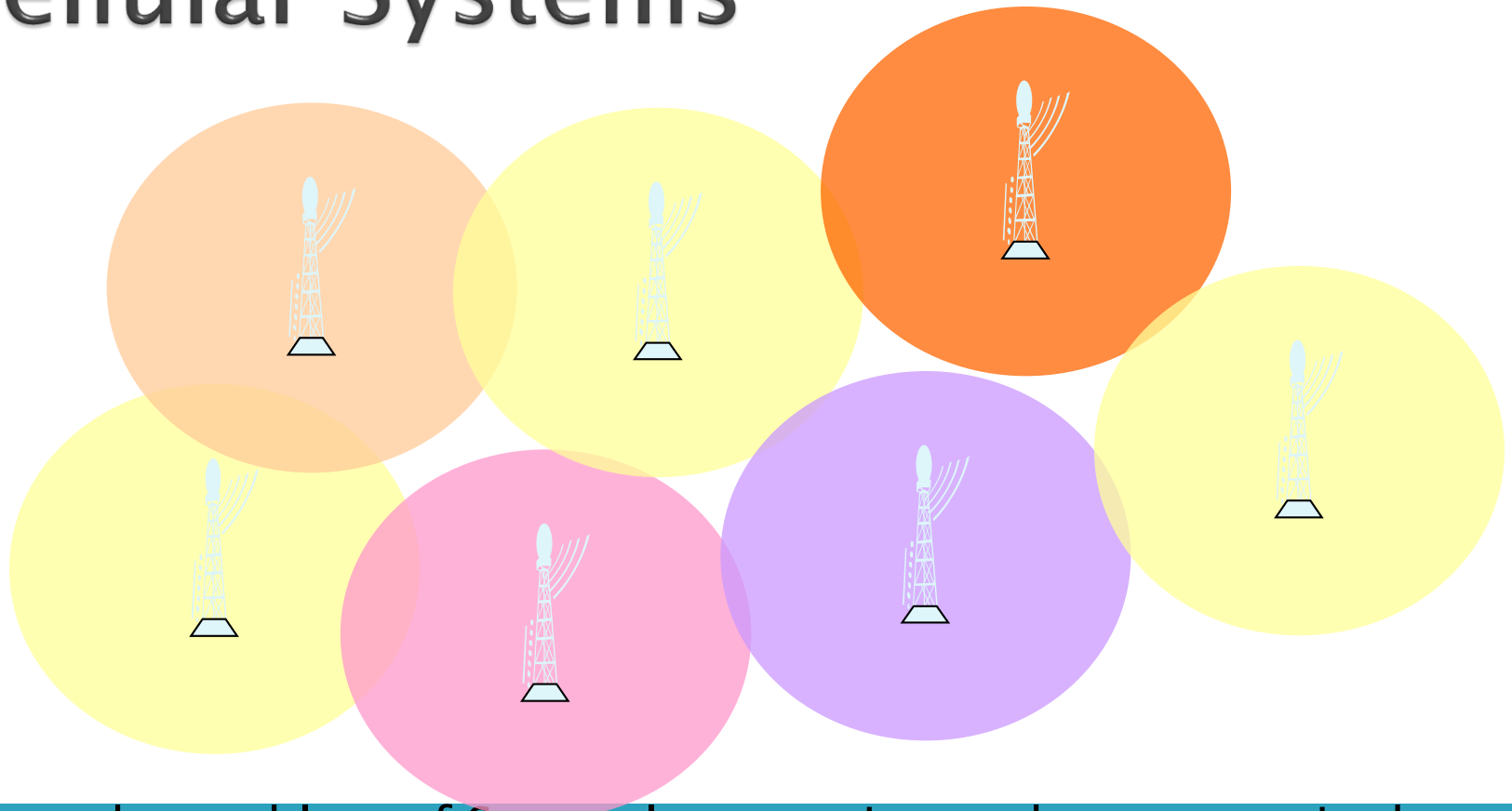

Solves the problem of Spectral congestion and user capacity by means of **frequency reuse**

Offers high capacity in a limited spectrum allocation

Offers system level approach, using low power transmitters instead of a single, high power transmitter (large cell) to cover larger area.

A portion of the total channels available is allocated to each base station.

Neighbouring base stations are assigned different groups channels, in order to minimise interference.

# Model pola radiasi

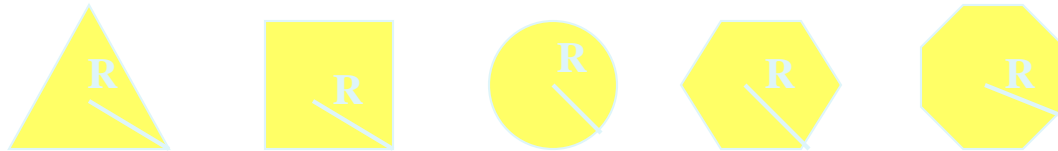

- **Model radiasi mana yang paling bagus ?**

# DEFINISI.

Sistem komunikasi yang digunakan untuk memberikan layanan jasa telekomunikasi bagi pelanggan bergerak.

Disebut sistem cellular karena daerah layanannya dibagi-bagi menjadi daerah yang kecil-kecil yang disebut **CELL**.

**SIFAT** : Pelanggan mampu bergerak secara bebas di dalam area layanan sambil berkomunikasi tanpa terjadi pemutusan hubungan.

# Cluster 7 sel

Cluster size  
is expressed as  $n$   
In this cluster  $n=7$

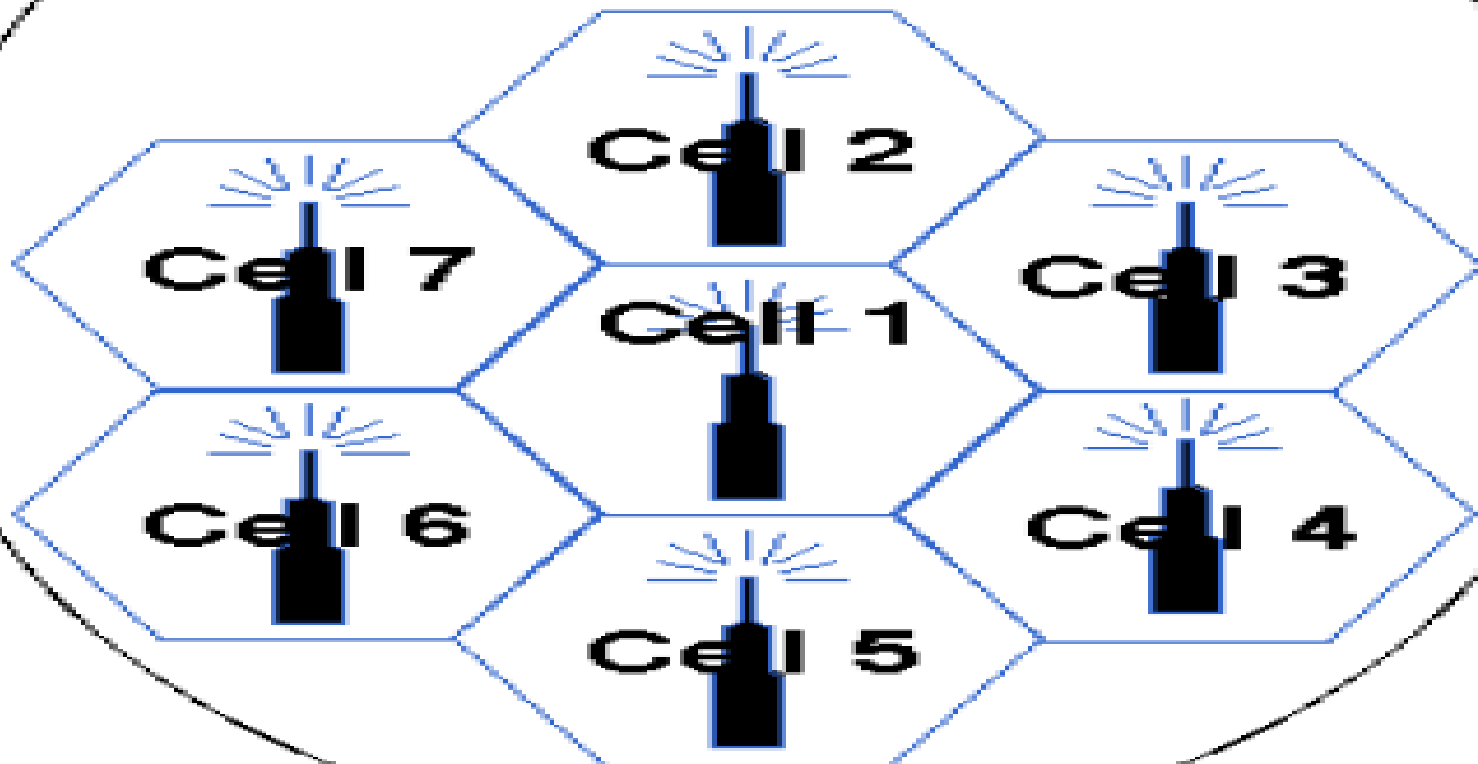

# Jaringan Layanan telepon bergerak dasar

- MELAKUKAN PENYAMBUNGAN ANTAR MS DAN MS KE PSTN
- SISTEM CELLULAR TIDAK TERIKAT PADA HIRARCHI KARENA SEMUA MS BERHUBUNGAN LANGSUNG DENGAN MSC. (SECONDARY)
- MELAKUKAN PROSES PENGENDALIAN AKTIVITAS BTS DAN MS.
  - HAND OVER ( HARD / SOFT )
  - ROAMING
  - PENGAJARAN LEVEL PANCAR MS
  - KOORDINASI ANTARA CELL
- PROSES PENGENDALIAN TERSEBUT DILAKUKAN DENGAN KOMANDO LEWAT KANAL DATA.

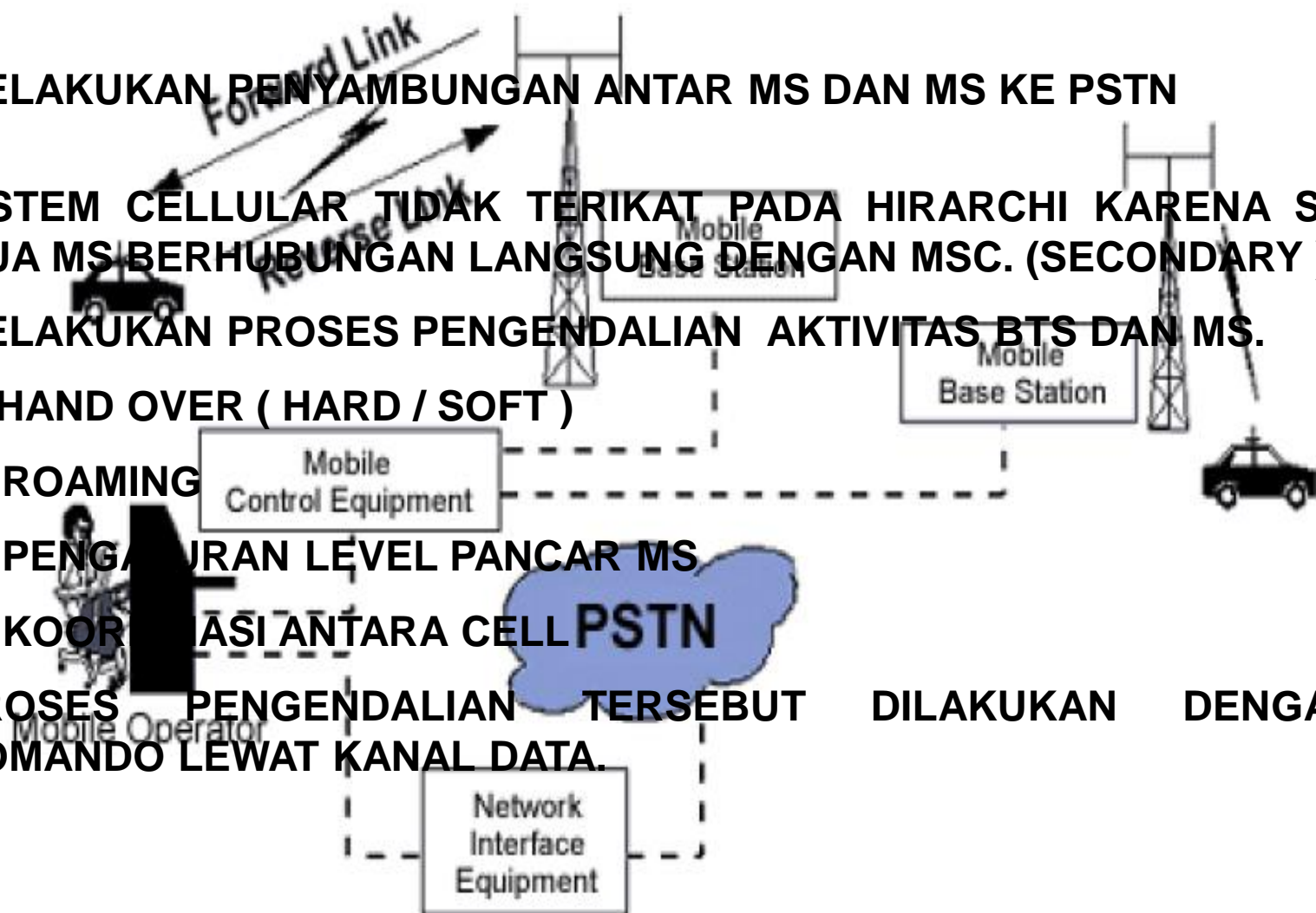

# CONCEPT OF CELLULAR TELEPHONE

- **MSC INTI SYS. CELLULAR**
- **MSC DIHUBUNG DENGAN PSTN.**
- **AREA DIBAGI – BAGI DALAM CELL KECIL (1 – 12 KM)**
- **KOMPONEN DASAR CELLUAR ADALAH : CELL, MSC DAN UNIT BERGERAK (MS).**

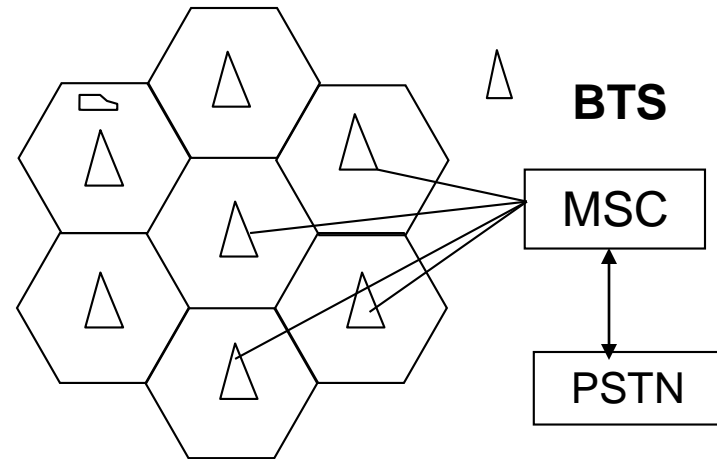

- **MSC MENGENDALIKAN SEMUA AKTIVITAS HUBUNGAN LEWAT BTS.**
- **MS BERHUBUNGAN DENGAN MSC MELALUI BTS YANG TERDEKAT (BAIK SECARA TETAP ATAU BERGERAK).**
- **PELANGGAN DAPAT BERPINDAH DENGAN BEBAS DARI SATU CELL KE CELL YANG LAIN.**
- **PADA PERPINDAHAN HARUS TERJADI PROSES HAND OVER**
- **PELANGGAN DAPAT DICARI ( ROAMING ) MELALUI KOORDINASI ANTARA MSC – BTS ATAU MSC – MSC.**

# BTS

- **TINGGI MENARA ANTARA 15 – 92 M TERGANTUNG PADA KONDISI LINGKUNGAN DAERAHNYA.**
  - **POWER PANCAR EFEKTIF MAKSIMUM 100 WATT.**
  - **ANTENA YANG DIGUNAKAN DALAM SATU SELL DAPAT LEBIH DARI SATU (SEKTORISASI)**
  - **PADA BTS TERSEDIA COMBINER UNTUK MEHUBUNGAN BEBERAPA PEMANCAR PADA ANTENA.**
  - **ANTARA BTS DENGAN MSC DIHUBUNGAN DENGAN MICROWAVE ATAU KABEL DENGAN SALURAN BER KECEPATAN 2 MBPS.**
  - **BTS HANYA MENYALURKAN INFORMASI DARI MS KE MSC ATAU SEBALIKNYA.**
  - **POWER PANCAR SATU BTS MENENTUKAN LEBAR CAKUPAN SEBUAH CELL.**
  - **UNTUK MENCAKUP MS DALAM GEDUNG DIGUNAKAN CELL YANG SANGAT KECIL (MICRO CELL)**
- 

# MOBILE STATION

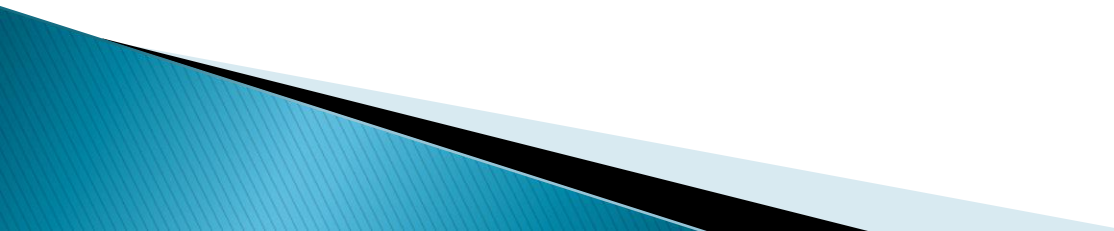
- ▶ TERDIRI DARI UNIT KONTROL, TRANCEIVER RADIO DAN ANTENA.
  - ▶ UNIT KONTROL TERDIRI DARI PERANGKAT TELEPON, TOMBOL – TOMBOL, INDIKASI AUDIO / VISUAL UNTUK MENUNJUKAN PROSES PENYAMBUNGAN.
  - ▶ TRANSCEIVER MELAKUKAN TRANSMISI DUPLEX KE BTS
  - ▶ GAIN ANTENA MS YANG DIGUNAKAN RATA – RATA 2 dB.
  - ▶ POWER PANCAR RATA – RATA 23 dBm ( TERGANTUNG PADA JARAK MS KE BTS ).
  - ▶ PADA SAAT IDLE MAKA MS BERADA PADA KANAL KONTROL BTS.
  - ▶ MS DAPAT MERUBAH – RUBAH FREKUENSI YANG DIGUNAKAN UNTUK DISESUAIKAN DENGAN SALAH SATU FREKUENSI BTS.
- 



# FREKUENSI

- ▶ FREKUENSI YANG DIGUNAKAN PADA BAND 800, 900 DAN 1800 MHZ
- ▶ LEBAR FREKUENSI PADA TIAP BAND 25 MHZ.
- ▶ FREKUENSI REUSE DIGUNAKAN KARENA :
  - PITA FREKUENSI YANG TERSEDIA TERBATAS.
  - POWER TRANCEIVER MS TERBATAS.
  - PELANGGAN YANG BANYAK DAN TERSEBAR.
- ▶ MASALAH FREKUENSI REUSE ADALAH:
  - INTERFERENSI
  - AKSES MS KE BTS.
  - PENGATURAN LEBAR CELL.
  - PENGATURAN FREKUENSI DALAM SATU CELL.
  - PENGATURAN LEVEL TRANSMIT BTS.
- ▶ JUMLAH KANAL / SLOT TIAP SEL ANTARA 10 – 50 BUAH TERGANTUNG KEPADATAN TRAFFIC SEL TERSEBUT.

# AKSES MS KE BTS

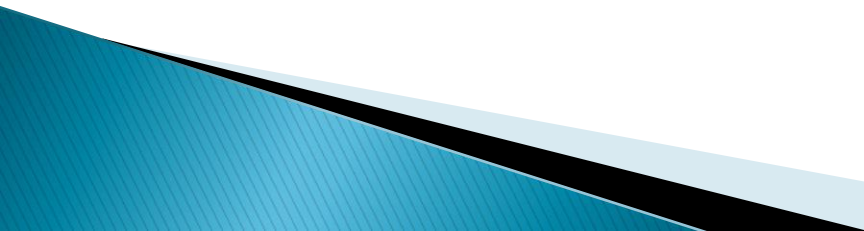
- ▶ **FDMA ( FREKUENSI DIVISION MULTIPLE ACCESS)**
    - PEMBEDAAN ANTARA SATU SALURAN DENGAN SALURAN YANG LAIN DILAKUKAN DENGAN PEMBEDAAN FREKUENSI.
  
  - ▶ **TDMA ( TIME DIVISION MULTIPLE ACCESS)**
    - PEMBEDAAN ANTARA SATU KANAL DENGAN KANAL YANG LAIN DILAKUKAN DENGAN PEMBEDAAN WAKTU (PENJADWALAN) → SLOT.
    - DAPAT SAJA DILAKUKAN AKSES DENGAN CARA TDMA / FDMA.  
*SATU FREKUENSI ( FDMA) MENYALURKAN BEBERAPA SLOT (TDMA)*
  
  - ▶ **CDMA ( CODE DIVISION MULTIPLE ACCESS)**
    - AKSES OLEH MS DILAKUKAN PADA WAKTU DAN FREKUENSI YANG SAMA.
    - PEMBEDAAN DILAKUKAN HANYA DALAM PENGKODEAN.
- 

# Karakteristik dasar System Cellular

- ▶ Frekuensi Re-use
  - ▶ Cell Splitting
  - ▶ Handover
- 

# Frequency Reuse

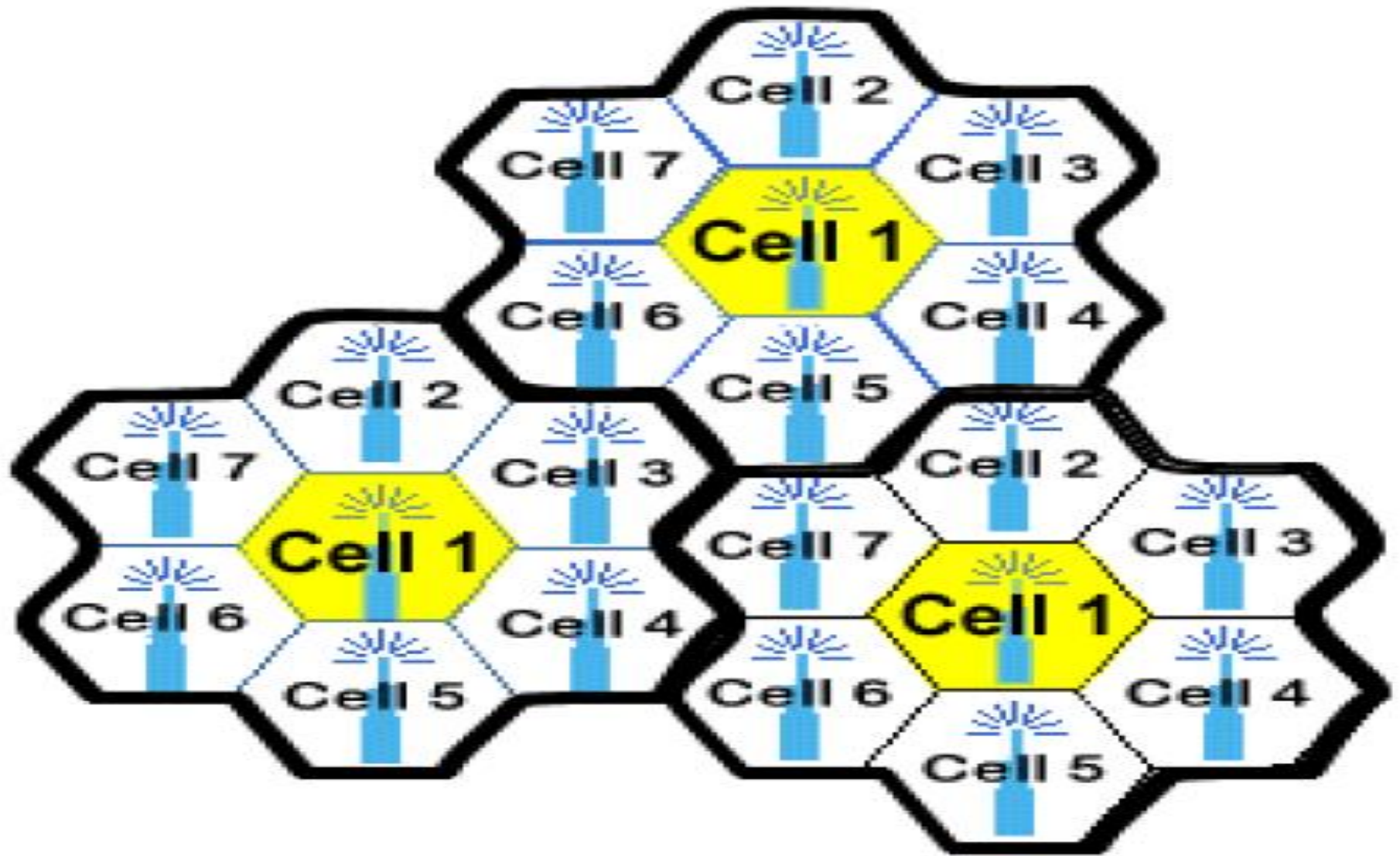

# Cell Splitting

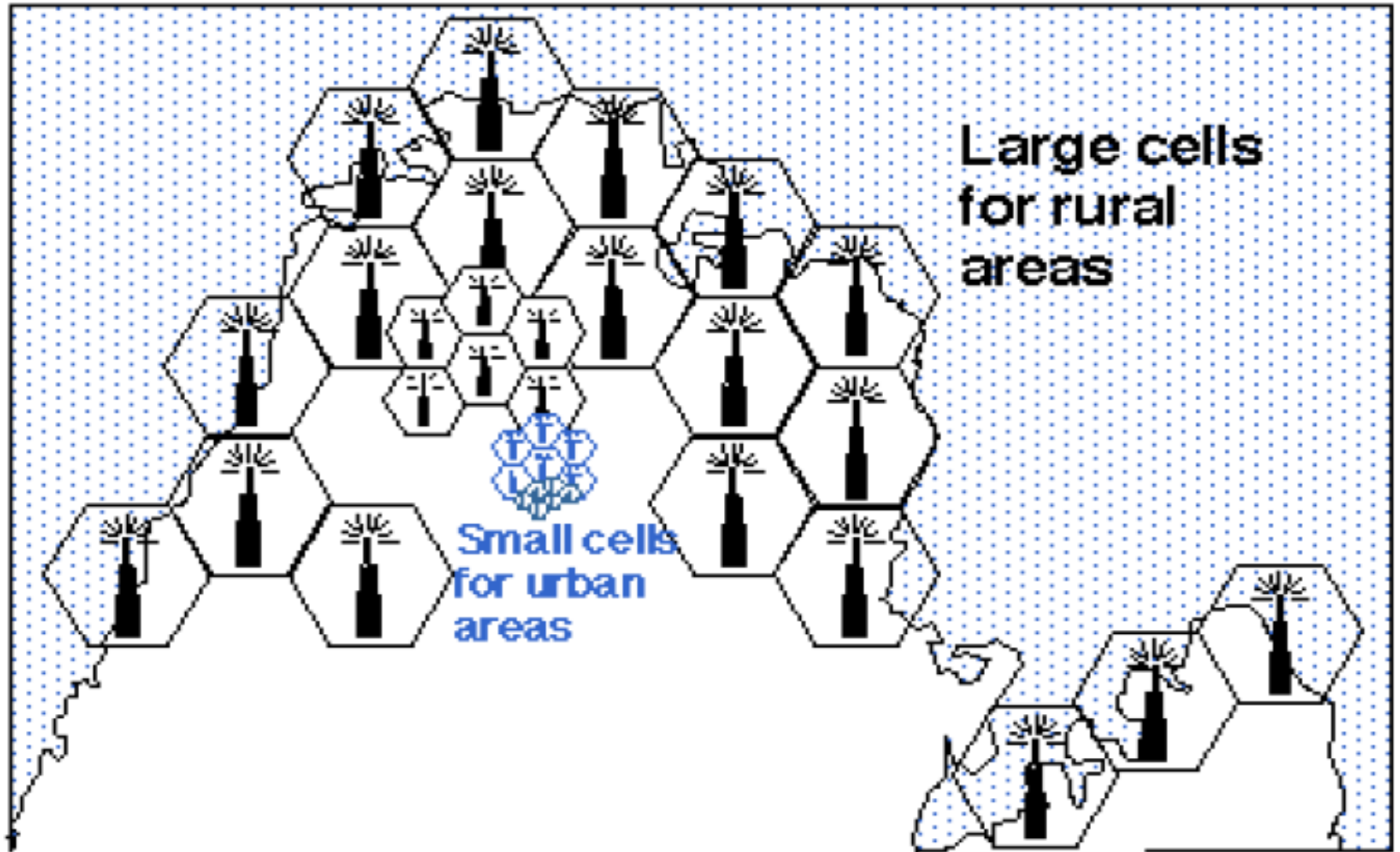

# Handoff antar Sel Bersebelahan

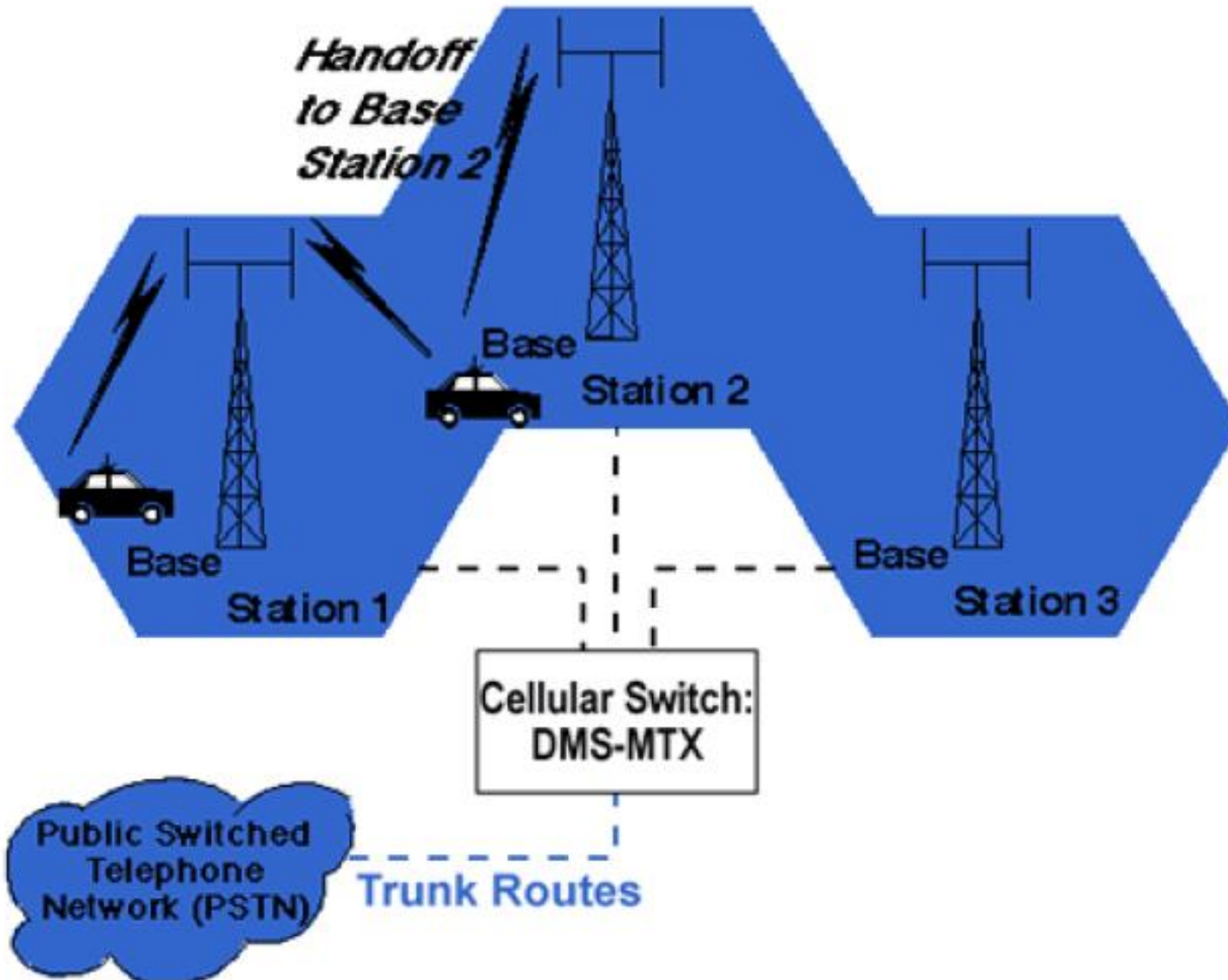

# Standar Sistem Seluler

## Sistem Seluler Analog – Generasi Pertama

- ❖ AMPS ( Advanced Mobile Phone System )
- ❖ NMT 450 ( Nordic Mobile Phone )
- ❖ TACS ( Total Access Communication System )

## Sistem Seluler Digital – Generasi Kedua

- ❖ GSM ( Global System for Mobile Communication )
- ❖ DAMPS ( Digital AMPS )
- ❖ CDMA/IS-95

## Generasi Ketiga

- ❖ IMT 2000

# Technology Cellular.



**1G**  
wireless

**AMPS** (Advanced Mobile Phone Service)

- Analog voice service
- No data service

**2G**  
wireless

**CDMA** (Code Division Multiple Access)  
**TDMA** (Time Division Multiple Access)  
**GSM**  
(Global System for Mobile  
Communications)  
**PDC** (Personal Digital Cellular)

- Digital voice service
- 9.6K to 14.4K bit/sec.
- CDMA, TDMA and PDC offer one-way data transmissions only
- Enhanced calling features like caller ID
- No always-on data connection

**3G**  
wireless

**W-CDMA**  
(Wide-band Code Division Multiple  
Access)

**CDMA-2000**

- Superior voice quality
- Up to 2M bit/sec.
- always-on data
- Broadband data services like video & multimedia
- Enhanced roaming



# Perbandingan

	<b>AMPS</b>	<b>GSM</b>	<b>CDMA/IS-95</b>
<b>Akses jamak</b>	FDMA	TDMA	DS-CDMA
<b>Modulasi</b>	FM	GMSK	QPSK
<b>Bandwidth RF</b>	30 kHz	200 kHz	1,25 MHz
<b>Kanal / carrier RF</b>	1	8	20 – 30
<b>Frekuensi Uplink</b>	824 – 849 MHz	890 – 915 MHz	824 – 849 MHz
<b>Frekuensi Downlink</b>	869 – 894 MHz	935 – 960 MHz	869 – 894 MHz

# History

## ❑ Generasi pertama (1G)

Sistem komunikasi seluler pertama kali beroperasi di norwegia pada tahun 1981 dan diikuti oleh sistem yang sama di US dan UK. System generasi pertama ini hanya mentransmisikan voice dengan frekuensi sekitar 900 MHz dan menggunakan modulasi analog

## ❑ Generasi kedua (2G)

GSM (Global System for Mobile Communications) pertama kali digunakan di eropa pada awal tahun 1990. GSM menyediakan layanan voice dan data yang terbatas. Menggunakan modulasi digital.

## ❑ The new third generation (3G) cellular services

Universal Mobile Telecommunications System (UMTS) or IMT-2000 will sustain higher data rates still and opens the door to many internet style applications

# History

- ▶ 1934–USA : AM based: First generation Analogue Cellular Systems
  - For public safety
  - 5000 mobiles
  - Vehicle ignition noise a major problem
- ▶ 1935 USA Europe Asia :FM based:
  - Frequency bands: – 800 – 900 MHz and 400 – 500 MHz
  - 120 kHz RF bandwidth with channel spacing of 30 kHz
  - Data rate 5 – 10 kbps
  - No of channels 400 – 1000, half-duplex
- ▶ 1946– USA : First Generation Public Mobile Telephone Service:
  - Coverage distance: 50 km, 60 kHz bandwidth
  - Single powerful transmitter

# Perkembangan sistem telepon bergerak

<b>Tahun</b>	<b>Mobile System</b>
1981	Nordic Mobile Telephone (NMT) 450
1983	American Mobile Phone System (AMPS)
1985	Total Access Communication System (TACS)
1986	Nordic Mobile Telephony (NMT) 900
1991	American Digital Cellular (ADC)
1991	Global System for Mobile Communication (GSM)
1992	Digital Cellular System (DCS) 1800
1994	Personal Digital Cellular (PDC)
1995	PCS 1900—Canada
1996	PCS—United States

# Perkembangan Teknologi Cellular

	AMPS	GSM	IS-95
Akses jamak	FDMA	TDMA	CDMA
Modulasi	FM	GMSK	QPSK
Bandwidth RF	30 kHz	200 kHz	1,25 MHz
Kanal / carrier RF	1	8	20 - 30
Uplink (MHz)	824-849	890-915	824-849
Downlink (MHz)	869-894	935-960	869-894

# History – 1st Generation (1G) Systems

- ▶ 1960 Cellular Radio, developed by Bell Labs.
- ▶ 1970 Cellular Mobile System (USA)
- ▶ **1980 First Generation Analogue Cellular Systems**
  - Advanced Mobile Telephone Systems (AMPS)
  - Frequency bands: 800 – 900 MHz and 400 – 500 MHz
  - Channel spacing 30 kHz and no of channels 400 – 1000
  - Data rate 5 – 10 kbps
  - FM for speech, FSK for signaling, FDM

# Block diagram of the first generation cellular network.

- ▶ All first generation cellular networks are based on analog technology and use FM modulation. An example of the first generation cellular telephone system is Advanced Mobile Phone Services (AMPS)

## AMPS

- Pioneer of cellular telecommunications
- FDMA-based analog system
  - Low capacity of subscriber per cell
- Unsecure
  - Phone number can be scanned and copied
  - Voice conversation is not encrypted

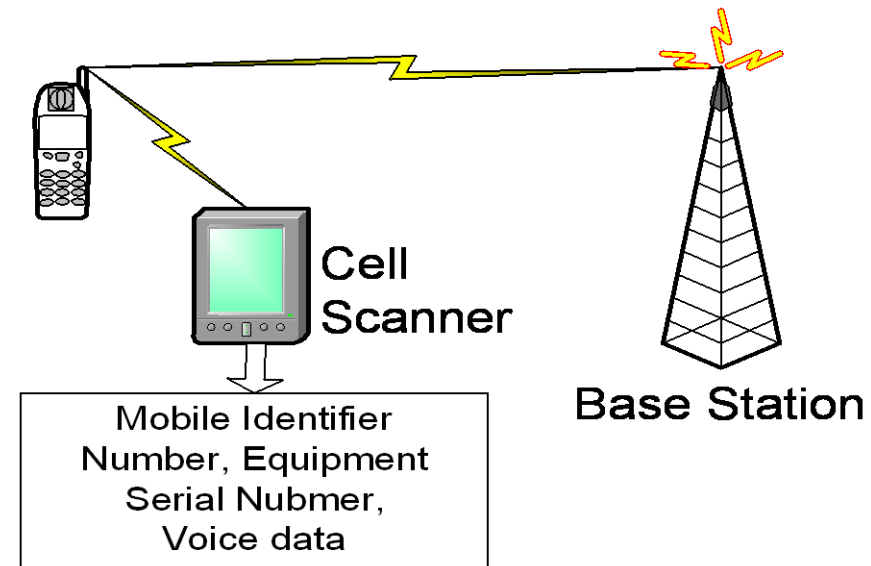

# AMPS-DAMPS=North American Digital Cellular (NADC) Comparison

	Analog	Digital
standard	EIA-553 (AMPS)	IS-54 (TDMA + AMPS)
spectrum	824 MHz to 891 MHz	824 MHz to 891 MHz
channel bandwidth	30 kHz	30 kHz
channels	21 CC/395 VC	21 CC / 395 VC
conversations per channel	1	3 or 6
subscriber capacity	40 to 50 conversations per cell	125 to 300 conversations per cell
TX/RCV type	continuous	time shared bursts
carrier type	constant phase variable frequency	constant frequency variable phase
mobile/base relationship	mobile slaved to base	authority shared cooperatively
privacy	poor	better—easily scrambled
noise immunity	poor	high
fraud detection	ESN plus optional password (PIN)	ESN plus optional password (PIN)



# Keterbatasan AMPS

- low calling capacity
- limited spectrum
- no room for spectrum growth
- poor data communications
- minimal privacy
- inadequate fraud protection

# History – 2nd Generation (2G) System (1991–2)

## ▶ **Systems:**

- Group Special Mobile (GSM) – Europe (GSM 1.8 GHz, and 1.9 GHz)
- U.S. Digital Cellular (USDC) and CDMA (USDC 1.9 GHz)
- Digital Cordless Systems (DCS) 1.8 GHz

## ▶ **Technology:** TDMA, TDMA hybrid FDMA

## ▶ **Characteristics:**

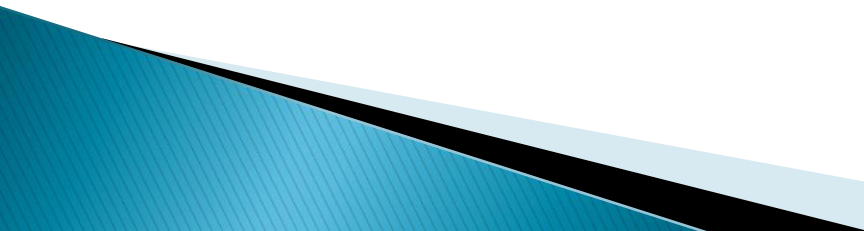
- Digital voice and low speed data
  - Frequency band @ 900 MHz, RF channel spacing 200 kHz
  - Modulation: GMSK, DPSK, Fixed frequency assignment
  - Speech rate 13 kbps, Speech coding, TDMA
  - High security and higher capacity,
  - Improved speech Quality of service (QoS)
- 

# GSM Milestone

<b>Tahun</b>	<b>Milestone</b>
1982	GSM formed
1986	field test
1987	TDMA chosen as access method
1988	memorandum of understanding signed
1989	validation of GSM system
1990	preoperation system
1991	commercial system start-up
1992	coverage of larger cities/airports
1993	coverage of main roads
1995	coverage of rural areas

# Second Generation Wireless Networks

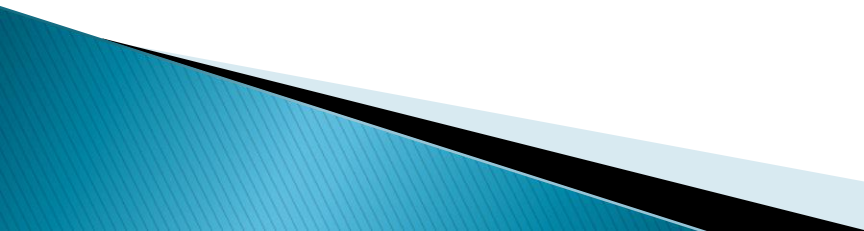
- ▶ Second generation wireless systems employ digital modulation and advanced call processing capabilities.
  - ▶ Examples of second generation wireless systems include the :
    - Global System for Mobile (GSM),
    - the IS-54 TDMA and
    - the IS-95 CDMA TIA digital standards.
- 

# Sistem Seluler Digital

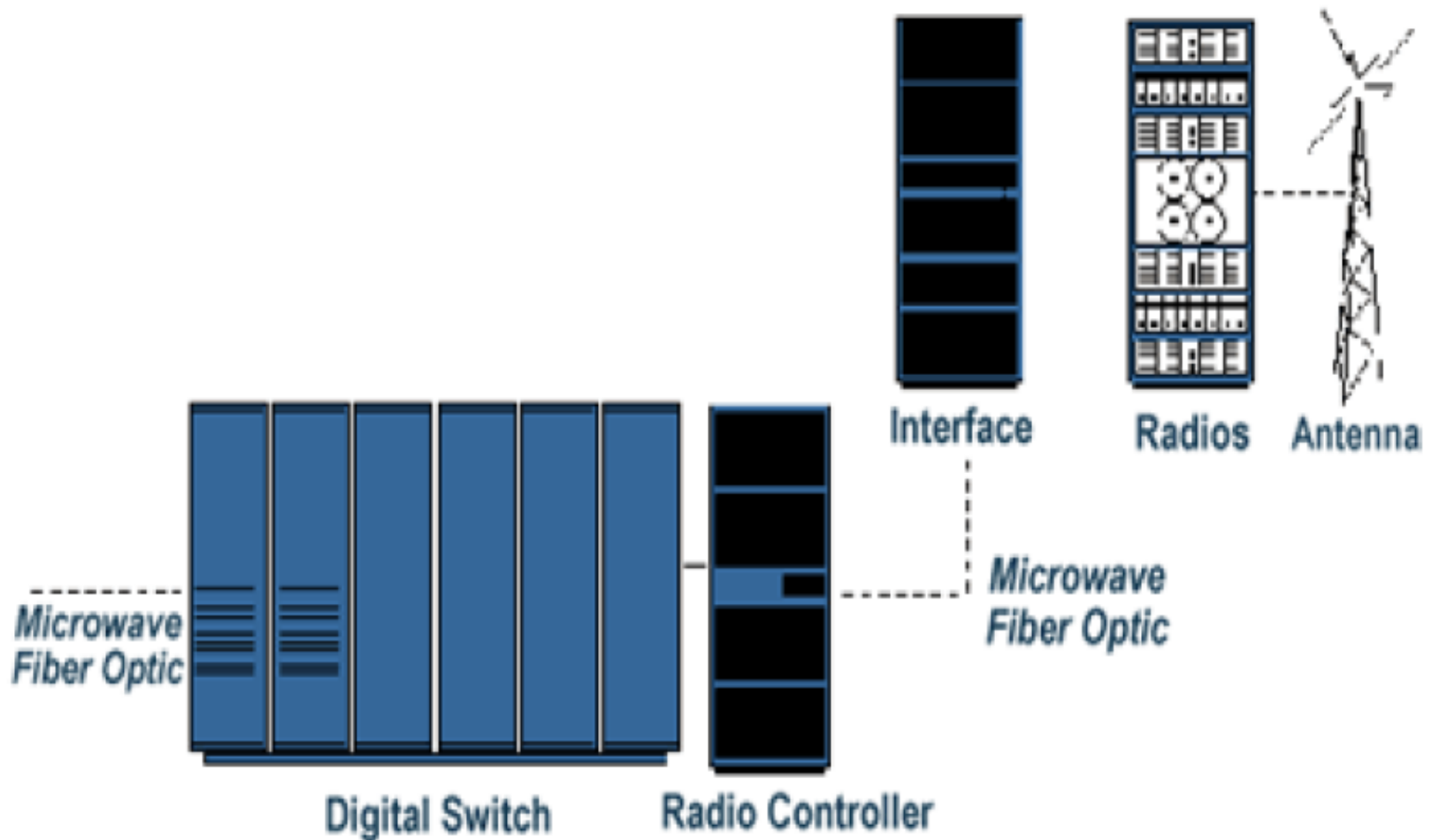

# Global System for Mobile Communications.

- Beroperasi pada band frekuensi 900, 1800 atau 1,900 MHz .
- Teknologi seluler paling populer hampir di seluruh negara-negara di dunia
- TDMA-based digital system
  - 8 kali kapasitas AMPS per frequency band
- Secure
  - Seluruh informasi yang dipertukarkan antara Mobile Station (MS) dan Base Station (BS) dienkripsi

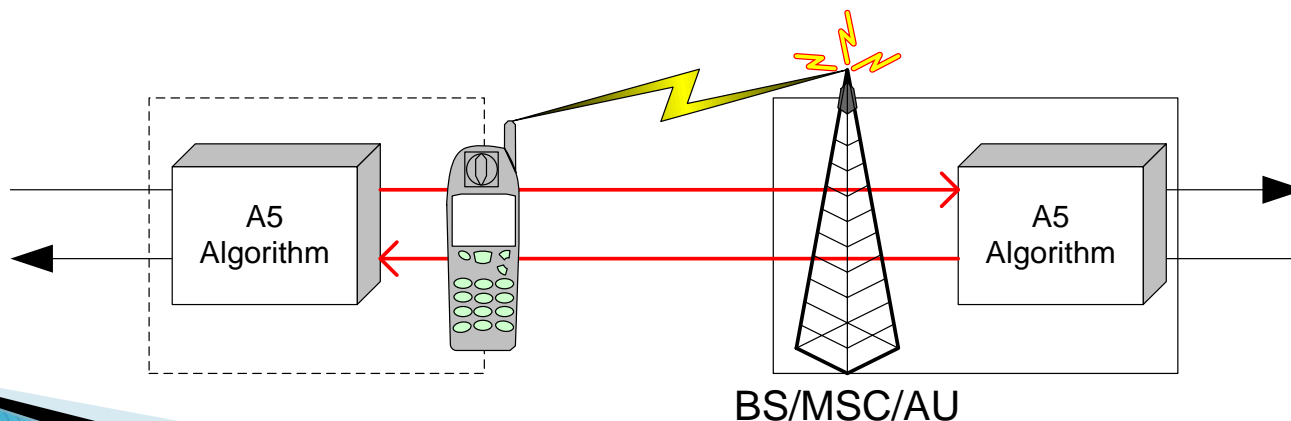

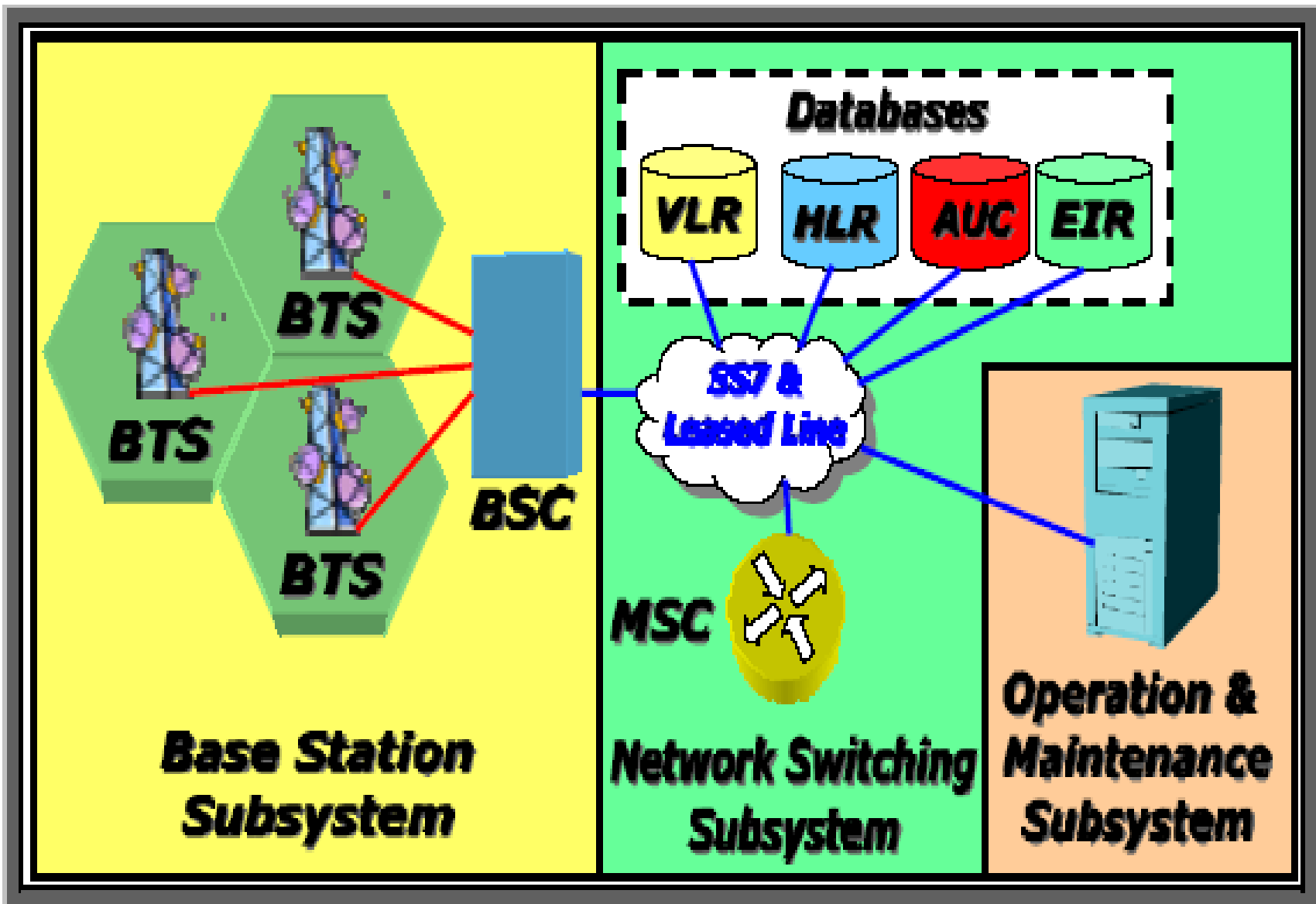

Figure 9 Typical GSM PLMN<sup>27 28</sup>

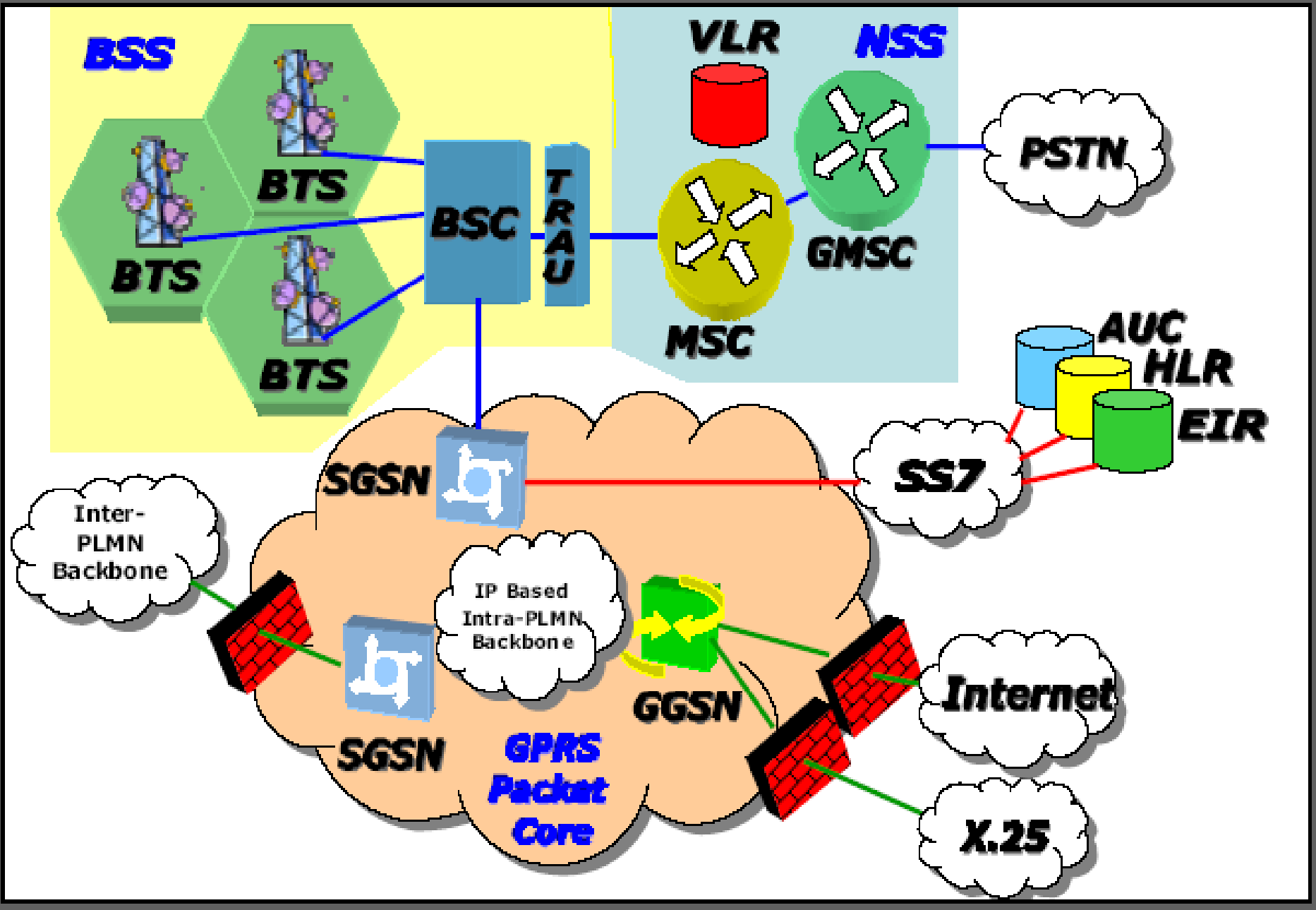
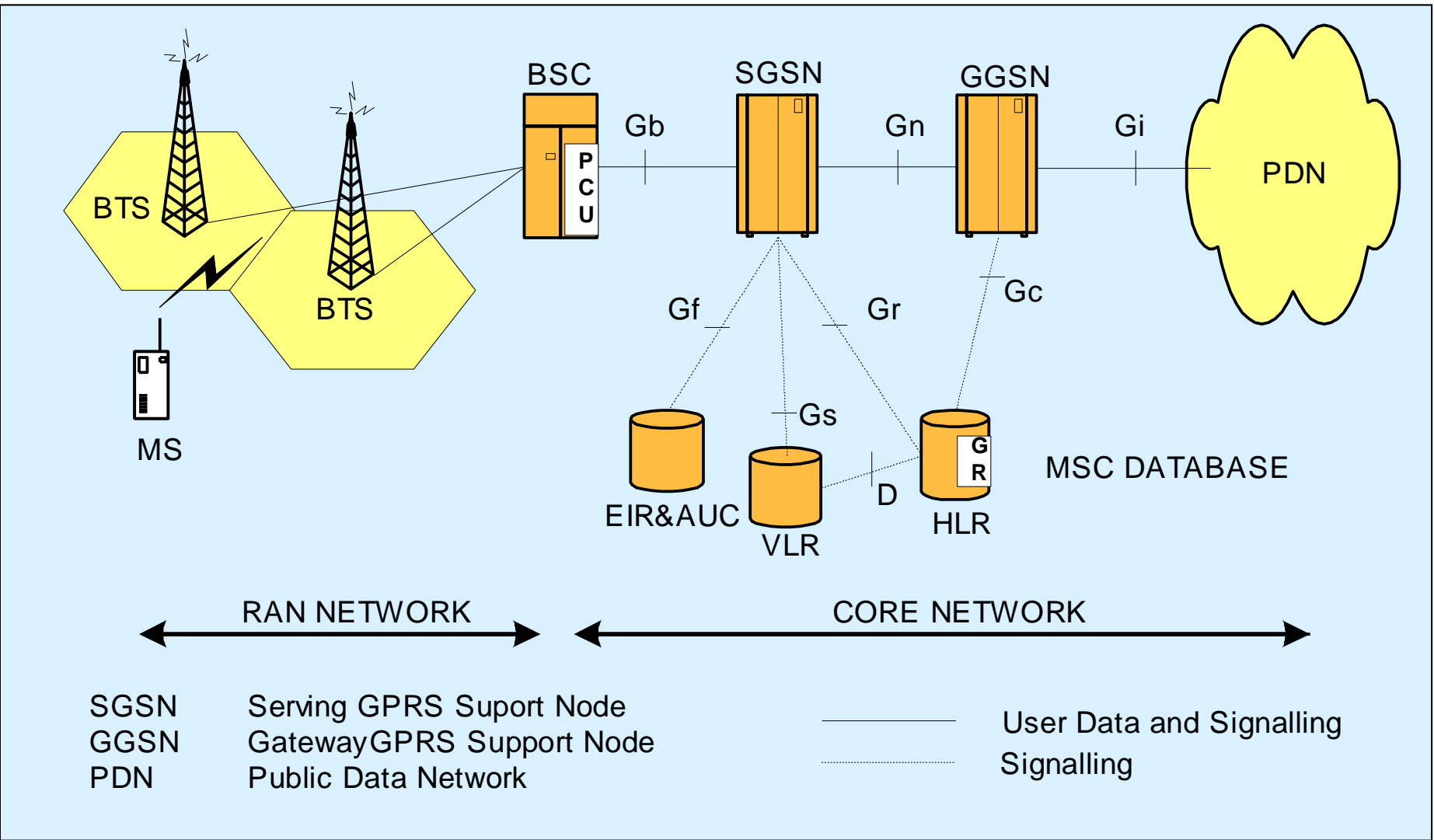

Figure 12 Typical GPRS Network<sup>52 53</sup>



# Arsitektur Dasar Jaringan GPRS dalam GSM



# History – 3rd Generation (3G) Systems (1995 – )

- ▶ Support Multimedia Services:
  - Especially Internet Service,
  - 144kb/s (Outdoor and higher velocity ),
  - 384kb/s(from outdoor to indoor),
  - 2Mb/s (indoor);
  - Speech of QoS and other services
- ▶ First Transitional System: 2 GHz
- ▶ 2000 – 2nd Transitional Systems: 2.5 GHz
- ▶ 2001 – 1st CDMA Network @ 144 k bps
- ▶ 2002– Handover between GSM and WCDMA

# CDMA2000 Milestones (1)

- 11/89 : First demonstration of CDMA (San Diego)
- 1993 : IS-95A standard complete
- 09/95 : Commercial launch of IS-95A in Hongkong (Hutchison Telecom)**
- 1996 : Commercial Launch of IS95-A in South Korea (SK Telecom)**
- 05/97 : First IS-95A WLL launch (MTNL, India)
- 06/97 : IS-95B standard complete; includes 64 kbps data
- 06/97 : cdmaOne brand name launched by CDG for IS-95 CDMA
- 12/97 : 7.8 million CDMA subscribers worldwide
- 03/98 : LG Telecom (Korea) launches first CDMA data services
- 06/98 : CDMA2000 submitted to ITU for IMT-2000
- 12/98 : 23 million CDMA subscribers worldwide
- 03/00 : First CDMA2000 1X voice calls successfully completed**
- 04/00 : Bell Mobility, Nortel Networks, QUALCOMM, Samsung and Sprint PCS successfully complete a series of 3G wireless calls using CDMA2000 1X technology
- 06/00 : CDMA2000 1xEV introduced to global marketplace by the CDG**
- 10/00 : First ever CDMA-GSM interoperable SIM card introduced to the global market

# CDMA2000 Milestones (2)

- 10/00 : SK Telecom and LG Telecom (Korea) launch world's first 3G commercial services using CDM2000**
- 12/00 : 80.4 million CDMA subscribers worldwide
- 03/01 : CDMA2000 1xEV-DV successfully demonstrated in labs
- 06/01 : CDMA2000 1xEV-DO recognized as part of the 3G IMT-2000 standard
- 08/01 : 1 million commercial CDMA2000 1X subscribers
- 12/01 : 111 million CDMA subscribers worldwide
- 01/02 : SK Telecom (Korea) launches world's first CDMA2000 1xEV-DO**
- 05/02 : 10 million commercial CDMA2000 1X subscribers
- 06/02 : **CDMA2000 1xEV-DV (Data Voice) approved** by both the Third Generation Partnership Project 2 (3GPP2) and Telecommunications Industry Association (TIA) for publication
- 08/02 : Ericsson, LG Electronics, Lucent Technologies, Motorola, Nortel Networks, Qualcomm, Samsung and ZTE sign Memorandum of Understanding to commercially deliver CDMA2000 infrastructure and terminals for 2.1 GHZ

# Third Generation Wireless Networks

- ▶ The aim of third generation wireless networks is to provide a single system that can meet a wide range of applications and provide universal access.
- ▶ The third generation networks will carry many types of information such as voice , data and video and serve both stationary and fixed users.
- ▶ Some of the systems proposed for the third generation systems are
  - CDMA2000 which is backward compatible to systems based on IS 95 and
  - WCDMA which is backward compatible to GSM systems.

# Evolusi Teknologi CDMA

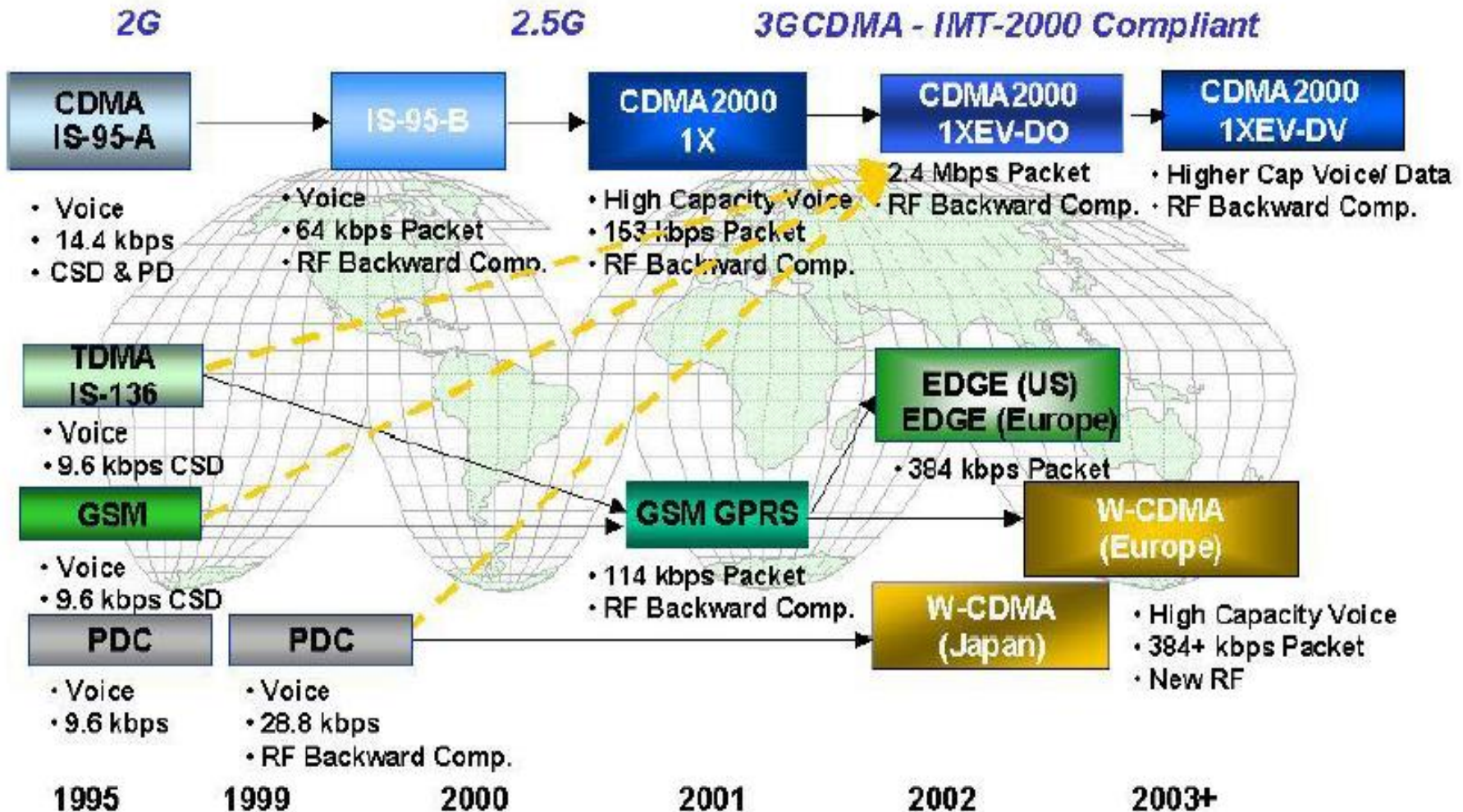

# Evolusi Layanan CDMA

CDMA enables the kind of capabilities needed to realize significant advancements in services (cont.)

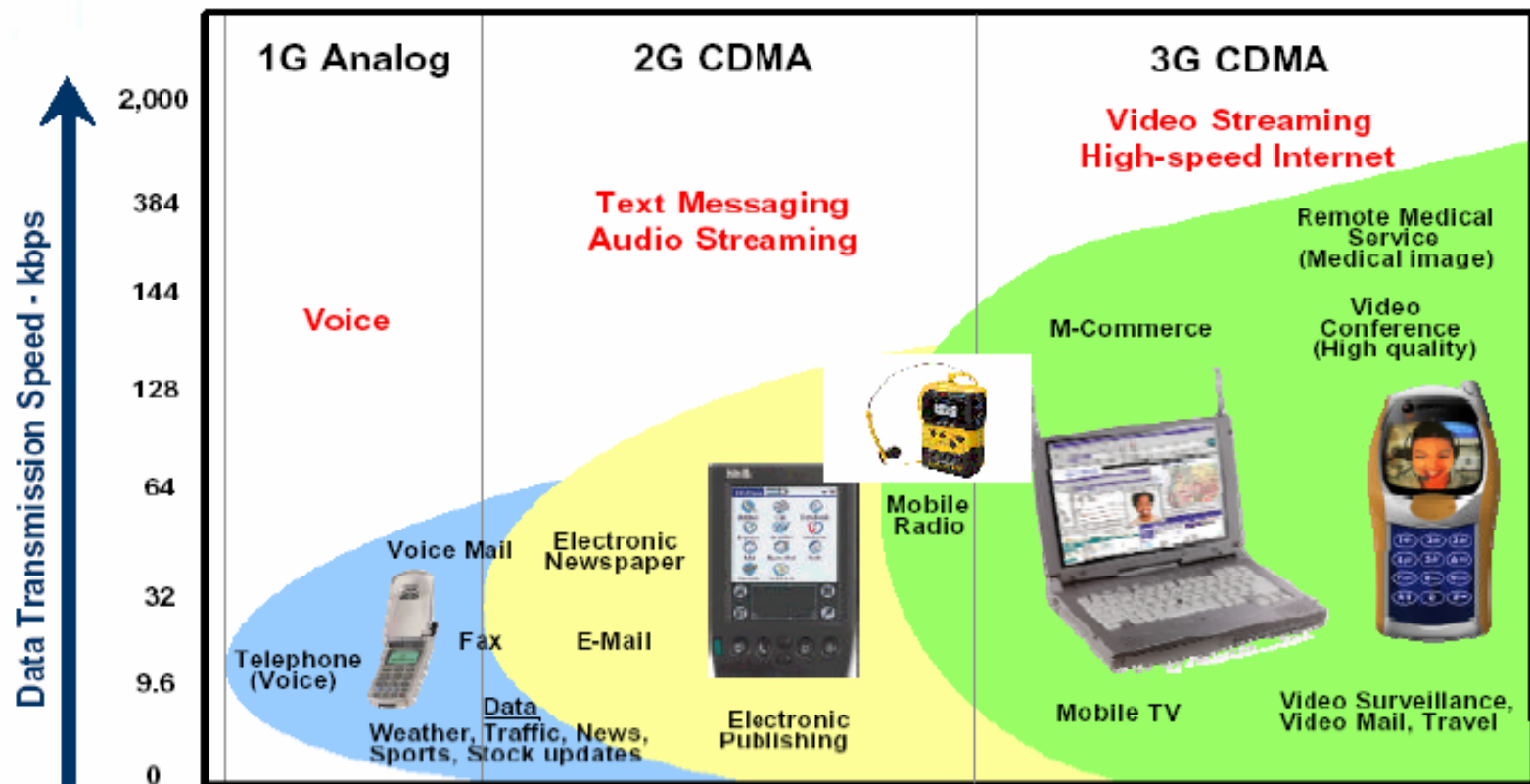



UMTS technology delivers high-speed access to information, email, multimedia content, as well as other wireless Internet services through a variety of personal, portable devices

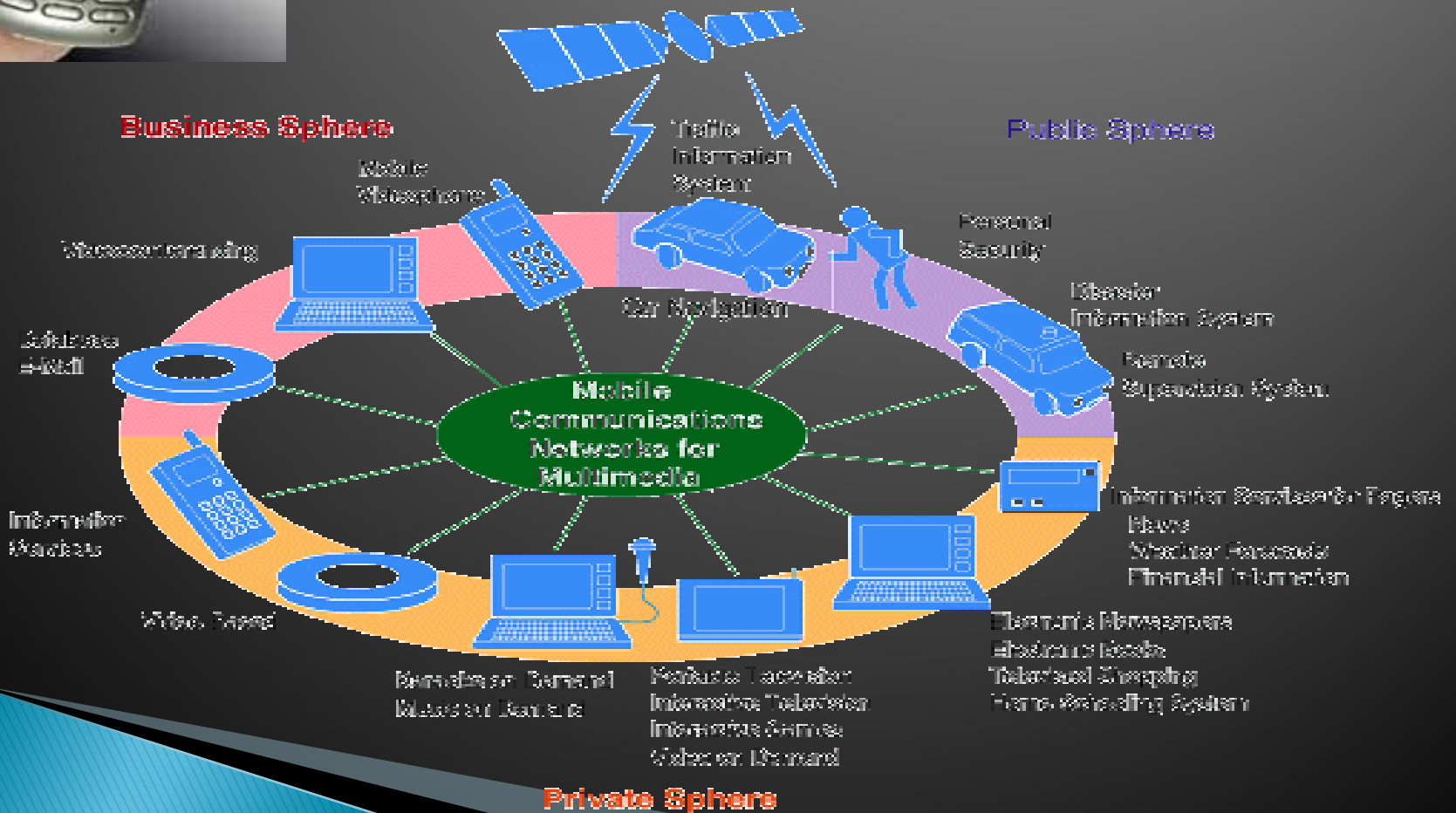



# Fixed Wireless Access

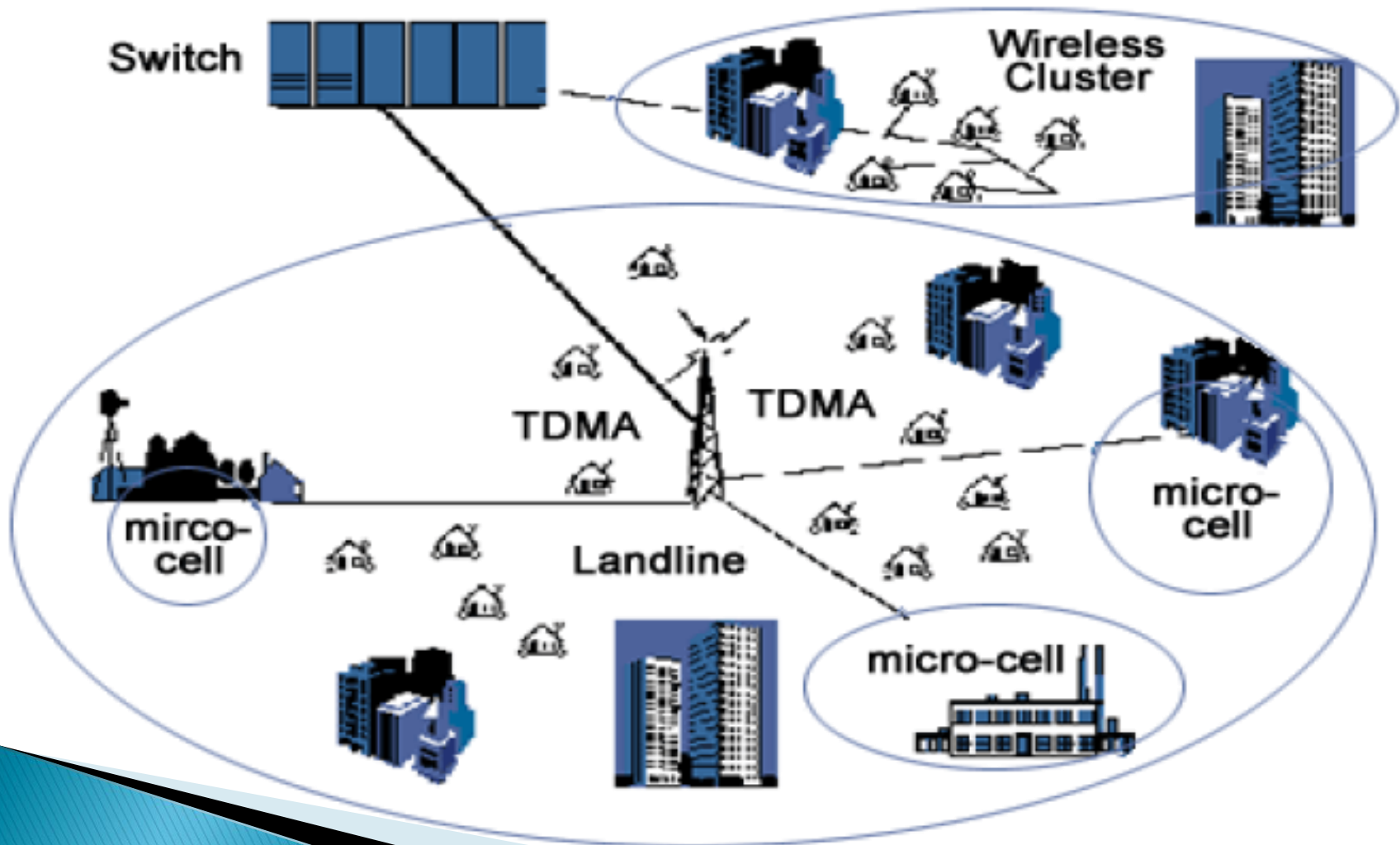

# BROADBAND WIRELESS ACCESS – TOTAL SOLUTION

## TOTAL SOLUTION WiMAX

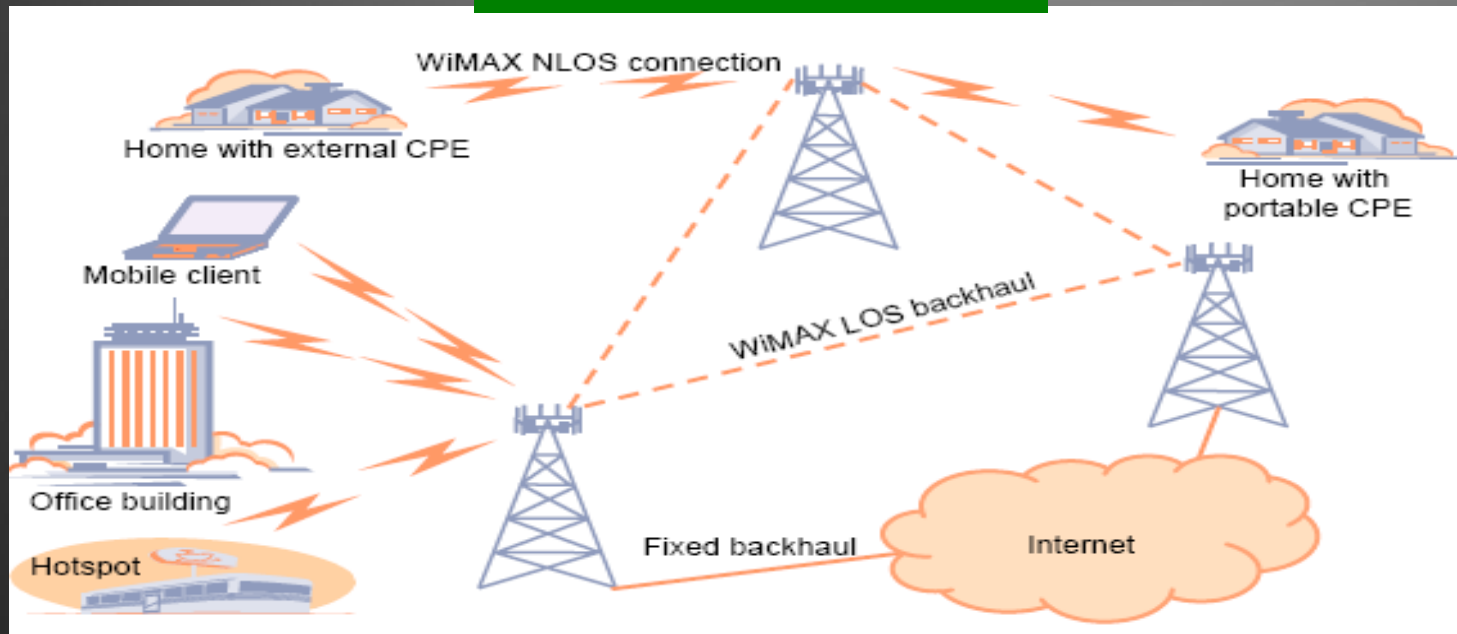

- **SOLUSI TOTAL BWA – WiMAX**  
pemanfaatan untuk memenuhi demand dan pembangunan jaringan komunikasi broadband di area-area baru maupun area yang sulit untuk dijangkau (special terrain) seperti di area rural, pegunungan, perkebunan, pertambangan, offshore dll.
- **PENGEMBANGAN BWA - WiMAX “Hot Zone”**  
untuk perluasan coverage dari “Hotspot” ke dense area (outdoor) sebagai dukungan layanan WiFi Hotspot dan mengcover komunikasi di area blank spot Hotspot.

**Selesai .....**

Terima Kasih